

Protocol Operation

Modbus® Communications Protocol

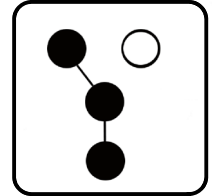
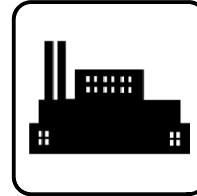
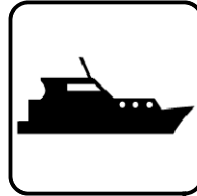

Models:

Generator Set Controllers:

Decision-Maker® 3+, 340, 550, 3000, 3500, and 6000

Transfer Switch Controllers:

M340/M340+, MPAC™ 1000 and MPAC™ 1500

Power Monitor:

PM340

KOHLER®
Power Systems

ISO 9001
KOHLER
POWER SYSTEMS
NATIONALLY REGISTERED

TP-6113 9/14h

Table of Contents

Safety Precautions and Instructions	5
Introduction	7
Modbus Protocol	7
List of Related Materials	7
Service Assistance	8
Section 1 Configurations and Definitions	9
1.1 Network Configurations	9
1.2 Serial Settings	10
1.3 Modbus Protocol Definitions	10
1.4 Modbus Functions and Exception Codes	12
Section 2 Decision-Maker 3+ Controller with Communications	13
2.1 Introduction	13
2.2 Communication Board Identification	14
2.3 Controller Connection and Setup	14
2.3.1 Network Connection	15
2.3.2 Controller Setup	15
2.4 Modbus Registers and Codes	16
2.4.1 Modbus Registers	16
2.4.2 Shutdown Fault Codes	17
2.4.3 MDEC/ADEC Fault Codes	17
2.4.4 Flags/Warnings	18
Section 3 Decision-Maker 340 Generator Set Controller	19
3.1 Introduction	19
3.2 Hardware and Connections	19
3.3 Controller Setup	20
3.4 Modbus Registers	21
3.5 Alert Codes	24
Section 4 Decision-Maker 550 Generator Set Controller	25
4.1 Specifications	25
4.2 Hardware Connections	25
4.3 Controller Setup	27
4.4 Controller Application Code Versions	27
4.5 Modbus Maps for Controllers with Application Code Versions 2.10 or Higher ...	28
4.5.1 Guide to the Register Map	28
4.5.2 Modbus Registers	29
4.5.3 Remapped Registers	40
4.5.4 Relay Driver Outputs	41
4.5.5 System Event Codes	41
4.5.6 System Event Code Table	42
4.5.7 Digital Auxiliary Input Functions	44
Section 5 Decision-Maker 3000 Generator Set Controller	45
5.1 Specifications	45
5.2 Hardware Connections	45
5.3 Controller Setup	46
5.4 Modbus Registers	47
5.5 Inputs and Outputs	53
5.6 Event Codes	56
Section 6 Decision-Maker 3500 Generator Set Controller	61
6.1 Specifications	61
6.2 Hardware Connections	61
6.3 Controller Setup	62
6.4 Modbus Registers	63
6.5 Inputs and Outputs Events	75

Table of Contents, continued

6.6	Failure Mode Indicator (FMI)	77
6.7	Severity Level	77
6.8	Object ID	77
6.9	Event ID 1	78
Section 7	Decision-Maker 6000 Generator Set Controller	81
7.1	Specifications	81
7.2	Hardware Connections	81
7.3	Controller Setup	83
7.4	Modbus Registers	84
7.4.1	Guide to the Register Map	84
7.4.2	Modbus Registers	85
7.4.3	Remapped Registers	98
7.4.4	Relay Driver Outputs	99
7.4.5	System Event Codes	99
7.4.6	System Event Code Table	100
7.4.7	Digital Auxiliary Input Functions	102
Section 8	M340 and M340+ ATS Controllers	103
8.1	Introduction	103
8.2	Hardware and Connections	103
8.3	Controller Setup	104
8.4	Modbus Registers	105
8.5	M340/M340+ Alert Codes	108
Section 9	MPAC 1000 ATS Controller	109
9.1	Specifications	109
9.2	Hardware Connections	109
9.3	Controller Setup	110
9.4	Modbus Registers	111
9.4.1	Guide to the Register Map	111
9.4.2	Modbus Registers	111
9.4.3	Event Codes	118
Section 10	MPAC 1500 ATS Controller	121
10.1	Specifications	121
10.2	Hardware Connections	121
10.3	Controller Setup	123
10.4	Modbus Registers	124
10.4.1	Guide to the Register Map	124
10.4.2	Passwords	124
10.4.3	Modbus Registers	125
10.4.4	Event Codes	139
Section 11	Power Monitor	141
11.1	Introduction	141
11.2	Hardware and Connections	141
11.3	Device Setup	142
11.4	Power Monitor Modbus Registers	143
11.5	Alert Codes	144
Appendix A	Abbreviations	145
Appendix B	Noise and Wiring Practices	147
Appendix C	Decision-Maker 550 Controllers, Versions Below 2.10	148
	Guide to Register Map	148
	Modbus Registers	149
	Message Codes: Event History, Common Fault, and RDO Byte Summary	157
	Function Codes: Digital Auxiliary Input	158

Safety Precautions and Instructions

IMPORTANT SAFETY INSTRUCTIONS. Electromechanical equipment, including generator sets, transfer switches, switchgear, and accessories, can cause bodily harm and pose life-threatening danger when improperly installed, operated, or maintained. To prevent accidents be aware of potential dangers and act safely. Read and follow all safety precautions and instructions. **SAVE THESE INSTRUCTIONS.**

This manual has several types of safety precautions and instructions: Danger, Warning, Caution, and Notice.

DANGER

Danger indicates the presence of a hazard that **will cause severe personal injury, death, or substantial property damage.**

WARNING

Warning indicates the presence of a hazard that **can cause severe personal injury, death, or substantial property damage.**

CAUTION

Caution indicates the presence of a hazard that **will or can cause minor personal injury or property damage.**

NOTICE

Notice communicates installation, operation, or maintenance information that is safety related but not hazard related.

Safety decals affixed to the equipment in prominent places alert the operator or service technician to potential hazards and explain how to act safely. The decals are shown throughout this publication to improve operator recognition. Replace missing or damaged decals.

Accidental Starting

WARNING

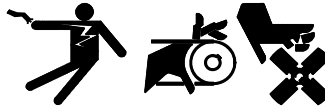

Accidental starting.
Can cause severe injury or death.

Disconnect the battery cables before working on the generator set. Remove the negative (-) lead first when disconnecting the battery. Reconnect the negative (-) lead last when reconnecting the battery.

Disabling the generator set. Accidental starting can cause severe injury or death. Before working on the generator set or connected equipment, disable the generator set as follows: (1) Move the generator set master switch to the OFF position. (2) Disconnect the power to the battery charger. (3) Remove the battery cables, negative (-) lead first. Reconnect the negative (-) lead last when reconnecting the battery. Follow these precautions to prevent starting of the generator set by an automatic transfer switch, remote start/stop switch, or engine start command from a remote computer.

Disabling the generator set. Accidental starting can cause severe injury or death. Before working on the generator set or equipment connected to the set, disable the generator set as follows: (1) Press the generator set off/reset button to shut down the generator set. (2) Disconnect the power to the battery charger, if equipped. (3) Remove the battery cables, negative (-) lead first. Reconnect the negative (-) lead last when reconnecting the battery. Follow these precautions to prevent the starting of the generator set by the remote start/stop switch.

Hazardous Voltage/ Moving Parts

DANGER



Hazardous voltage.
Will cause severe injury or death.

Disconnect all power sources before opening the enclosure.

DANGER



Hazardous voltage.
Will cause severe injury or death.

Only authorized personnel should open the enclosure.

Grounding electrical equipment. Hazardous voltage can cause severe injury or death. Electrocutation is possible whenever electricity is present. Ensure you comply with all applicable codes and standards. Electrically ground the generator set, transfer switch, and related equipment and electrical circuits. Turn off the main circuit breakers of all power sources before servicing the equipment. Never contact electrical leads or appliances when standing in water or on wet ground because these conditions increase the risk of electrocution.

Servicing the transfer switch. Hazardous voltage can cause severe injury or death. Deenergize all power sources before servicing. Turn off the main circuit breakers of all transfer switch power sources and disable all generator sets as follows: (1) Move all generator set master controller switches to the OFF position. (2) Disconnect power to all battery chargers. (3) Disconnect all battery cables, negative (-) leads first. Reconnect negative (-) leads last when reconnecting the battery cables after servicing. Follow these precautions to prevent the starting of generator sets by an automatic transfer switch, remote start/stop switch, or engine start command from a remote computer. Before servicing any components inside the enclosure: (1) Remove all jewelry. (2) Stand on a dry, approved electrically insulated mat. (3) Test circuits with a voltmeter to verify that they are deenergized.

Making line or auxiliary connections. Hazardous voltage can cause severe injury or death. To prevent electrical shock deenergize the normal power source before making any line or auxiliary connections.

Short circuits. Hazardous voltage/current can cause severe injury or death. Short circuits can cause bodily injury and/or equipment damage. Do not contact electrical connections with tools or jewelry while making adjustments or repairs. Remove all jewelry before servicing the equipment.

Notice

NOTICE

Electrostatic discharge damage. Electrostatic discharge (ESD) damages electronic circuit boards. Prevent electrostatic discharge damage by wearing an approved grounding wrist strap when handling electronic circuit boards or integrated circuits. An approved grounding wrist strap provides a high resistance (about 1 megohm), *not a direct short*, to ground.

This manual provides instructions for using the Modbus® RTU communication protocol with the following Kohler® controllers:

- Decision-Maker® 3+ generator set controller with communications
- Decision-Maker® 340 generator set controller *
- Decision-Maker® 550 generator set controller
- Decision-Maker® 3000 generator set controller
- Decision-Maker® 3500 generator set controller
- Decision-Maker® 6000 paralleling generator set controller
- M340/M340+ ATS controller *
- MPAC™ 1000 ATS controller
- MPAC™ 1500 ATS controller
- PM340Power Monitor *

* Device must be equipped with Modbus/KBUS converter kit GM41143-KP3 for Modbus communication.

Information in this publication represents data available at the time of print. Kohler Co. reserves the right to change this literature and the products represented without notice and without any obligation or liability whatsoever.

Read this manual and carefully follow all procedures and safety precautions to ensure proper equipment operation and to avoid bodily injury. Read and follow the Safety Precautions and Instructions section at the beginning of this manual.

Modbus Protocol

The Modbus® protocol, initially developed by the Modicon Corporation, is a de facto industry communication standard used by a controller to communicate with other devices. A complete discussion of the protocol is beyond the scope of these instructions. See the applicable Modbus® master application program documentation or other reliable technical information sources for Modbus® protocol details.

This manual contains:

- Modbus® connection information
- Controller setup instructions
- Modbus® register documentation

The system designer assumes responsibility for ensuring that the equipment is used only as intended by the manufacturer. Always conduct a full test and debug of the programming software prior to installing and using

it in the system. The manufacturer disclaims any and all responsibility for use of third-party application software that will be used to control the equipment.

List of Related Materials

The protocol covered in this manual is part of a total control system. The controller operation manual provides information about setting up the controller to enable remote communications and programming. It also provides information about equipment operating limits, specifications, and functions. See Figure 1 for document part numbers.

Consult the specification sheets, accessory installation instructions, service bulletins, application notes, drawings, and other applicable literature for additional information on equipment operating limits and specifications. Contact your local distributor/dealer or the equipment manufacturer to obtain applicable literature.

Operation Manual for Model:	Part Number
Decision-Maker® 3+ Controller	TP-6161
Decision-Maker® 340 Controller	TP-5829
Decision-Maker® 550 Controller: Version 2.10 and higher	TP-6200
Versions prior to 2.10	TP-6083
Controller Setup and Application	TP-6140
Decision-Maker® 3000 Controller	TP-6694
Decision-Maker® 3500 Marine Controller	TP-6861
Decision-Maker® 6000 Controller	TP-6750
Automatic Transfer Switches with MPAC™ 1500 Controls:	
MPAC™ 1500 Version 2.00 and higher	TP-6714
Model KCS, KCP	TP-6446
Model KSS, KSP	TP-6447
Model KBS, KBP Bypass/Isolation	TP-6448
Model KGS, KGP Bypass/Isolation	TP-6449
Automatic Transfer Switches with MPAC™ 1000 Controls:	
Model KCT, KCP	TP-6126
Model KBT, KBP Bypass/Isolation	TP-6128
Model KDT, KDP	TP-6225
M340+ Transfer Switch Controller	TP-5664
PM340 power monitor	TP-5875
Installation Instructions, Connection and Converter Kits	TT-1405
Communication Module for the Decision-Maker™ 3+ Generator Set Controller	TT-1377

Figure 1 List of Related Materials

Modbus® is a registered trademark of Schneider Electric.

Service Assistance

For professional advice on generator set power requirements and conscientious service, please contact your nearest Kohler distributor or dealer.

- Consult the Yellow Pages under the heading Generators—Electric.
- Visit the Kohler Power Systems website at KOHLERPower.com.
- Look at the labels and stickers on your Kohler product or review the appropriate literature or documents included with the product.
- Call toll free in the US and Canada 1-800-544-2444.
- Outside the US and Canada, call the nearest regional office.

Headquarters Europe, Middle East, Africa (EMEA)

Kohler Power Systems Netherlands B.V.
Kristallaan 1
4761 ZC Zevenbergen
The Netherlands
Phone: (31) 168 331630
Fax: (31) 168 331631

Asia Pacific

Power Systems Asia Pacific Regional Office
Singapore, Republic of Singapore
Phone: (65) 6264-6422
Fax: (65) 6264-6455

China

North China Regional Office, Beijing
Phone: (86) 10 6518 7950
(86) 10 6518 7951
(86) 10 6518 7952
Fax: (86) 10 6518 7955

East China Regional Office, Shanghai
Phone: (86) 21 6288 0500
Fax: (86) 21 6288 0550

India, Bangladesh, Sri Lanka

India Regional Office
Bangalore, India
Phone: (91) 80 3366208
(91) 80 3366231
Fax: (91) 80 3315972

Japan, Korea

North Asia Regional Office
Tokyo, Japan
Phone: (813) 3440-4515
Fax: (813) 3440-2727

Latin America

Latin America Regional Office
Lakeland, Florida, USA
Phone: (863) 619-7568
Fax: (863) 701-7131

Section 1 Configurations and Definitions

1.1 Network Configurations

A controller can communicate directly to a Modbus® master or participate in a network of devices. It can also be used to interface a local master to a network of devices.

The Modbus® master polls slave devices for data. Controller devices are slaves. Examples of master devices are a personal computer running Monitor III software (or other Modbus driver) and the RSA 1000 remote serial annunciator.

In an RS-485 network, there can be only one master device. See Figure 1-1 through Figure 1-4 for an overview of the possible configurations. The configuration chosen determines required connections and the controller setup.

A Modbus/Ethernet converter can be used to connect a controller or multiple controllers connected in an RS-485 network to the ethernet. See Figure 1-5. One or more Modbus masters can then communicate with the devices over the Ethernet.

The MPAC™ 1500 transfer switch controller does not require a Modbus/Ethernet converter.

The 550 controller can use either RS-232 or RS-485 connections, and can function as an RS-232 to RS-485 converter. Other controllers covered in this manual use RS-485 connections. All devices in a network must use the same baud rate.

Note: Install communication conductors in raceways, cables, or conduit separate from AC power conductors.

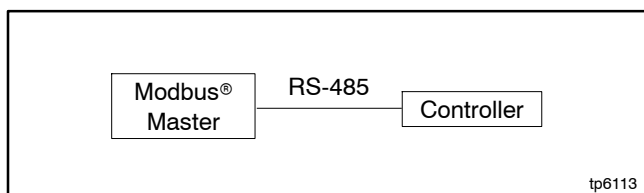

Figure 1-1 Single RS-485 Connection

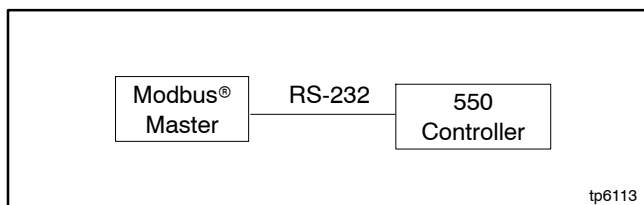

Figure 1-2 Single RS-232 Connection, 550 Controller

Modbus® is a registered trademark of Schneider Electric.

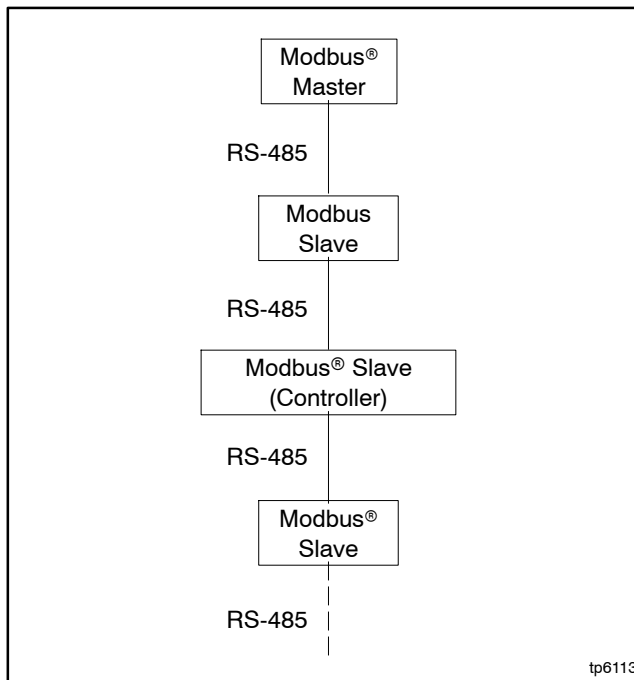

Figure 1-3 RS-485 Network

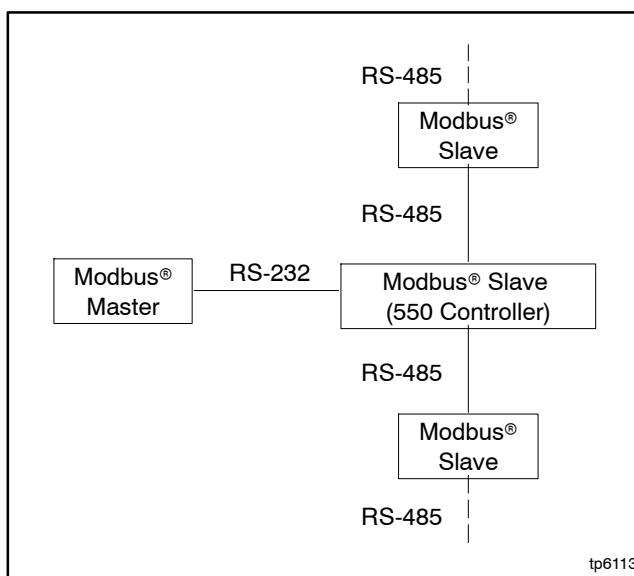

Figure 1-4 RS-485 Network with the 550 Controller used as a Converter

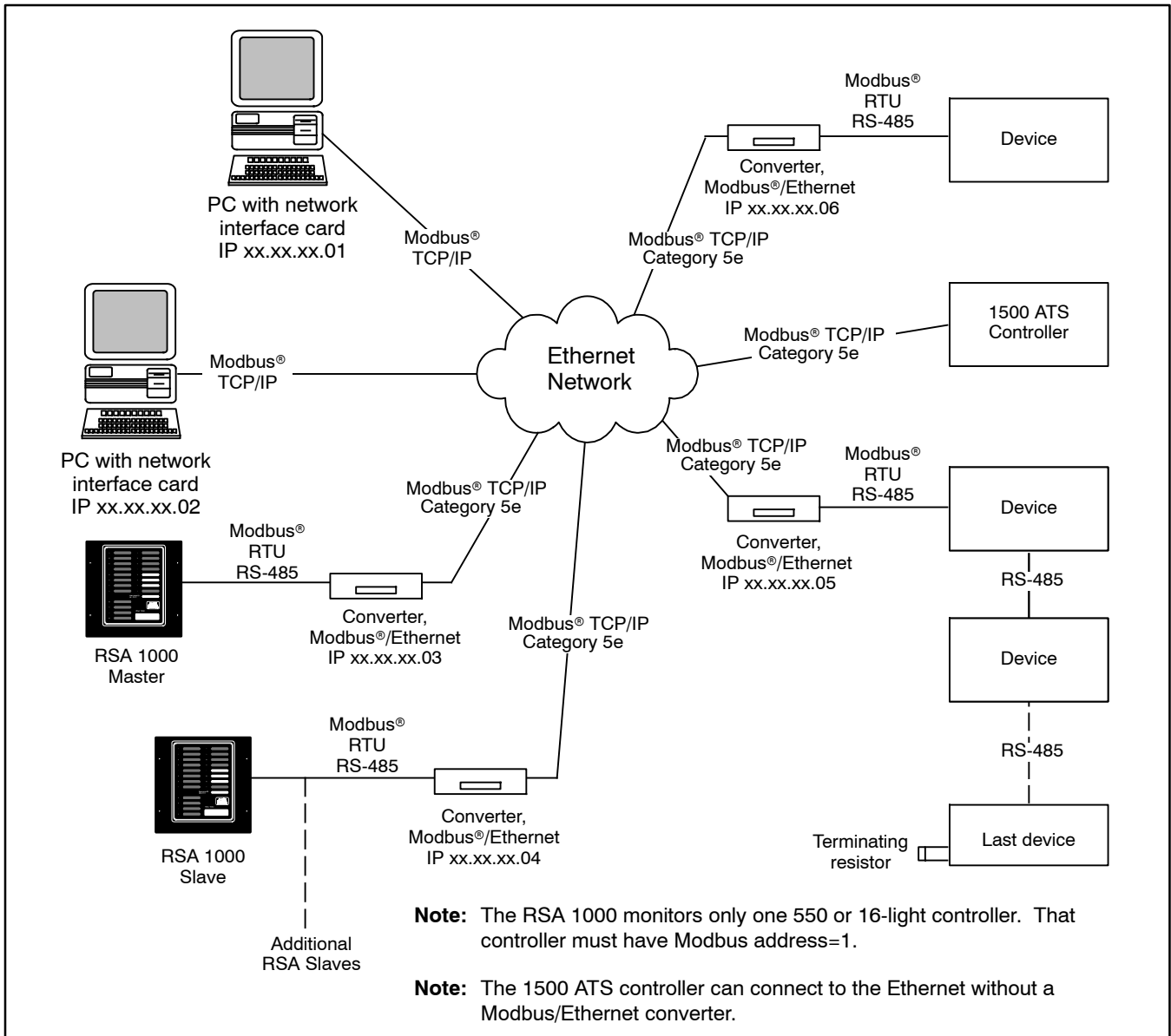

Figure 1-5 Ethernet Connections

1.2 Serial Settings

Kohler® controllers use the settings shown in Figure 1-6.

All devices in a network must use the same baud rate. Refer to TT-1405 or the section in this manual for your device to find the available baud rates.

Property	Setting
Data Bits	8
Parity	None
Stop Bits	1

Figure 1-6 Serial Settings

1.3 Modbus Protocol Definitions

The Kohler® devices covered by this manual use the Modbus codes listed in this document to communicate with Kohler® Monitor III software. For other Modbus applications, the Modbus master must be programmed to read the Modbus registers shown in this manual. A system designer trained in the application of Modbus® protocol must write and thoroughly test the program before implementation.

The tables in Sections 4 through 11 document the generator set controller information available using the Modbus® protocol.

In the tables, all word (16-bit) expressions are integers unless otherwise noted and are shown in decimal notation unless otherwise noted. Hexadecimal expressions begin with 0x. Characters are in the standard 8-bit ASCII character set. Unspecified bytes are undefined, such as the high (most significant) byte of holding registers that contain byte data in the low (least significant) byte.

This section defines terms and symbols found used in the Modbus register tables.

Register. Modbus® registers are 16-bit registers and are numbered consecutively. Request no more than 50 registers at one time. Registers are grouped into blocks of related data. Do not read registers past the end of the block where noted in the tables.

Access. The access column shows the type of access allowed to the register. RO is read only, WO is write only, and RW is read and write.

Data Description. The data description column describes the information located at the address.

Data Type. The data type column indicates whether the parameter is a WORD, SWORD, or LONG. See Figure 1-7. If multiple registers are used, the data type column shows the number of words used (e.g. WORD*10), and the range/units/notes column provides a breakdown of the information available within the parameter.

Data Type	Description
WORD	16-bit unsigned (neither positive nor negative) value
SWORD	16-bit signed (two's complement) value
LONG	32-bit unsigned value. The least significant word (LSW) is first (at the lowest address).

Figure 1-7 Data Types

WORD [0:15]. Represents a 16-bit word that may be divided to contain several items. Bits 0 through 15 are arranged right-to-left, with bit 0 on the right. See Figure 1-8.

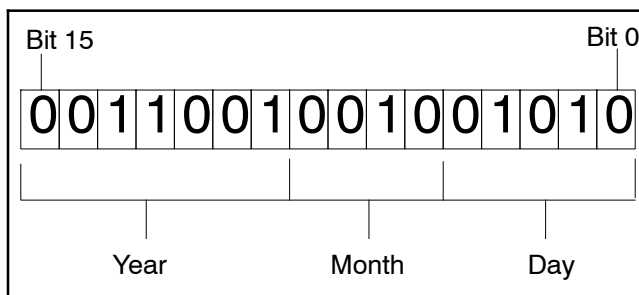

Figure 1-8 16-Bit Word Containing Date
10 February, 2025 (see the example)

Example: From Section 9.4, MPAC® 1000 register number 41320 contains the system start date. Bits 0 through 4 contain the date of the month, 0–31, represented in binary format. Bits 5 through 8 contain the month, 1–12. Bits 9–15 give the year, starting with the year 2000 (number 0) and extending through 2127 (number 127). For example, the 10th of February, 2025, would be represented as shown in Figure 1-8.

Metric or English Units. The controller display setting determines whether the units are returned or interpreted as metric or English. Read or alter this setting in register 40139 (550 controller only).

Pipe (|). A pipe symbol (|) indicates the breakdown of data within a word, with the most significant byte first. For example, min.|sec means that the most significant byte contains minutes and the least significant byte contains seconds. In the 550 controller defined common fault registers, selected|setpoint shows that the first byte indicates whether a given fault has been assigned to the defined common fault, and the last byte indicates the setpoint value for that item.

Pipe Example: Refer to address 40113 for the 550 controller. The table shows that the current date starts at register 40113 and that the date requires two words, or two registers. Register 40113 contains day|month and register 40114 contains year (two-digits)|day of the week.

Using the read holding registers function to read two registers gives the following **hexadecimal** data:

```
Register 40113: 190C
Register 40114: 0102
```

The most significant byte of register 40113 is 19 hexadecimal, which equals 25. This is the day. The least significant byte of register 40113 is 0C hexadecimal, which equals 12. This is the month, December.

The most significant byte of register 40114 is 01 hexadecimal, which equals 1. This gives the year, 2001. The least significant byte of register 40114 is 02 hexadecimal, which equals 2. This gives the day of the week, Tuesday(0= Sunday.)

The date is December 25, 2001, a Tuesday.

Setpoints. Setpoints are non-zero values only for analog inputs. The setpoint values for the analog inputs are:

- 1=Low Warning
- 2=High Warning
- 3=Low Shutdown
- 4=High Shutdown

All other setpoint values are zero (0=none).

Strings. Strings are character data represented in standard ASCII code. Strings are written as they appear on the controller display, with spaces used to pad to the right. The first character in a string is located in the most significant byte in the first register. The last character is located in the least significant byte of the last word.

Range/Units. This column lists additional information about the register type when applicable. For example, if multiple WORDs are used, this column describes the information stored in each WORD. It also lists the units for measurements that have them, the range for valid input or output when applicable, and the scale factor for some parameters. Bit 0 is the least significant bit and bit 15 is the most significant.

Ranges and Bits. Some registers list a range of items with a bit set for each item. Interpret the first number in the range as corresponding to Bit 0 and the last number in the range as corresponding to Bit 15. See Section 4.5.6, System Event Codes, for an example.

ECM only. This notation indicates that the item is available only for generator sets equipped with engine control modules (ECMs).

Device ID. Register 49999 contains the device ID for the devices shown in Figure 1-9. The device ID for 340-series devices is set with DIP switches on the Modbus/KBUS converter. See TT-1405, Installation Instructions, provided with the converter.

Controller	Device ID in Register 49999
Decision-Maker®3+	18
MPAC™ 1000	19
Decision-Maker®550	20
MPAC™ 1500	23
Decision-Maker® 3000	37
Decision-Maker® 6000	41

Figure 1-9 Device ID

1.4 Modbus Functions and Exception Codes

The controllers support the Modbus® functions listed in Figure 1-10. The controller sends exception codes to the Modbus® master to indicate errors. Figure 1-11 lists the exception codes and possible causes.

Modbus® Function	Function Name	Description
03	Read Holding Registers	Reads a single register or a range of registers.
06	Preset Single Register	Sets the value of a single register. Use this function to set all data occupying a single register.
16	Preset Multiple Registers	Sets the value of a sequence of registers. Use this function to set all data occupying multiple registers. The maximum number of registers is 16.

Figure 1-10 Supported Modbus® Functions

Exception Code	Message	Possible Causes
01	Illegal Function	Violates the register access type. Attempts to write registers when the controller programming mode is not set to remote. Attempts to write too many registers using Preset Multiple Registers. The maximum number of registers is 16. Function is not supported.
02	Illegal Data Address	Attempts to read too many registers. The maximum is 50. Attempts to access a nonexistent register.
03	Illegal Data Value	Attempts to set a register to a value outside of the allowable limits. Attempts to set system parameters while the generator set is not in OFF or AUTO. Specifies an incorrect number of registers while attempting to read or write data occupying a sequence of registers. Attempts to modify digital input while the input is high. Attempts to modify analog input while the input is out of range. Attempts to modify preset input that cannot be changed. Attempts to read outside a restricted block. Attempts to define an invalid common fault. Attempts to activate an RDO that is not software-controlled. Attempts to start the engine while the timed run is active.

Figure 1-11 Supported Modbus® Exception Codes

Section 2 Decision-Maker 3+ Controller with Communications

2.1 Introduction

Decision-Maker® 3+ 16-Light controllers equipped with red main logic boards and a communication board have Modbus® communication capability. The controller:

- Requires the red logic board and a communication board for Modbus communication.
- Supports industry-standard Modbus® RTU protocol.
- Can use Modbus® TCP protocol with the addition of a Modbus/Ethernet converter.
- Uses RS-485 connections to connect to a Modbus® master singly or over an RS-485 network.
- Connects to an Ethernet network using a Modbus/Ethernet converter.
- Uses 19200 baud rate.

The communication board is required for Modbus® communication with this controller. See Figure 2-2 and Figure 2-3. The communication board accessory kits are:

- GM32644-KA1 or KA2 (factory-installed)
- GM32644-KP1 (field-installed)

The kit includes the communication board, cables, mounting hardware, and installation instructions.

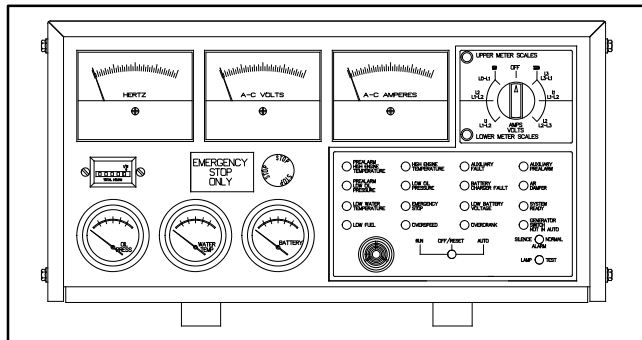

Figure 2-1 Decision-Maker® 3+ Controller

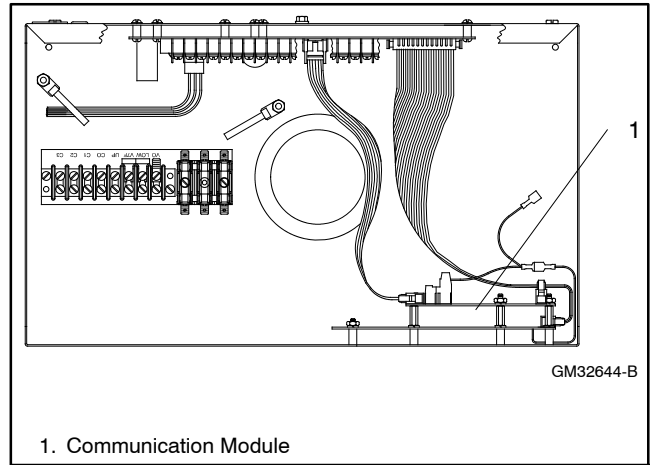

Figure 2-2 Communication Board Location (Controller Top View)

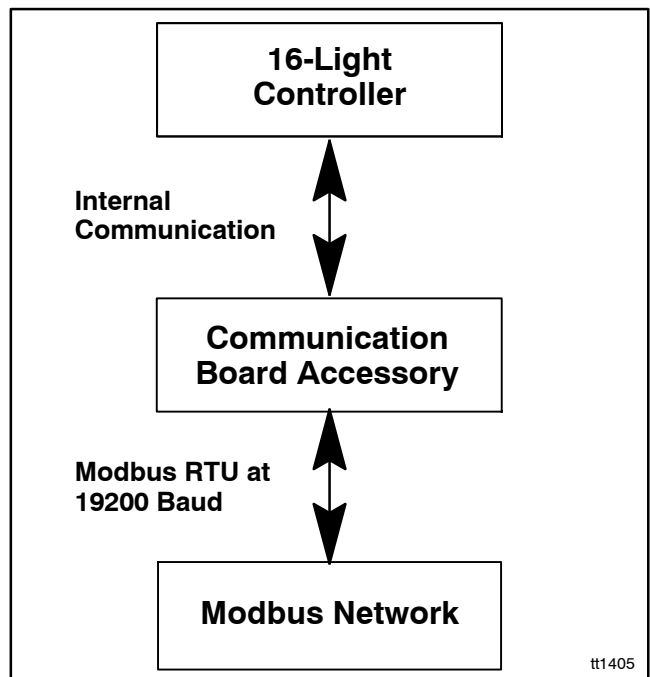

Figure 2-3 Communication Board Function

2.2 Communication Board Identification

Selected generator set models may be equipped with a gauge driver board, which does not provide Modbus® communication. The gauge driver board looks similar to the communication boards shown in Figure 2-4 and is installed in the same location. To identify the board, check the part number on the printed circuit board (PCB) and see Figure 2-5. Part numbers GM47242 and GM49791-1 are Modbus® communication boards. Gauge driver board part number GM49791-2 does **not** provide Modbus® communication. Obtain kit GM32644-KP1 to replace the gauge driver board, if necessary.

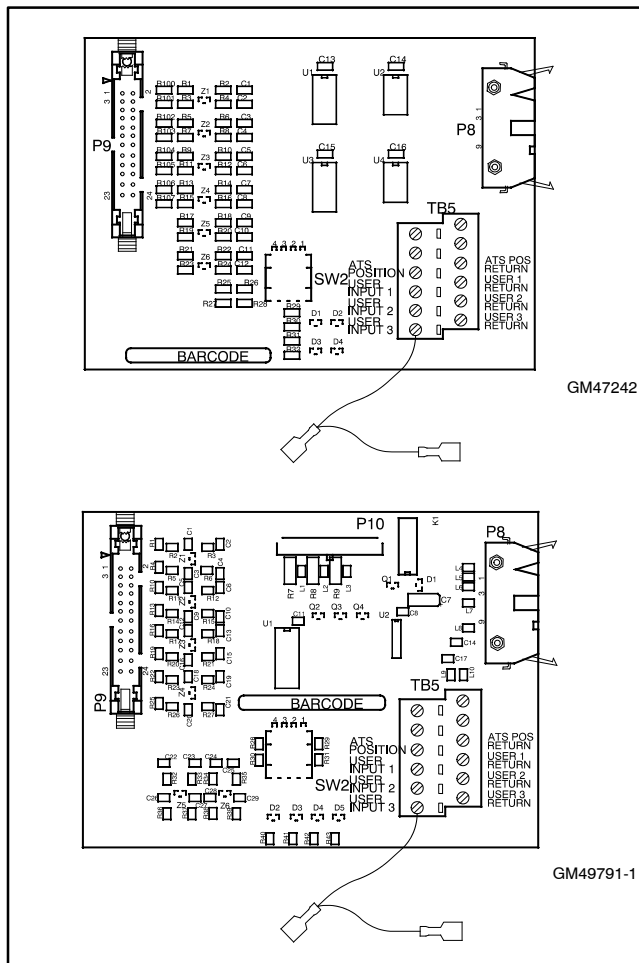

Figure 2-4 Communication Boards

PCB Part No.	Description
GM47242	Communication Board. Superseded by GM49791-1.
GM49791-1	Communication and Gauge Driver Board
GM49791-2	Gauge Driver Board (no Modbus communication)

Figure 2-5 PCB Board Identification

2.3 Controller Connection and Setup

This section describes how to connect the controller to other devices in a Modbus® network and set up the controller for Modbus® communication. Refer to TT-1377, provided with the communication module, for additional information.

⚠ WARNING



Accidental starting.
Can cause severe injury or death.

Disconnect the battery cables before working on the generator set. Remove the negative (-) lead first when disconnecting the battery. Reconnect the negative (-) lead last when reconnecting the battery.

Disabling the generator set. Accidental starting can cause severe injury or death. Before working on the generator set or connected equipment, disable the generator set as follows: (1) Move the generator set master switch to the OFF position. (2) Disconnect the power to the battery charger. (3) Remove the battery cables, negative (-) lead first. Reconnect the negative (-) lead last when reconnecting the battery. Follow these precautions to prevent starting of the generator set by an automatic transfer switch, remote start/stop switch, or engine start command from a remote computer.

⚠ DANGER



Hazardous voltage.
Will cause severe injury or death.

Disconnect all power sources before opening the enclosure.

Grounding electrical equipment. Hazardous voltage can cause severe injury or death. Electrocutation is possible whenever electricity is present. Ensure you comply with all applicable codes and standards. Electrically ground the generator set, transfer switch, and related equipment and electrical circuits. Turn off the main circuit breakers of all power sources before servicing the equipment. Never contact electrical leads or appliances when standing in water or on wet ground because these conditions increase the risk of electrocution.

NOTICE

Electrostatic discharge damage. Electrostatic discharge (ESD) damages electronic circuit boards. Prevent electrostatic discharge damage by wearing an approved grounding wrist strap when handling electronic circuit boards or integrated circuits. An approved grounding wrist strap provides a high resistance (about 1 megohm), *not a direct short*, to ground.

2.3.1 Network Connection

Use Belden #9841 or equivalent cable to connect to other devices in an RS-485 network. Connect to the TB5 connector on the controller circuit board shown in Figure 2-6. Attach to the RS-485 connector as shown in Figure 2-7. Use a termination resistor on the last device in the network.

Circuit isolation is recommended for installations that may be exposed to electrical noise. See Appendix B, Noise and Wiring Practices.

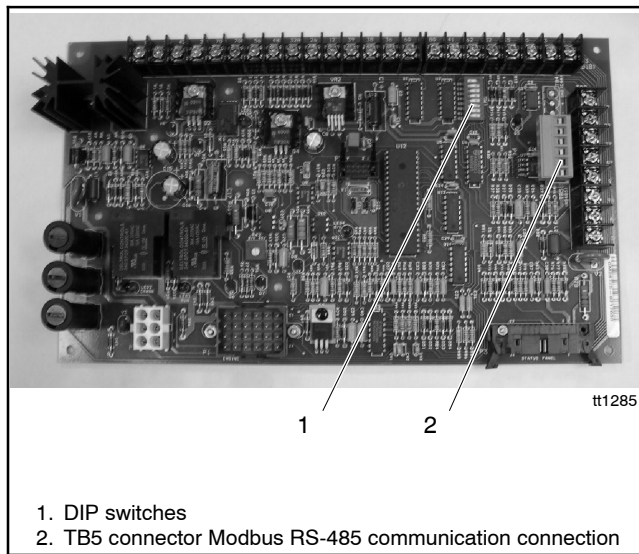

Figure 2-6 Decision-Maker® 3+ Controller Circuit Board with DIP Switches

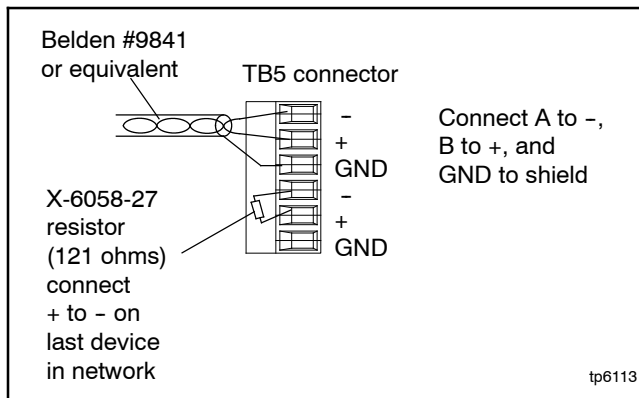

Figure 2-7 RS-485 Connection Details

2.3.2 Controller Setup

The controller circuit board contains eight DIP switches. Use DIP switches 6, 7, and 8 to set the controller's Modbus® address as described below. See Figure 2-6 for the DIP switch location on the controller circuit board.

Each Modbus® device in the network requires a unique address. Use DIP switches 6, 7, and 8 to assign a unique Modbus® address to each controller in the network. Figure 2-8 shows the DIP switch positions for each address number.

Push down the end of the DIP switch near the OPEN label to open the switch, or push down the other end to close it. See Figure 2-9.

Modbus® Address	DIP Switches		
	6	7	8
	Value = 2	Value = 4	Value = 8
1	Open	Open	Open
3	Closed	Open	Open
5	Open	Closed	Open
7	Closed	Closed	Open
9	Open	Open	Closed
11	Closed	Open	Closed
13	Open	Closed	Closed
15	Closed	Closed	Closed

Figure 2-8 Modbus® Address DIP Switches

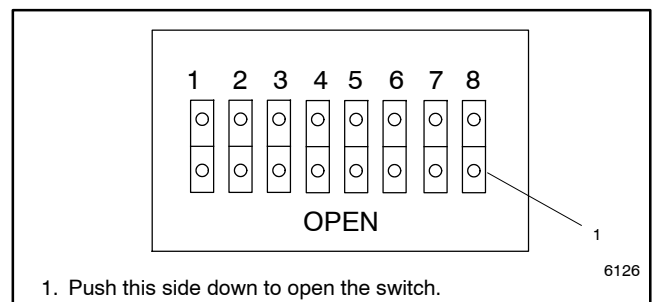

Figure 2-9 DIP Switch Operation

2.4 Modbus Registers and Codes

Refer to Section 1.3 for definitions of terms and symbols used in the register tables.

This section contains Modbus® registers and codes for the Decision-Maker® 3+ controller with communications.

2.4.1 Modbus Registers

Register	Parameter	Access	Data Type	Range/Units
40001	System status	RO	WORD (0:3)	0: Set if in run mode, otherwise cleared 1: Set if in cooldown mode, otherwise cleared 2: 0 = 50 Hz; 1 = 60 Hz 3: Set if continuous crank enabled, Cleared if cyclic crank enabled 4: Set if generator running 5: Set if system ready
40002	Remote input status	RO	WORD[0:15]	0: Common fault 1: Low fuel 2: Battery charger fault 3: Low battery voltage 4: Air damper switch 5: Low coolant temperature (non-ECM and J1939) 6: Pre-high coolant temperature (non-ECM) 7: Emergency stop 8: ATS Emergency on 9: User Input #1 10: User Input #2 11: User Input #3 (dedicated to high battery voltage) 12: Communications module DIP switch #1 status 13: Communications module DIP switch #2 status 14: Communications module DIP switch #3 status 15: Communications module DIP switch #4 status
40003	Master switch position	RO	WORD	0 = Fault; 1 = Run; 2 = Auto; 4 = Off
40004	Engine RPM	RO	WORD	0-4000 RPM
40005	Shutdown fault number	RO	WORD	See S/D Fault Code Table, Section 2.4.2, and Section 2.4.3
40006	Flags and warnings	RO	WORD	See Flags/Warnings Code Table, Section 2.4.4. Condition exists if bit is set.
40007	Oil pressure	RO	WORD	kPa
40008	Coolant temperature	RO	WORD	°C + 273
40009	Fuel pressure	RO	WORD	kPa
40010	Fuel temperature	RO	WORD	°C + 273
40011	Charge air pressure	RO	WORD	kPa
40012	Charge air temperature	RO	WORD	°C + 273
40013	ECM supply voltage	RO	WORD	VDC * 10 (0.0 - 99.9 VDC)
40014-40015	ECM hours	RO	WORD * 2	Hrs * 10 (0.0 - 99999.9 hr.) (most significant word first)
40016	ECM temperature	RO	WORD	°C + 273
40017	MDEC/ADEC fault codes	RO	WORD	See MDEC/ADEC engine documentation and Section 2.4.3
40018	Engine communication protocol	RO	WORD	0 = Non ECM; 1 = MTU; 2 = J1939; 3 = MTU w/VSG
40019	Code version	RO	WORD	0-7: Minor version 8-15: Major version
40020	Manual operations	WO	WORD[0:2]	0: Remote start 1: Remote stop 2: Remote fault reset
49999	Device ID	RO	WORD	Decision-Maker® 3+ = 18

2.4.2 Shutdown Fault Codes

Fault Codes	Description
0	No faults present
1	Master switch not in auto (warning)
2	Master switch error
3	Overcrank
4	Locked rotor
5	Overspeed
6	Low oil pressure prealarm (warning)
7	Low oil pressure shutdown
8	High coolant temperature prealarm (warning)
9	High coolant temperature shutdown
10	Low coolant temperature (warning)
11	Aux. delay
12	Aux. immediate
13	MDEC/ADEC yellow alarm (warning)
14	MDEC/ADEC red alarm
15	Loss of ECM comms

2.4.3 MDEC/ADEC Fault Codes

Fault Condition	Register 40005	Register 40017	Controller Response
Loss of ECM communications	15	—	Auxiliary Fault LED on steady, horn on.
High engine temperature prealarm	—	67	High Engine Temperature Prealarm LED on steady, horn on.
High engine temperature shutdown	9	68	High Engine Temperature Prealarm and Shutdown LED's on steady, horn on.
Low engine temperature prealarm	—	—	Low Water Temperature LED on steady, horn on.
Low engine temperature shutdown	14	—	Low Water Temperature and Auxiliary Fault LED's on steady, horn on.
Overspeed shutdown	5	30	Overspeed LED on steady, horn on.
Low oil pressure prealarm	—	15	Low Oil Pressure Prealarm LED on steady, horn on.
Low oil pressure shutdown	7	16	Low Oil Pressure Prealarm and Shutdown LED's on steady, horn on.
Low fuel pressure prealarm	—	See MDEC/ADEC documentation	Auxiliary Fault LED flashing, horn cycling on/off.
Low fuel pressure shutdown	—	See MDEC/ADEC documentation	Auxiliary Fault LED on steady, horn on.
High charge air temperature prealarm	—	5	Auxiliary Fault LED flashing, horn cycling on/off.
High charge air temperature shutdown	14	6	Auxiliary Fault LED on steady, horn on.
Low coolant level shutdown	14	24	Auxiliary Fault LED on steady, horn on.
High lube oil temperature prealarm	—	51	Auxiliary Fault LED flashing, horn cycling on/off.
Generic MDEC/ADEC yellow alarm (prealarm)	—	See MDEC/ADEC documentation	Auxiliary Fault LED flashing, horn cycling on/off.
Generic MDEC/ADEC red alarm (shutdown)	14	See MDEC/ADEC documentation	Auxiliary Fault LED on steady, horn on.

2.4.4 Flags/Warnings

Warning Bits	Description
Bit 0 (LSB)	No AC voltage
Bit 1	MDEC/ADEC yellow alarm
Bit 2	Speed sensor fault
Bit 3	Intermittent speed sensor
Bit 4	Master switch not in auto
Bit 5	MDEC/ADEC charge air temperature warning
Bit 6	MDEC/ADEC low fuel pressure warning
Bit 7	MDEC/ADEC high oil temperature warning
Bit 8	Low oil pressure warning
Bit 9	High coolant temperature warning (MDEC/ADEC and J1939)
Bit 10	Low coolant temperature warning (MDEC/ADEC)
Bit 11	Unused
Bit 12	Unused
Bit 13	Unused
Bit 14	Unused
Bit 15 (MSB)	Unused

Section 3 Decision-Maker 340 Generator Set Controller

3.1 Introduction

The Decision-Maker® 340 controller uses KBUS protocol for communication. Modbus/KBUS converter kit GM41143-KP3 is required for Modbus communication with this controller. See Figure 3-2.

Installing the Modbus®/KBUS converter kit allows this controller to communicate with a personal computer running Monitor III software. For other Modbus applications, the Modbus master must be programmed to read the Modbus registers shown in this manual. A system designer trained in the application of Modbus® protocol must write and thoroughly test the program before implementation.

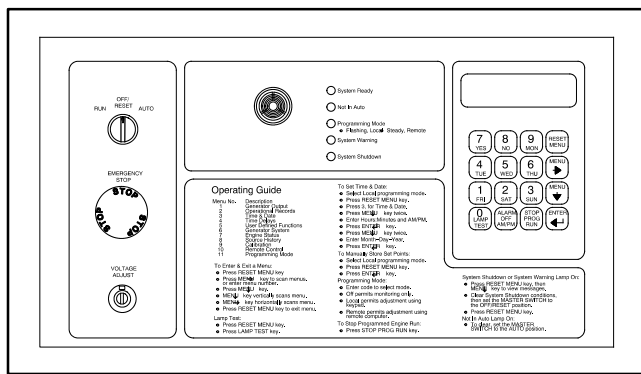

Figure 3-1 Decision-Maker 340 Controller

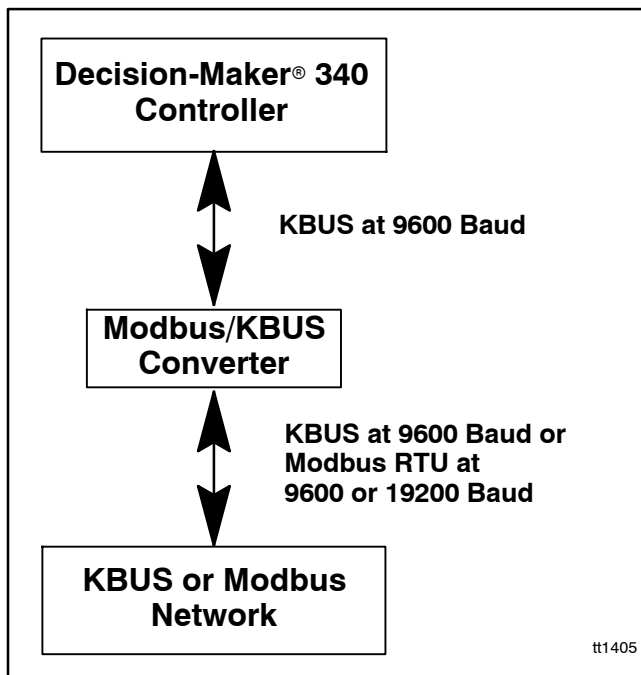

Figure 3-2 Modbus/KBUS Converter Function

3.2 Hardware and Connections

The Modbus/KBUS converter replaces RS-232 and RS-485 communication modules and allows the selection of either KBUS or Modbus communication. Figure 3-3 shows the Modbus/KBUS converter circuit board. See Figure 3-4 for the converter location inside the controller.

If your device is equipped with an RS-232/RS-485 communication module, remove the old communication module and ribbon cable before installing the new Modbus/KBUS converter and ribbon cable.

Refer to Installation Instructions TT-1405, provided with the converter kit, for converter installation and connection instructions. Set the converter DIP switches for baud rate, device type, and network address as described in TT-1405.

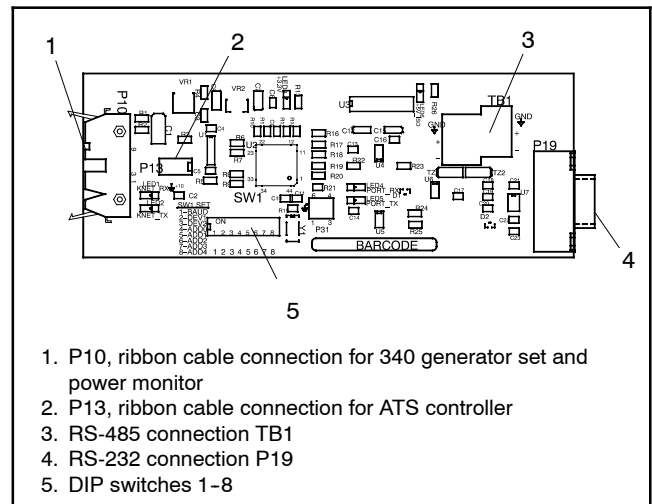
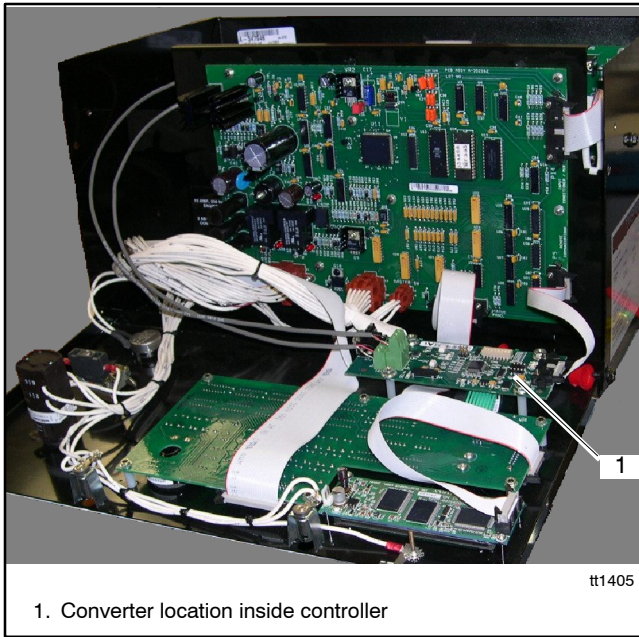

Figure 3-3 Modbus/KBUS Converter Board

1. P10, ribbon cable connection for 340 generator set and power monitor
2. P13, ribbon cable connection for ATS controller
3. RS-485 connection TB1
4. RS-232 connection P19
5. DIP switches 1-8



1. Converter location inside controller

Figure 3-4 Modbus/KBUS Converter Location

Device	Menu or Index	Parameter	Setting
Decision-Maker® 340 generator set controller	Menu 10, Remote Control	Remote Control: Online?	YES
		Remote Control: Local, LAN, Remote, or Remote Area Network?	Select the appropriate setting for your connection type. Use Local for Ethernet connections. See TT-1405 for more information.
		Address	Any *
		Baud rate	9600 †
* The network address for Series 340 devices is set using DIP switches on the converter module and will override the network address on the controller.			
† This baud rate must be set at 9600 to match the KBUS side of the Modbus/KBUS converter. It may be different from the Modbus baud rates of other devices in the system.			

Figure 3-5 Controller Settings for Modbus Communication

3.3 Controller Setup

Configure the controller for remote communications by setting the parameters shown in Figure 3-5. See TT-1405 and the controller operation manual for more information.

3.4 Modbus Registers

Refer to Section 1.3 for definitions of terms and symbols used in the register tables.

Register	Data Description	Access	Data Type	Range/Units
40001				
40002	System Time	RO	WORD	
40003	Day of Week	RO	WORD	
40004	Month	RO	WORD	1-12
40005	Day	RO	WORD	1-31
40006	Year	RO	WORD	
40007	Week of Month	RO	WORD	
40008	Voltage L1-L2	RO	WORD	Volts
40009	Voltage L2-L3	RO	WORD	Volts
40010	Voltage L3-L1	RO	WORD	Volts
40011	Frequency	RO	WORD	Hz
40012	Voltage L1-L0	RO	WORD	Volts
40013	Voltage L2-L0	RO	WORD	Volts
40014	Voltage L3-L0	RO	WORD	Volts
40015	Alert Code	RO	WORD	Alert Code
40016	Engine Speed	RO	WORD	
40017	Coolant Temp	RO	WORD	
40018	Oil Pressure	RO	WORD	
40019	Battery Voltage	RO	WORD	VDC * 10
40020	L1 Current	RO	WORD	Amps
40021	L2 Current	RO	WORD	Amps
40022	L3 Current	RO	WORD	Amps
40023	Power Factor	RO	WORD	* 100
40024	Total Real Power	RO	WORD	kW
40025	Percent of Max. Power	RO	WORD	% * 100
40034	Status	RO	WORD[0-7]	0-1: Sw. Position (00=open; 01=auto; 10=run; 11=off) 2-3: Gen. Status (00=stopped; 01=running; 10=crank; 11=undefined) 4-5: Program Mode (00=off; 01=remote; 10=local; 11=undefined)
40048	Engine Start Time	RO	WORD	Sec
40049	Crank Time	RO	WORD	Sec
40050	Crank Pause Time	RO	WORD	Sec
40051	Num of Crank Cycles	RO	WORD	
40052	Engine Cooldown Time	RO	WORD	Sec
40053	Over Voltage Time Delay	RO	WORD	Sec
40054	Under Voltage Time Delay	RO	WORD	Sec
40055	Starting Aid Time	RO	WORD	Sec
40056	Aux 1 Inhibit Time	RO	WORD	Sec
40057	Aux 1 Delay Time	RO	WORD	Sec
40058	Aux 2 Inhibit Time	RO	WORD	Sec
40059	Aux 2 Delay Time	RO	WORD	Sec
40060	Aux 3 Inhibit Time	RO	WORD	Sec
40061	Aux 3 Delay Time	RO	WORD	Sec
40062	Aux 4 Inhibit Time	RO	WORD	Sec
40063	Aux 4 Delay Time	RO	WORD	Sec
40064	Over Voltage Trip Point	RO	WORD	%, 105-135
40065	Under Voltage Trip Point	RO	WORD	%, 70-95
40066	Over Freq Trip Point	RO	WORD	%, 102-140

Register	Data Description	Access	Data Type	Range/Units
40067	Under Freq Trip Point	RO	WORD	%, 80-98
40068	Over Speed Trip Point	RO	WORD	%, 55-70 <---?
40069	Low Battery Voltage Trip Point	RO	WORD	VDC * 10
40070	High Battery Voltage Trip Point	RO	WORD	VDC * 10
40071	System Voltage	RO	WORD	Volts, 105-14600
40072	System Frequency	RO	WORD	Hz, 48-62
40073	Genset Rating	RO	WORD	kW, 0-3000
40074	Battery Voltage	RO	WORD	VDC, 12 or 24
40076	Run Time Loaded Since Reset	RO	WORD*2	
40078	Run Time Unloaded Since Reset	RO	WORD*2	
40080	Days of Operation Since Reset	RO	WORD	
40081	kW-Hrs Since Reset	RO	WORD*2	
40083	Number Starts Since Reset	RO	WORD	
40084	Month of Reset	RO	WORD	1-12
40085	Day of Reset	RO	WORD	1-31
40086	Year of Reset	RO	WORD	
40087	Run Time Loaded Since Startup	RO	WORD*2	
40089	Run Time Unloaded Since Startup	RO	WORD*2	
40091	Days of Operation Since Startup	RO	WORD	
40092	kW-Hrs Since Startup	RO	WORD*2	
40094	Number Starts Since Startup	RO	WORD	
40095	Month of Startup	RO	WORD	1-12
40096	Day of Startup	RO	WORD	1-31
40097	Year of Startup	RO	WORD	
40098	Month of Last Start	RO	WORD	1-12
40099	Day of Last Start	RO	WORD	1-31
40100	Year of Last Start	RO	WORD	
40101	Time of Last Start	RO	WORD	
40102	Duration of Last Run	RO	WORD	
40112	Shutdown #1 Code	RO	WORD	Code
40113	Shutdown #1 Month	RO	WORD	1-12
40114	Shutdown #1 Day	RO	WORD	1-31
40115	Shutdown #1 Year	RO	WORD	
40116	Shutdown #2 Code	RO	WORD	Code
40117	Shutdown #2 Month	RO	WORD	1-12
40118	Shutdown #2 Day	RO	WORD	1-31
40119	Shutdown #2 Year	RO	WORD	
40120	Shutdown #3 Code	RO	WORD	Code
40121	Shutdown #3 Month	RO	WORD	1-12
40122	Shutdown #3 Day	RO	WORD	1-31
40123	Shutdown #3 Year	RO	WORD	
40124	Shutdown #4 Code	RO	WORD	Code
40125	Shutdown #4 Month	RO	WORD	1-12
40126	Shutdown #4 Day	RO	WORD	1-31
40127	Shutdown #4 Year	RO	WORD	
40140-40144	Designation	RO	WORD*5	9 chars, 1 per byte, first char = LSB, last byte ignored
40145-40154	Load Description	RO	WORD*10	20 chars, 1 per byte, first char = LSB
40155-40164	Location	RO	WORD*10	20 chars, 1 per byte, first char = LSB
40165-40177	Model No.	RO	WORD*13	26 chars, 1 per byte, first char = LSB
40178-40185	Spec. No.	RO	WORD*8	16 chars, 1 per byte, first char = LSB
40186-40188	Serial No.	RO	WORD*3	6 chars, 1 per byte, first char = LSB
40189-40191	Controller Serial No.	RO	WORD*3	6 chars, 1 per byte, first char = LSB

Register	Data Description	Access	Data Type	Range/Units
40204-40213	Auxiliary 1 Description	RO	WORD*10	20 chars, 1 per byte, first char = LSB
40214-40223	Auxiliary 2 Description	RO	WORD*10	20 chars, 1 per byte, first char = LSB
40224-40233	Auxiliary 3 Description	RO	WORD*10	20 chars, 1 per byte, first char = LSB
40234-40243	Auxiliary 4 Description	RO	WORD*10	20 chars, 1 per byte, first char = LSB
40245	Auxiliary Function Operation	RO	WORD [0-3]	0 = shutdown; 1 = warning (one bit per function)
40264	Relay Driver #1 Code	RO	WORD	Code
40265	Relay Driver #2 Code	RO	WORD	Code
40266	Relay Driver #3 Code	RO	WORD	Code
40267	Relay Driver #4 Code	RO	WORD	Code
40268	Relay Driver #5 Code	RO	WORD	Code
40269	Relay Driver #6 Code	RO	WORD	Code
40270	Relay Driver #7 Code	RO	WORD	Code
40271	Relay Driver #8 Code	RO	WORD	Code
40272	Relay Driver #9 Code	RO	WORD	Code
40273	Relay Driver #10 Code	RO	WORD	Code
40274	Common Fault #1 Code	RO	WORD	Code
40275	Common Fault #2 Code	RO	WORD	Code
40276	Common Fault #3 Code	RO	WORD	Code
40277	Common Fault #4 Code	RO	WORD	Code
40278	Common Fault #5 Code	RO	WORD	Code
40279	Common Fault #6 Code	RO	WORD	Code
40300	Run Time	WO	WORD	Min
40350	Reset Faults	WO	WORD[0]	0: 1=reset faults; 0=ignored

3.5 Alert Codes

Code	Message Summary
0	Defined Common Fault
1	Air Damper
2	Over Voltage
3	Under Voltage
4	Under Frequency Shutdown
5	Low Coolant Level
6	High Oil Temperature
7	Auxiliary 1
8	Auxiliary 2
9	Auxiliary 3
10	Auxiliary 4
11	Locked Rotor
12	Internal Error
13	EPS Supplying Load
14	Speed Sensor Fault
15	Load Shed
16	kW Overload
17	Under Frequency Warning
18	High Battery Voltage
19	Coolant Temperature Signal Loss
20	Oil Pressure Signal Loss
21	Ground Fault Detected
22	Over Current
23	Engine Cooldown
24	Time Delay Engine Start
25	Generator Running
26	NFPA 110 Common Alarm
27	Starting Aid
28	Low Oil Pressure
29	High Coolant Temperature

Code	Message Summary
30	Overcrank
31	Overspeed
32	Emergency Stop
33	Not In Auto
34	System Ready
35	Low Battery Voltage
36	Battery Charger Fault
37	Low Fuel
38	High Coolant Temperature Warning
39	Low Oil Pressure Warning
40	Low Coolant Temperature
41	Weak Battery
42	Load Shed Underfrequency
43	Load Shed Excess kW
44	Low AC Output
45	Overvoltage L1-L2
46	Overvoltage L2-L3
47	Overvoltage L3-L1
48	Overvoltage L1-L0
49	Overvoltage L2-L0
50	Overvoltage L3-L0
51	Undervoltage L1-L2
52	Undervoltage L2-L3
53	Undervoltage L3-L1
54	Undervoltage L1-L0
55	Undervoltage L2-L0
56	Undervoltage L3-L0
57	Master Switch Open (OFF/RESET)
58	Power-Down Error
59	Overfrequency Shutdown

Section 4 Decision-Maker 550 Generator Set Controller

4.1 Specifications

The Decision-Maker® 550 controller's Modbus® communication capability:

- Supports industry-standard Modbus® RTU protocol.
- Can use Modbus® TCP protocol with the addition of a Modbus/Ethernet converter.
- Connects to a Modbus® master singly over an RS-232 line.
- Uses RS-485 connections to connect to a Modbus® master singly or over an RS-485 network.
- Connects to an Ethernet network using a Modbus/Ethernet converter.
- Can operate as an RS-232 to RS-485 converter.
- Uses standard baud rates of 9600 or 19200.

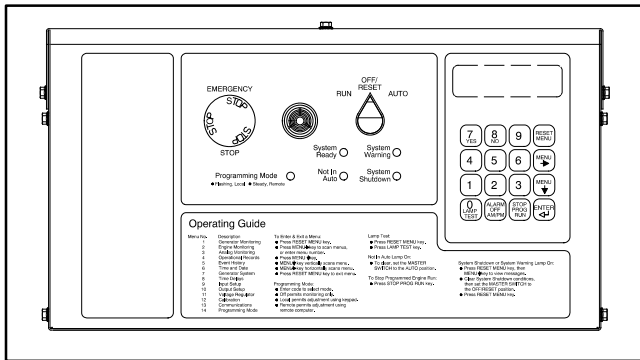

Figure 4-1 Decision-Maker® 550 Controller

4.2 Hardware Connections

⚠ WARNING



**Accidental starting.
Can cause severe injury or death.**

Disconnect the battery cables before working on the generator set. Remove the negative (-) lead first when disconnecting the battery. Reconnect the negative (-) lead last when reconnecting the battery.

Disabling the generator set. Accidental starting can cause severe injury or death. Before working on the generator set or connected equipment, disable the generator set as follows: (1) Move the generator set master switch to the OFF position. (2) Disconnect the power to the battery charger. (3) Remove the battery cables, negative (-) lead first. Reconnect the negative (-) lead last when reconnecting the battery. Follow these precautions to prevent starting of the generator set by an automatic transfer switch, remote start/stop switch, or engine start command from a remote computer.

Plan the connections and refer to Figure 1-1 through Figure 1-4 to identify the cables needed. Use either an RS-232 cable or the supplied RS-485 connector with Belden #9841 or equivalent cable for a single connection. Use the RS-485 connector and Belden #9841 or equivalent cable to connect devices in a network. Attach the RS-485 connectors as shown in Figure 4-2. Use the termination resistor on the last device in the network.

Circuit isolation is recommended for installations that may be exposed to electrical noise. See Appendix B, Noise and Wiring Practices.

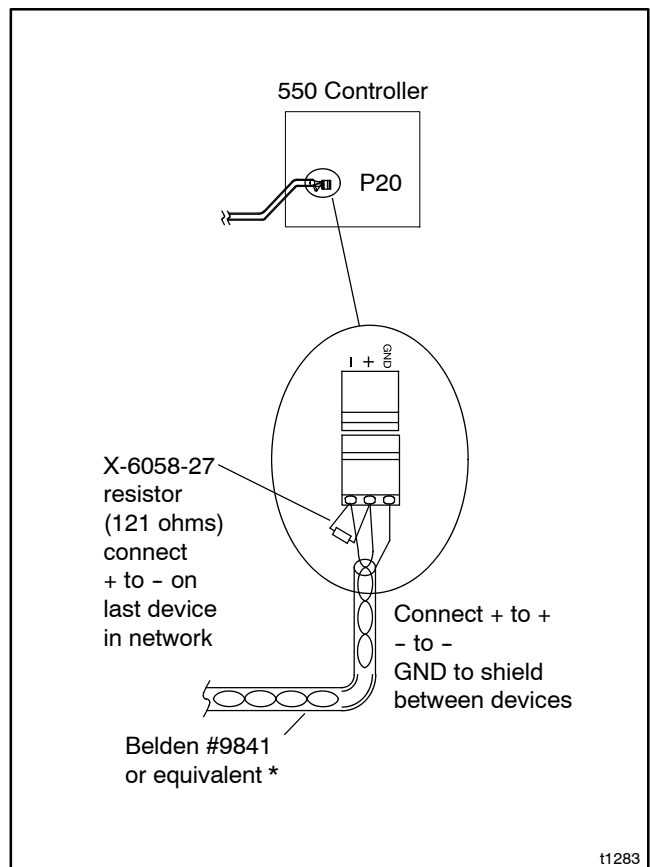

Figure 4-2 RS-485 Connector Details

Use the following procedure to connect the hardware. Observe the safety precautions.

Controller Connection Procedure

1. Place the generator set master switch in the OFF position.
2. Disconnect the power to the battery charger, if equipped.
3. Disconnect the generator set engine starting battery(ies), negative (-) lead first.
4. Turn off and disconnect the power to all devices in the system.
5. Open the enclosure and locate the connection ports as shown in Figure 4-3 and Figure 4-4.
6. Make connections to the desired controller port(s). For RS-232 connections, use connector P18. For RS-485 connections, use the Modbus® RS-485 connector, P20 (connectors P19 and P21 are used for other applications).
7. Close the controller enclosure.
8. Check that the generator set master switch is in the OFF position.

9. Reconnect the generator set engine starting battery, negative (-) lead last.
10. Reconnect power to the battery charger, if equipped.

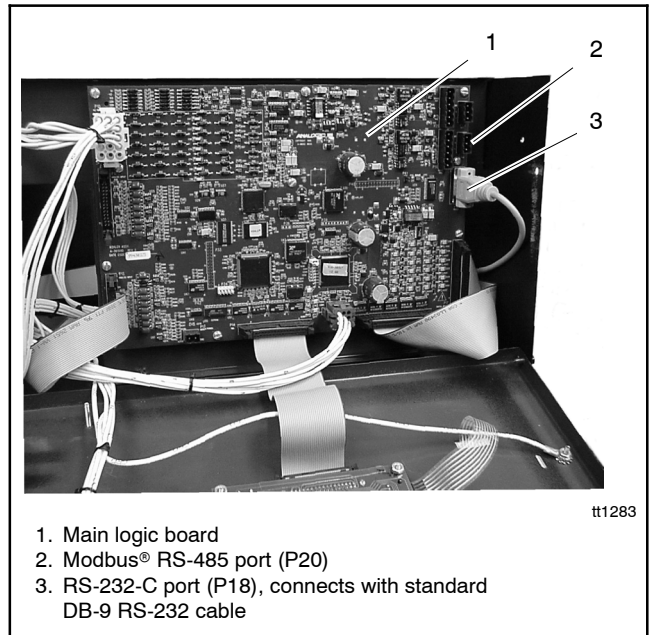

Figure 4-3 Communication Port Locations for Decision-Maker™ 550 Generator Set Controller

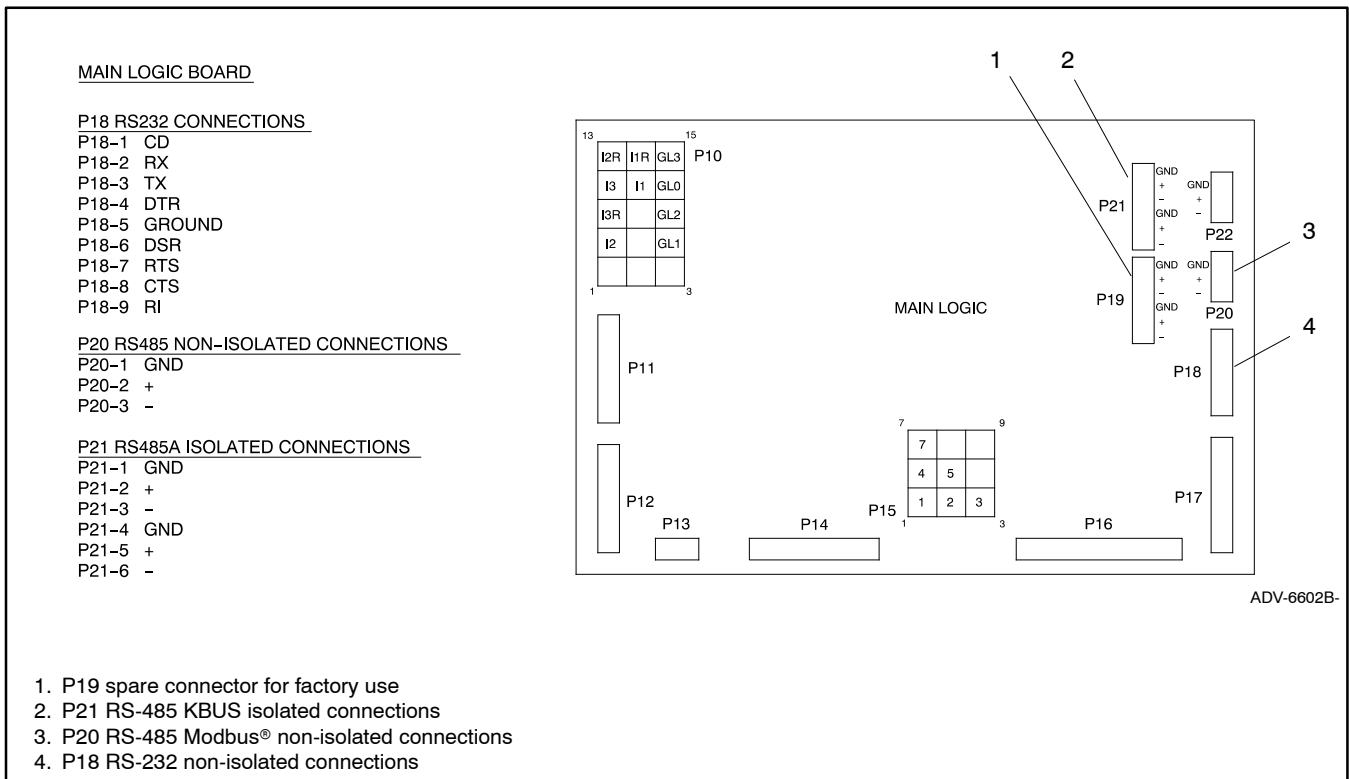

Figure 4-4 Communication Connections Pin Identification

4.3 Controller Setup

After connecting the hardware, set up the controller. Enter the communication settings shown in the procedure below. Refer to the controller operation manual for detailed instructions on how to enter settings through the controller keypad.

Note: Changing the programming mode requires entering the generator set controller access code. Refer to the controller operation manual for more information.

Controller Setup Procedure

1. Go to Menu 14—Programming Mode using the controller keypad. Enter the local programming mode to allow changes to the controller communication settings.
 2. Enter the controller access code when prompted by the controller.
 3. Go to Menu 13—Communications.
 4. Use the MENU arrow buttons to move to the Protocol Modbus® heading.
 5. Enter Yes at the Modbus® Online Y/N display.
 6. Choose the connection type. Choose Converter and proceed to step 8 if the controller is converting RS-232 to RS-485. Otherwise, choose Single and proceed to step 7.
- Note:** The controller automatically selects RS-232 for the primary port if Converter is chosen for the connection type.
7. Choose RS-232 or RS-485 for the primary port, which is the port connected to the Modbus® master.
 8. Enter the network address of the controller. Enter 1 (one) for a single connection.
- Note:** Use a unique network address for each unit. Use numbers between 1 and 246. Do not use 0 (zero).
9. Select the baud rate. Choose the same baud rate for the Modbus® master, modems, and connected devices .

10. Go to Menu 14—Programming Mode again. Choose either remote programming mode, local programming mode, or programming mode off as described below:
 - a. To allow the Modbus® master to read and write to the controller, choose Remote; *or*
 - b. To allow only monitoring through the Modbus® connections but local programming through the controller keypad, choose Local; *or*
 - c. To turn the programming mode off, allowing no controller programming from either the Modbus® master or the local keypad, choose Off.
11. Enter the controller access code when prompted by the controller.

4.4 Controller Application Code Versions

There are two versions of the Modbus® registers for different versions of the controller’s application code. Figure 4-5 shows where to find the Modbus register map for your unit based on the application code version number.

550 Controller Application Code Version	Location of Modbus Register Map
Below 2.10	Appendix C
2.10 or higher	Section 4.5

Figure 4-5 Register Map Locations for Different Application Code Versions

Use the following procedure to access Menu 20 to check the version number of the application code loaded on your controller.

Procedure to Identify the Controller Application Code Version

1. Use the controller keypad to access Menu 20. At the controller display Enter Menu No: 1-15, press 20 and the Enter key.
2. Use the down arrow key on the controller keypad to step through the factory setup items until Code Version is displayed.
3. Record the code version number shown for future reference.
4. Press the Reset Menu key on the controller keypad to exit the menu.

4.5 Modbus Maps for Controllers with Application Code Versions 2.10 or Higher

This section contains Modbus® registers for Decision-Maker® 550 controller with application code versions 2.10 or higher (for example, code version 2.20). See Section 4.4 for instructions to determine the application code version number for your controller.

Refer to Section 1.3 for definitions of terms and symbols used in the register tables.

Time delays, setpoints, inputs and outputs, and other user-defined parameters are entered through the controller keypad or Monitor III software. Refer to the operation manuals for the 550 controller and Monitor III software for instructions. See the List of Related Materials for document part numbers.

The system event stack registers 41500–41515 contain the status (active or inactive) of fault warnings and shutdowns, inputs, outputs, and MDEC/ADEC alarms. See Section 4.5.6.

The event history registers 40871–41270 contain the time and date information for the last 100 events. See Section 4.5.6 for event message codes.

4.5.1 Guide to the Register Map

Description	Registers
Monitoring	40001–40083
Electrical Output	40001–40032
Engine Status	40033–40060
Analog Input Status	40061–40076
Digital Input Status	40077–40078
Controller Status	40079–40083
Maintenance	40084–40112
Time/Date	40113–40115
Time Delay Settings	40116–40124
Settings and Setpoints	40125–40146
Factory Setup	40147–40226
Digital Input Setup	40227–40499
Analog Input Setup	40500–40739
Remapped Registers *	40740–40837
Relay Driver Output Status (see Section 4.5.4)	40838–40839
Relay Driver Output Setup	40840–40870
Event History	40871–41270
Customer-Defined Character Strings	41271–41295
Reserved and Write-Only Registers	41296–41305
Remote Functions	41306–41413
Reserved for Factory Use	41314–41499
System Event Stack (status of fault warnings and shutdowns, inputs, outputs, and MDEC alarms; see Section 4.5.6.)	41500–41515
Reserved for Wireless Monitor	41516–41536
Reserved	41537–41549
Defined Common Faults (Define/Inspect)	41550–41805
Reserved	41806–49998
Device ID	49999
* Registers 40740–40837 have been mapped to 41550–41647 (Defined Common Faults) for compatibility with earlier versions. See Section 4.5.3.	

4.5.2 Modbus Registers

Register	Data Description	Access	Data Type	Range/Units/Notes
40001	L1 - L2 Voltage	RO	WORD	Volts AC
40002	L2 - L3 Voltage	RO	WORD	Volts AC
40003	L3 - L1 Voltage	RO	WORD	Volts AC
40004	L1 - L0 Voltage	RO	WORD	Volts AC
40005	L2 - L0 Voltage	RO	WORD	Volts AC
40006	L3 - L0 Voltage	RO	WORD	Volts AC
40007	L1 Current	RO	WORD	Amps AC
40008	L2 Current	RO	WORD	Amps AC
40009	L3 Current	RO	WORD	Amps AC
40010	Frequency	RO	WORD	Hz X 100
40011	Total kW	RO	WORD	kW
40012	Percent of Rated kW	RO	WORD	% Rated kW
40013	Total Power Factor	RO	SWORD	PF X 100 (SIGNED)
40014	L1 kW	RO	WORD	kW
40015	L1 Power Factor	RO	SWORD	PF X 100 (SIGNED)
40016	L2 kW	RO	WORD	kW
40017	L2 Power Factor	RO	SWORD	PF X 100 (SIGNED)
40018	L3 kW	RO	WORD	kW
40019	L3 Power Factor	RO	SWORD	PF X 100 (SIGNED)
40020	Total kVAR	RO	SWORD	kVAR (SIGNED)
40021	L1 kVAR	RO	SWORD	kVAR (SIGNED)
40022	L2 kVAR	RO	SWORD	kVAR (SIGNED)
40023	L3 kVAR	RO	SWORD	kVAR (SIGNED)
40024	Total kVA	RO	WORD	kVA
40025	L1 kVA	RO	WORD	kVA
40026	L2 kVA	RO	WORD	kVA
40027	L3 kVA	RO	WORD	kVA
40028	Current Lead/Lag	RO	WORD	Bits 0-1 Total Current - Leading = 10 Lagging = 01 Bits 2-3 L1 Current - Leading = 10 Lagging = 01 Bits 4-5 L2 Current - Leading = 10 Lagging = 01 Bits 6-7 L3 Current - Leading = 10 Lagging = 01
40029	Reserved For Future Use	RO	WORD	Returns 0 (zero)
40030	Reserved For Future Use	RO	WORD	Returns 0 (zero)
40031	Reserved For Future Use	RO	WORD	Returns 0 (zero)
40032	Reserved For Future Use	RO	WORD	Returns 0 (zero)
40033	Oil Pressure*	RO	WORD	kPa/psi
40034	Coolant Temperature*	RO	SWORD	Degrees C/Degrees F
40035	Engine Speed*	RO	WORD	RPM
40036	Local Battery Voltage*	RO	WORD	Volts DC X 10
40037	Fuel Pressure*	RO	WORD	kPa/psi DDEC/MDEC/ADEC only
40038	Fuel Temperature*	RO	SWORD	Degrees C/Degrees F DDEC/MDEC/ADEC only
40039	Fuel Rate*	RO	WORD	Liters/Hour X 100 or Gallons/Hour X 100 DDEC only
40040	Used Last Run*	RO	WORD	Liters/Gallons DDEC only
40041	Coolant Pressure*	RO	WORD	kPa/psi DDEC only
40042	Coolant Level*	RO	WORD	% X 10 DDEC only
40043	Lube Oil Temperature*	RO	SWORD	Degrees C/Degrees F DDEC/MDEC/ADEC/Waukesha only
40044	Oil Level*	RO	WORD	% X 10 DDEC only
40045	Crankcase Pressure*	RO	WORD	kPa/psi DDEC only
40046	Ambient Temperature *	RO	SWORD	Degrees C/Degrees F DDEC only
40047	ECM Battery Voltage*	RO	WORD	Volts DC X 10 DDEC/MDEC/ADEC only

*0x7FD6 = data unavailable. 0x7FFF = data is out of range.

Register	Data Description	Access	Data Type	Range/Units/Notes
40048	ECM Status	RO	WORD	0 = DDEC-Equipped, 1 = Non-ECM, 2 = MDEC/ADEC-Equipped
40049	Intake Air Temperature	RO	SWORD	Degrees C/Degrees F MDEC/ADEC/Waukesha only
40050	Intake Air Pressure	RO	WORD	Degrees C/Degrees F MDEC/ADEC only
40051	MDEC/ADEC Fault Codes	RO	WORD	Numeric Fault Code MDEC/ADEC only
40052	Reserved For Future Use	RO	WORD	Returns 0 (zero)
40053	Reserved For Future Use	RO	WORD	Returns 0 (zero)
40054	Reserved For Future Use	RO	WORD	Mapped to register 41500 for compatibility with earlier controller application code versions. Note: Code versions 2.10 and higher use more registers for the Event Stack than previous versions.
40055	Reserved For Future Use	RO	WORD	Returns 0 (zero)
40056	Reserved For Future Use	RO	WORD	Returns 0 (zero)
40057	Reserved For Future Use	RO	WORD	Returns 0 (zero)
40058	Reserved For Future Use	RO	WORD	Returns 0 (zero)
40059	Reserved For Future Use	RO	WORD	Returns 0 (zero)
40060	Reserved For Future Use	RO	WORD	Returns 0 (zero)
40061	Analog Input 00 (Battery Voltage)*	RO	WORD	Volts DC
40062	Analog Input 01*	RO	WORD	User-defined and calibrated through the 550 controller. See the controller operation manual.
40063	Analog Input 02*	RO	WORD	
40064	Analog Input 03*	RO	WORD	
40065	Analog Input 04*	RO	WORD	
40066	Analog Input 05*	RO	WORD	
40067	Analog Input 06*	RO	WORD	
40068	Analog Input 07*	RO	WORD	
40069	Reserved For Additional Input	RO	WORD	
40070	Reserved For Additional Input	RO	WORD	
40071	Reserved For Additional Input	RO	WORD	
40072	Reserved For Additional Input	RO	WORD	
40073	Reserved For Additional Input	RO	WORD	
40074	Reserved For Additional Input	RO	WORD	
40075	Reserved For Additional Input	RO	WORD	
40076	Reserved For Additional Input	RO	WORD	
40077-40078	Digital Input Status/Option Flags	RO	2 WORDS	Word #1 Digital Inputs 0-15: Bit 0 Remote start contacts Bit 1 Emergency stop Bit 2 Low coolant level Bit 3 Digital Input #1 Bit 4 Digital Input #2 Bit 5 Digital Input #3 Bit 6 Digital Input #4 Bit 7 Digital Input #5 Bit 8 Digital Input #6 Bit 9 Digital Input #7 Bit 10 Digital Input #8 Bit 11 Digital Input #9 Bit 12 Digital Input #10 Bit 13 Digital Input #11 Bit 14 Digital Input #12 Bit 15 Digital Input #13

*0x7FD6 = data unavailable. 0x7FFF = data is out of range.

Register	Data Description	Access	Data Type	Range/Units/Notes
40077-40078, cont.	Digital Input Status/Option Flags	RO	2 WORDS	Word #2: Bit 0 Digital Input #14 Bit 1 Digital Input #15 Bit 2 Digital Input #16 Bit 3 Digital Input #17 Bit 4 Digital Input #18 Bit 5 Digital Input #19 Bit 6 Digital Input #20 Bit 7 Digital Input #21 Bit 8 DDEC Flag Bit 9 MDEC/ADEC Flag Bit 10 Tier1 Flag Bit 11 Waukesha Flag Bits 12-15 Unused Input is high/option enabled if bit is set. Digital inputs are user-defined through the controller or Monitor III software. See the related operation manual.
40079	Master Switch Position	RO	WORD	0 = Error, 1 = Auto, 2 = Off, 3 = Run
40080	Programming Mode Status	RO	WORD	1 = Off, 2 = Local, 3 = Remote
40081	Reserved For Future Use	RO	WORD	Returns 0 (zero)
40082	Reserved For Future Use	RO	WORD	Returns 0 (zero)
40083	Reserved For Future Use	RO	WORD	Returns 0 (zero)
40084	Total Number of Starts	RO	WORD	Starts
40085	Total Run Time Hrs	RO	LONG	HRS X 100 (LSW FIRST)
40087	Total Run Time Loaded Hrs	RO	LONG	HRS X 100 (LSW FIRST)
40089	Total Run Time Unloaded Hrs	RO	LONG	HRS X 100 (LSW FIRST)
40091	Total Run Time kW Hrs	RO	LONG	kW Hrs (LSW First)
40093	RTSM Total Hrs	RO	LONG	HRS X 100 (LSW FIRST)
40095	RTSM Loaded Hrs	RO	LONG	HRS X 100 (LSW FIRST)
40097	RTSM Unloaded Hrs	RO	LONG	HRS X 100 (LSW FIRST)
40099	RTSM kW Hrs	RO	LONG	kW Hrs (LSW FIRST)
40101	Last Maintenance Date	RO	2 WORDS	Day Month - Year
40103	Operating Days Since Maint.	RO	WORD	Days
40104	Number of Starts Since Maint.	RO	WORD	Starts
40105	Last Start Date	RO	2 WORDS	Day Month - Year
40107	Last Start Time	RO	WORD	Hr Min
40108	Last Run Length	RO	WORD	Hrs X 100
40109	Last Run Loaded	RO	WORD	0 = Unloaded, 1 = Loaded
40110	Timed Run Time (Hr:Min)	RW	WORD	Hr Min
40111	Timed Run Remaining (Hr:Min)	RO	WORD	Hr Min
40112	Is Timed Run Active	RO	WORD	1 = True, 0 = False
40113	Current Date	RW	2 WORDS	Day Month - 2 Digit Year Day of Week (0=Sunday)
40115	Current Time (24 Hr Clock)	RW	WORD (Hr Min)	Hr Min
40116	Time Delay Engine Start	RW	WORD	Min Sec
40117	Time Delay Starting Aid	RW	WORD	Min Sec
40118	Time Delay Crank On	RW	WORD	Min Sec
40119	Time Delay Crank Pause	RW	WORD	Min Sec
40120	Time Delay Engine Cooldown	RW	WORD	Min Sec
40121	Time Delay Crank Cycles	RW	WORD	Cycles
40122	Time Delay Overvoltage	RW	WORD	Min Sec
40123	Time Delay Undervoltage	RW	WORD	Min Sec
40124	Time Delay Load Shed kW	RW	WORD	Min Sec

*0x7FD6 = data unavailable. 0x7FFF = data is out of range.

Register	Data Description	Access	Data Type	Range/Units/Notes	
40125	Operating Mode	RW	WORD	Bits 0-1: Operating Mode 1=Standby, 2=Prime Power Bit 2: Unused Bit 3: MDEC/ADEC DSC Mode 1 = Enabled, 0 = Disabled Bit 4: MDEC/ADEC VSG Mode 1 =Enabled, 0 = Disabled Bits 5-7: Temp Sensor Type	
40126	System Voltage	RW	WORD	Volts AC	
40127	System Frequency	RW	WORD	Hz	
40128	System Phase	RW	WORD	1 = 3 Phase Delta, 2 = 3 Phase Wye, 3 = Single Phase	
40129	kW Rating	RW	WORD	kW	
40130	Load Shed Output	RW	WORD	% of kW RATING	
40131	Overvoltage	RW	WORD	% of System Voltage	
40132	Undervoltage	RW	WORD	% of System Voltage	
40133	Overfrequency	RW	WORD	% of System Frequency	
40134	Underfrequency	RW	WORD	% of System Frequency	
40135	Overspeed	RW	WORD	Hz	
40136	Battery Voltage	RW	WORD	Volts DC X 10	
40137	Lo Battery Voltage	RW	WORD	Volts DC X 10	
40138	Hi Battery Voltage	RW	WORD	Volts DC X 10	
40139	Metric Units	RW	WORD	1 = True, 0 = False	
40140	NFPA 110 Defaults Enabled	RW	WORD	1 = True, 0 = False	
40141	Rated Current	RO	WORD	Amps AC	
40142	Cooldown Temperature Override	RW	WORD	1 = True, 0 = False	
40143	Reserved For Future Use	RO	WORD	Returns 0 (zero)	
40144	Reserved For Future Use	RO	WORD	Returns 0 (zero)	
40145	Reserved For Future Use	RO	WORD	Returns 0 (zero)	
40146	Reserved For Future Use	RO	WORD	Returns 0 (zero)	
40147	Final Assembly Date	RO	2 WORDS	Day Month - Year	
40149	Final Assembly Clock No.	RO	LONG	99999 Max (LSW FIRST)	
40151	Total Operating Days	RO	WORD	Days	
40152	Model No.	RO	13 WORDS	26 Character String	
40165	Spec. No.	RO	8 WORDS	16 Character String	
40173	Genset Serial No.	RO	10 WORDS	20 Character String	
40183	Alternator Part No.	RO	10 WORDS	20 Character String	
40193	Engine Part No.	RO	10 WORDS	20 Character String	
40203	Control No.	RO	LONG	(LSW FIRST)	
40205	Code Version	RO	3 WORDS	6 Character String	
40208	Setup Lock	RO	WORD	1 = Locked, 0 = Unlocked	
40209	Engine Model No.	RO	4 WORDS	8 Character String	ECM only
40213	Engine Serial No.	RO	5 WORDS	10 Character String	ECM only
40218	Unit No.	RO	5 WORDS	10 Character String	ECM only
40223	ECM Serial No.	RO	4 WORDS	8 Character String	ECM only

*0x7FD6 = data unavailable. 0x7FFF = data is out of range.

Register	Data Description	Access	Data Type	Range/Units/Notes
Digital Inputs 1-21 Setup (for status see 40077-40079):				
40227	Digital Input 01	RW	13 WORDS PER INPUT	Word 1: Enabled Function ID Word 2: Inhibit Time (Min Sec) Word 3: Delay Time (Min Sec) Word 4-13: 10 Words for 20 Character Description String Refer to Section 4.5.7, Digital Auxiliary Input Functions, for descriptions and codes. See the controller operation manual, TP-6200, for factory-reserved and user-selectable inputs for various applications.
40240	Digital Input 02			
40253	Digital Input 03			
40266	Digital Input 04			
40279	Digital Input 05			
40292	Digital Input 06			
40305	Digital Input 07			
40318	Digital Input 08			
40331	Digital Input 09			
40344	Digital Input 10			
40357	Digital Input 11			
40370	Digital Input 12			
40383	Digital Input 13			
40396	Digital Input 14			
40409	Digital Input 15			
40422	Digital Input 16			
40435	Digital Input 17			
40448	Digital Input 18			
40461	Digital Input 19			
40474	Digital Input 20			
40487	Digital Input 21			
Note: Cannot read past end of block				
Analog Input Setup (for status see registers 40061-40068)				
40500	Analog Input 01	RW	16 WORDS PER INPUT	Refer to the controller operation manual, TP-6200, for identification of user inputs and factory-reserved inputs for specific applications. Word 1: Warning/Shutdown Enable [Bits 8,9] Inhibit Time (Sec) Word 2: Warning Time (Sec) Shutdown Time (Sec) Word 3: Lower Warning Limit Word 4: Upper Warning Limit Word 5: Lower Shutdown Limit Word 6: Upper Shutdown Limit Word 7-16: Analog voltage adjust for switchgear applications only; 10 words for 20 character description string
40516	Analog Input 02			
40532	Analog Input 03			
40548	Analog Input 04			
40564	Analog Input 05			
40580	Analog Input 06			
40596	Analog Input 07			
Note: Cannot read past end of block				
Analog Inputs 8-15 Setup				
40612	Reserved For Non-ECM	RO	16 WORDS PER INPUT	
40628				
40644				
40660				
40676				
40692				
40708				
40724				
Note: Cannot read past end of block				
40740-40837	Mapped to 41550-41647			
*0x7FD6 = data unavailable. 0x7FFF = data is out of range.				

Register	Data Description	Access	Data Type	Range/Units/Notes
Define/Inspect RDO Status (2 WORDS). See Section 4.5.4.				
40838	RDO Status: RDO1 - RDO16	RO*	WORD	Output Is High If Individual Bit Is Set. Bit 0 = RDO 1
40839	RDO Status: RDO17 - RDO31	RO*	WORD	Output Is High If Individual Bit Is Set. Bit 0 = RDO 17
Note: Cannot read past end of block				
* Software-controlled RDOs are RW.				
Define/Inspect RDOs (RW, 1 WORD per RDO). See Section 4.5.6				
40840	Relay Driver Output 01	RW	WORD	Selection Setpoint
40841	Relay Driver Output 02	RW	WORD	Function uses the event codes in Section 4.5.6. Setpoints are for analog inputs only; otherwise setpoint=0.
40842	Relay Driver Output 03	RW	WORD	
40843	Relay Driver Output 04	RW	WORD	
40844	Relay Driver Output 05	RW	WORD	
40845	Relay Driver Output 06	RW	WORD	
40846	Relay Driver Output 07	RW	WORD	
40847	Relay Driver Output 08	RW	WORD	
40848	Relay Driver Output 09	RW	WORD	
40849	Relay Driver Output 10	RW	WORD	
40850	Relay Driver Output 11	RW	WORD	
40851	Relay Driver Output 12	RW	WORD	
40852	Relay Driver Output 13	RW	WORD	
40853	Relay Driver Output 14	RW	WORD	
40854	Relay Driver Output 15	RW	WORD	
40855	Relay Driver Output 16	RW	WORD	
40856	Relay Driver Output 17	RW	WORD	
40857	Relay Driver Output 18	RW	WORD	
40858	Relay Driver Output 19	RW	WORD	
40859	Relay Driver Output 20	RW	WORD	
40860	Relay Driver Output 21	RW	WORD	
40861	Relay Driver Output 22	RW	WORD	
40862	Relay Driver Output 23	RW	WORD	
40863	Relay Driver Output 24	RW	WORD	
40864	Relay Driver Output 25	RW	WORD	Function Setpoint
40865	Relay Driver Output 26	RW	WORD	Function uses the event codes in Section 4.5.6. Setpoints are for analog inputs only; otherwise setpoint=0.
40866	Relay Driver Output 27	RW	WORD	
40867	Relay Driver Output 28	RW	WORD	
40868	Relay Driver Output 29	RW	WORD	
40869	Relay Driver Output 30	RW	WORD	
40870	Relay Driver Output 31	RW	WORD	
Note: Cannot read past end of block				
*0x7FD6 = data unavailable. 0x7FFF = data is out of range.				

Register	Data Description	Access	Data Type	Range/Units/Notes
Event History. See Section 4.5.6 for event codes.				
40871-40910	Event History - Page 1 (1-10)	RO	40 WORDS	10 events, 4 words each: Event Code Setpoint Hr Min Day Month Year See Section 4.5.6 for event codes. Setpoints are for analog inputs only; otherwise setpoint=0 Note: Message code = 0xFFat end of history
40911-40950	Event History - Page 2 (11-20)	RO	40 WORDS	
40951-40990	Event History - Page 3 (21-30)	RO	40 WORDS	
40991-41030	Event History - Page 4 (31-40)	RO	40 WORDS	
41031-41070	Event History - Page 5 (41-50)	RO	40 WORDS	
41071-41110	Event History - Page 6 (51-60)	RO	40 WORDS	
41111-41150	Event History - Page 7 (61-70)	RO	40 WORDS	
41151-41190	Event History - Page 8 (71-80)	RO	40 WORDS	
41191-41230	Event History - Page 9 (81-90)	RO	40 WORDS	
41231-41270	Event History - Page 10 (91-100)	RO	40 WORDS	
Note: Cannot read past end of block.				
Customer-Defined Character Strings (defined through Monitor software)				
41271	Designation	RW	5 WORDS	9 Character String
41276	Load	RW	10 WORDS	20 Character String
41286	Location	RW	10 WORDS	20 Character String
Note: Cannot read past end of block.				
41296	Reserved for future use	RO	WORD	Returns 0 (zero)
41297	Reserved for future use	RO	WORD	Returns 0 (zero)
41298	Reserved for future use	RO	WORD	Returns 0 (zero)
41299	Reserved for future use	RO	WORD	Returns 0 (zero)
41300	Reserved for future use	RO	WORD	Returns 0 (zero)
41301	Reserved for future use	RO	WORD	Returns 0 (zero)
41302	Reserved for future use	RO	WORD	Returns 0 (zero)
41303	Reserved for future use	RO	WORD	Returns 0 (zero)
41304	Reserved for future use	RO	WORD	Returns 0 (zero)
41305	Reserved for future use	RO	WORD	Returns 0 (zero)
Note: Cannot Read Past End of Block				
Remote Functions				
41306	Start Timed Run	WO	WORD	1 = Start, 0 = No Start
41307	Stop Timed Run	WO	WORD	1 = Stop, 0 = No Stop
41308	Reset Maintenance Records	WO	WORD	1 = Reset, 0 = No Reset
41309	Remote Fault Reset	WO	WORD	1 = Reset, 0 = No Reset
41310	Reserved for future use	RO	WORD	Returns 0 (zero)
41311	Reserved for future use	RO	WORD	Returns 0 (zero)
41312	Reserved for future use	RO	WORD	Returns 0 (zero)
41313	Reserved for future use	RO	WORD	Returns 0 (zero)
41314-41499	Reserved for factory use			
*0x7FD6 = data unavailable. 0x7FFF = data is out of range.				

Register	Data Description	Access	Data Type	Range/Units/Notes
System Event Stack (must be read as 16 register block). See Sections 4.5.5 and 4.5.6.				
41500	System Events 0-15 Word #1	RO	16 WORDS	System event status. 0=not active 1=active Each bit corresponds to a different event code. See Sections 4.5.5 and 4.5.6.
41501	System Events 16-31 Word #2			
41502	System Events 32-47 Word #3			
41503	System Events 48-63 Word #4			
41504	System Events 64-79 Word #5			
41505	System Events 80-95 Word #6			
41506	System Events 96-111 Word #7			
41507	System Events 112-127 Word #8			
41508	System Events 128-143 Word #9			
41509	System Events 144-159 Word #10			
41510	System Events 160-175 Word #11			
41511	System Events 176-191 Word #12			
41512	System Events 192-207 Word #13			
41513	System Events 208-223 Word #14			
41514	System Events 224-239 Word #15			
41515	System Events 240-255 Word #16			
Note: Cannot Read Past End of Block.				
41516-41536	Reserved	RO	WORD	Reserved for the Wireless Monitor
41537-41549	Not used	RO	WORD	Returns illegal address
Define/Inspect Defined Common Faults:				
41550	Emergency Stop	RW	WORD	Selected Setpoint The selected byte indicates whether a given fault has been assigned to the defined common fault: 0=not assigned to the defined common fault; 1=assigned to the defined common fault. The setpoint byte indicates the setpoint value for that item.
41551	Overspeed			
41552	Overcrank			
41553	High Coolant Temperature Shutdown			
41554	Oil Pressure Shutdown			
41555	Low Coolant Temperature Warning (ECM only)			
41556	Low Fuel			
41557	High Coolant Temperature Warning			
41558	Oil Pressure Warning			
41559	Master Not In Auto			
41560	NFPA 110 Fault			
41561	Low Battery Voltage			
41562	High Battery Voltage			
41563	Battery Charger Fault			
41564	System Ready			
41565	Loss of ECM Comm (ECM only)			
41566	No Oil Pressure Signal			
41567	High Oil Temperature Shutdown			
41568	No Coolant Temperature Signal			
41569	Low Coolant Level			
41570	Speed Sensor Fault			
41571	Locked Rotor			
*0x7FD6 = data unavailable. 0x7FFF = data is out of range.				

Register	Data Description	Access	Data Type	Range/Units/Notes
Define/Inspect Defined Common Faults, continued:				
41572	Master Switch Error	RW	WORD	Selected Setpoint The selected byte indicates whether a given fault has been assigned to the defined common fault: 0=not assigned to the defined common fault; 1=assigned to the defined common fault. The setpoint byte indicates the setpoint value for that item.
41573	Master Switch Open			
41574	Master Switch Off			
41575	AC Sensing Loss			
41576	Over Voltage			
41577	Under Voltage			
41578	Weak Battery			
41579	Over Frequency			
41580	Under Frequency			
41581	Load Shed kW Overload	RW	WORD	Selected Setpoint
41582	Load Shed kW Under Frequency			
41583	Over Current Warning			
41584	EPS Supplying Load			
41585	Internal Fault			
41586	Engine Cooldown Delay			
41587	Engine Start Delay			
41588	Starting Aid			
41589	Generator Running			
41590	Air Damper Control			
41591	Ground Fault	RW	WORD	Selected Setpoint
41592	EEPROM Write Failure			
41593	Critical Overvoltage			
41594	Alternator Protect Shutdown			
41595	Air Damper Indicator			
41596	Digital Input 01	RW	WORD	Note: Analog and digital inputs are user-defined through the controller or Monitor III software. See the related operation manual.
41597	Digital Input 02			
41598	Digital Input 03			
41599	Digital Input 04			
41600	Digital Input 05			
41601	Digital Input 06			
41602	Digital Input 07			
41603	Digital Input 08			
41604	Digital Input 09			
41605	Digital Input 10			
41606	Digital Input 11			
41607	Digital Input 12			
41608	Digital Input 13			
41609	Digital Input 14			
41610	Digital Input 15			
41611	Digital Input 16			
41612	Digital Input 17			
41613	Digital Input 18			
41614	Digital Input 19			
41615	Digital Input 20			
41616	Digital Input 21	RW	WORD	Note: Analog and digital inputs are user-defined through the controller or Monitor III software. See the related operation manual.
41617	Analog Input 01			
41618	Analog Input 02			
41619	Analog Input 03			
41620	Analog Input 04			

*0x7FD6 = data unavailable. 0x7FFF = data is out of range.

Register	Data Description	Access	Data Type	Range/Units/Notes
41621	Analog Input 05	RW	WORD	Note: Analog and digital inputs are user-defined through the controller or Monitor III software. See the related operation manual.
41622	Analog Input 06			
41623	Analog Input 07			
41624	Reserved for additional input	RW	WORD	
41625	Reserved for additional input			
41626	Reserved for additional input			
41627	Reserved for additional input			
41628	Reserved for additional input			
41629	Reserved for additional input			
41630	Reserved for additional input			
41631	Reserved for additional input			
41632	Defined Common Fault			
41633	Software Controlled RDO#1			
41634	Software Controlled RDO#2			
41635	Software Controlled RDO#3			
41636	Software Controlled RDO#4			
41637-41648	<i>Reserved for factory use</i>			<i>Reserved for factory use</i>
41649	Genset Parameter Warning	RW	WORD	Selected Setpoint
41650	Genset S/N Mismatch Warning			
41651	Genset S/N Mismatch Shutdown			
41652	<i>Reserved for factory use</i>			
41653	Protective Relay Overvoltage	RW	WORD	Switchgear applications only. Cannot be defined as common fault or assigned as RDO, but can be referenced in event stack/log.
41654	Protective Relay Under Voltage			
41655	Protective Relay Overfrequency			
41656	Protective Relay Underfrequency			
41657	Protective Relay Reverse Power			
41658	Protective Relay Over Power			
41659	Protective Relay Loss of Field			
41660	Protective Relay Overcurrent Vr			
41661	Reverse Power Shutdown	RW	WORD	Switchgear applications only
41662	Over Power Shutdown			
41663	Loss of Field Shutdown			
41664	Over Current Shutdown			
41665	Common Protective Relay Output	RW	WORD	Switchgear applications only. Cannot be defined as common fault, but can be assigned as RDO and referenced in event stack/log.
41666	In Synch	RW	WORD	Switchgear applications only.
41667	Breaker Trip			
41668	Fuel Valve Relay	RW	WORD	Waukesha only.
41669	Pre Lube Relay			
41670	Air -Fuel Module Start			
41671	Oil Temperature Loss of Signal			
41672	High Oil Temperature Warning			
41673	Intake Air Temperature Loss of Signal			
41674	High Intake Air Temperature Warning			
41675	High Intake Air Temperature Shutdown			

*0x7FD6 = data unavailable. 0x7FFF = data is out of range.

Register	Data Description	Access	Data Type	Range/Units/Notes	
41676	MDEC/ADEC Yellow Alarm	RW	WORD	MDEC/ADEC only.	
41677	MDEC/ADEC Red Alarm				
41678	MDEC/ADEC Block Heater Control				
41679	Low Coolant Temperature Shutdown				
41680	MDEC/ADEC Load Shed Over Temperature				
41681	Maintenance Reminder	RW	WORD		
41682	Engine Derate Active (ECM only)	RW	WORD		
41683	Engine Stalled	RW	WORD		
41684	J1939 CAN Engine Shutdown	RW	WORD	Deere, Doosan, GM engines only	
41685-41724	Reserved For Future Use	RW	WORD		
41725	Loss of Oil Pressure Signal #1	RO	WORD	Active only with Marine third-party approval option (Lloyd's option)	
41726	Loss of Oil Pressure Signal #2	RO	WORD		
41727	Loss of Coolant Temp Signal #1	RO	WORD		
41728	Loss of Coolant Temp Signal #2	RO	WORD		
41729	High Coolant Temp Shutdown #1	RO	WORD		
41730	High Coolant Temp Shutdown #2	RO	WORD		
41731	Low Oil Pressure Shutdown #1	RO	WORD		
41732	Low Oil Pressure Shutdown #2	RO	WORD		
41733	High Coolant Temp Warning #1	RO	WORD		
41734	High Coolant Temp Warning #2	RO	WORD		
41735	Low Coolant Temp Warning #1	RO	WORD		
41736	Low Coolant Temp Warning #2	RO	WORD		
41737	Low Oil Pressure Warning #1	RO	WORD		
41738	Low Oil Pressure Warning #2	RO	WORD		
41739	Low Coolant Pressure Warning	RO	WORD		
41740	Loss of Signal Coolant Pressure	RO	WORD		
41741	Air -Fuel Module Start	RW	WORD		Waukesha only.
41742	No Dial Tone	RW	WORD		With optional dial-out feature only.
41743	Dialout Message Sent	RW	WORD		
41744	No Modem at Powerup	RW	WORD		
41745	Modem Connection Failed	RW	WORD		
41746-41791	Reserved For Future Use	RW	WORD		
41792	Dual Start Application	RW	WORD		
41793	Starter A Failure	RW	WORD		
41794	Starter B Failure	RW	WORD		
41795	Dual Starter B	RW	WORD		
41796	Controller Setup Warning	RW	WORD		
41797	Phase Selection Error	RW	WORD		
41798	Voltage Selection Error	RW	WORD		
41799	Frequency Selection Error	RW	WORD		
41800	kW Selection Error	RW	WORD		
41801	EEPROM Block Initialized	RW	WORD		
41802	Date Changed	RW	WORD		
41803	Controller Initialized	RW	WORD		
41804-49998	Reserved For Future Use	RW	WORD		
Device ID					
49999	Device ID	RO	WORD	Dec 550 Device ID = 20	
*0x7FD6 = data unavailable. 0x7FFF = data is out of range.					

4.5.3 Remapped Registers

Registers 40740–40837 have been mapped to 41550–41647 (defined common faults) for compatibility with earlier code versions.

Register	Mapped to:	Description
40740	41550	Emergency Stop
40741	41551	Overspeed
40742	41552	Overcrank
40743	41553	High Coolant Temperature Shutdown
40744	41554	Oil Pressure Shutdown
40745	41555	Low Coolant Temperature Warn.
40746	41556	Low Fuel
40747	41557	High Coolant Temperature Warning
40748	41558	Oil Pressure Warning
40749	41559	Master Not In Auto
40750	41560	NFPA 110 Fault
40751	41561	Low Battery Voltage
40752	41562	High Battery Voltage
40753	41563	Battery Charger Fault
40754	41564	System Ready
40755	41565	Loss of ECM Comm
40756	41566	No Oil Pressure Signal
40757	41567	High Oil Temperature Shutdown
40758	41568	No Coolant Temperature Signal
40759	41569	Low Coolant Level
40760	41570	Speed Sensor Fault
40761	41571	Locked Rotor
40762	41572	Master Switch Error
40763	41573	Master Switch Open
40764	41574	Master Switch Off
40765	41575	AC Sensing Loss
40766	41576	Over Voltage
40767	41577	Under Voltage
40768	41578	Weak Battery
40769	41579	Over Frequency
40770	41580	Under Frequency
40771	41581	Load Shed kW Overload
40772	41582	Load Shed kW Under Frequency
40773	41583	Over Current Warning
40774	41584	EPS Supplying Load
40775	41585	Internal Fault
40776	41586	Engine Cooldown Delay
40777	41587	Engine Start Delay
40778	41588	Starting Aid
40779	41589	Generator Running
40780	41590	Air Damper Control
40781	41591	Ground Fault
40782	41592	EEPROM Write Failure
40783	41593	Critical Overvoltage
40784	41594	Alternator Protect Shutdown
40785	41595	Air Damper Indicator

Register	Mapped to:	Description
40786	41596	Digital Input 01
40787	41597	Digital Input 02
40788	41598	Digital Input 03
40789	41599	Digital Input 04
40790	41600	Digital Input 05
40791	41601	Digital Input 06
40792	41602	Digital Input 07
40793	41603	Digital Input 08
40794	41604	Digital Input 09
40795	41605	Digital Input 10
40796	41606	Digital Input 11
40797	41607	Digital Input 12
40798	41608	Digital Input 13
40799	41609	Digital Input 14
40800	41610	Digital Input 15
40801	41611	Digital Input 16
40802	41612	Digital Input 17
40803	41613	Digital Input 18
40804	41614	Digital Input 19
40805	41615	Digital Input 20
40806	41616	Digital Input 21
40807	41617	Analog Input 01
40808	41618	Analog Input 02
40809	41619	Analog Input 03
40810	41620	Analog Input 04
40811	41621	Analog Input 05
40812	41622	Analog Input 06
40813	41623	Analog Input 07
40814	41624	<i>Reserved for additional input</i>
40815	41625	
40816	41626	
40817	41627	
40818	41628	
40819	41629	
40820	41630	
40821	41631	
40822	41632	Defined Common Fault
40823	41633	Software Controlled RDO#1
40824	41634	Software Controlled RDO#2
40825	41635	Software Controlled RDO#3
40826	41636	Software Controlled RDO#4
40827	41637	<i>Reserved for factory use</i>
40828	41638	
40829	41639	
40830	41640	
40831	41641	
40832	41642	
40833	41643	
40834	41644	
40835	41645	
40836	41646	
40837	41647	

4.5.4 Relay Driver Outputs

Status. Registers 40838–40839 contain the status (active or not active) of the relay driver outputs (RDOs). Each register is a 16-bit word and each individual bit corresponds to one RDO. Figure 4-8 illustrates how the RDO status codes are stored.

The RDO is active if the corresponding bit is set (equal to 1). The example in Figure 4-7 shows that RDOs 7, 8, 12, 18, 23, and 30 are active.

To identify the functions assigned to the RDOs, check registers 40840–40870.

Setup. Registers 40840–40870 contain the RDO function and setpoint information. The function assigned to the RDO is indicated by the event codes shown in the first byte of the register. Event codes are listed in the table in Section 4.5.6. Setpoints are for analog inputs only; otherwise setpoint=0.

Register	RDO Number Corresponding to Each Bit															
40848	16	15	14	13	12	11	10	9	8	7	6	5	4	3	2	1
40849	—	31	30	29	28	27	26	25	24	23	22	21	20	19	18	17

Figure 4-6 RDO Status Registers

Register	RDO Status: 0 = Not Set (not active), 1 = Set (active)															
40848	0	0	0	0	1	0	0	0	1	1	0	0	0	0	0	0
40849	—	0	1	0	0	0	0	0	0	1	0	0	0	0	1	0

Figure 4-7 RDO Status Example

4.5.5 System Event Codes

Event codes are contained in registers 41500 through 41515. Each register is a 16-bit word, and each bit corresponds to a system event code. Figure 4-8 illustrates how the event codes are stored in the system event stack registers. The numbers 0–255 in Figure 4-8 correspond to the event codes shown in the System Event Codes table, Section 4.5.6. For example, number 6 corresponds to low fuel.

The condition indicated by the message code is active if the corresponding bit is set. Figure 4-9 shows register 41500 indicating low battery voltage, a high coolant temperature warning, and a low fuel condition.

Register	Event Code Indicated by Each Bit (See Section 4.5.6 for event code identification.)															
41500	15	14	13	12	11	10	9	8	7	6	5	4	3	2	1	0
41501	31	30	29	28	27	26	25	24	23	22	21	20	19	18	17	16
41502	47	46	45	44	43	42	41	40	39	38	37	36	35	34	33	32
41503	63	62	61	60	59	58	57	56	55	54	53	52	51	50	49	48
41504	79	78	77	76	75	74	73	72	71	70	69	68	67	66	65	64
41505	95	94	93	92	91	90	89	88	87	86	85	84	83	82	81	80
41506	111	110	109	108	107	106	105	104	103	102	101	100	99	98	97	96
41507	127	126	125	124	123	122	121	120	119	118	117	116	115	114	113	112
41508	143	142	141	140	139	138	137	136	135	134	133	132	131	130	129	128
41509	159	158	157	156	155	154	153	152	151	150	149	148	147	146	145	144
41510	175	174	173	172	171	170	169	168	167	166	165	164	163	162	161	160
41511	191	190	189	188	187	186	185	184	183	182	181	180	179	178	177	176
41512	207	206	205	204	203	202	201	200	199	198	197	196	195	194	193	192
41513	223	222	221	220	219	218	217	216	215	214	213	212	211	210	209	208
41514	239	238	237	236	235	234	233	232	231	230	229	228	227	226	225	224
41515	255	254	253	252	251	250	249	248	247	246	245	244	243	242	241	240

Figure 4-8 Event Codes Stored in System Event Stack Registers 41500 through 41515

Register	Event Code Status: 0 = Not Set, 1 = Set															
41500	0	0	0	0	1	0	0	0	1	1	0	0	0	0	0	0

Figure 4-9 Event Code Status Example, Register 41500

4.5.6 System Event Code Table

The system event codes in the following table are used for relay driver output functions as well as for events in the event history and the event stack.

Code	Description
0	Emergency Stop
1	Overspeed
2	Overcrank
3	High Coolant Temperature Shutdown
4	Oil Pressure Shutdown
5	Low Coolant Temperature
6	Low Fuel Warning
7	High Coolant Temperature Warning
8	Oil Pressure Warning
9	Master Not In Auto
10	NFPA 110 Fault
11	Low Battery Voltage
12	High Battery Voltage
13	Battery Charger Fault
14	System Ready
15	Loss of ECM Comm
16	No Oil Pressure Signal
17	High Oil Temperature Shutdown
18	No Coolant Temperature Signal
19	Low Coolant Level
20	Speed Sensor Fault
21	Locked Rotor
22	Master Switch Error
23	Master Switch Open
24	Master Switch Off
25	AC Sensing Loss
26	Over Voltage
27	Under Voltage
28	Weak Battery
29	Over Frequency
30	Under Frequency
31	Load Shed kW Overload
32	Load Shed kW Under Frequency
33	Over Current
34	EPS Supplying Load
35	Internal Fault
36	Engine Cooldown Delay
37	Engine Start Delay
38	Starting Aid
39	Generator Running
40	Air Damper Control
41	Ground Fault
42	EEPROM Write Failure
43	Critical Overvoltage
44	Alternator Protect Shutdown
45	Air Damper Indicator
46	Digital Input 01

Code	Description
47	Digital Input 02
48	Digital Input 03
49	Digital Input 04
50	Digital Input 05
51	Digital Input 06
52	Digital Input 07
53	Digital Input 08
54	Digital Input 09
55	Digital Input 10
56	Digital Input 11
57	Digital Input 12
58	Digital Input 13
59	Digital Input 14
60	Digital Input 15
61	Digital Input 16
62	Digital Input 17
63	Digital Input 18
64	Digital Input 19
65	Digital Input 20
66	Digital Input 21
67	Analog Input 01
68	Analog Input 02
69	Analog Input 03
70	Analog Input 04
71	Analog Input 05
72	Analog Input 06
73	Analog Input 07
74	<i>Reserved for additional input</i>
75	<i>Reserved for additional input</i>
76	<i>Reserved for additional input</i>
77	<i>Reserved for additional input</i>
78	<i>Reserved for additional input</i>
79	<i>Reserved for additional input</i>
80	<i>Reserved for additional input</i>
81	<i>Reserved for additional input</i>
82	Defined Common Fault
83	Software Controlled RDO#1
84	Software Controlled RDO#2
85	Software Controlled RDO#3
86	Software Controlled RDO#4
99	Genset Parameter Warning
100	Genset S/N Mismatch Warning
101	Genset S/N Mismatch Shutdown
103	Protective Relay Overvoltage
104	Protective Relay Under Voltage
105	Protective Relay Overfrequency
106	Protective Relay Underfrequency
107	Protective Relay Reverse Power
108	Protective Relay Over Power
109	Protective Relay Loss of Field
110	Protective Relay Overcurrent Vr
111	Reverse Power Shutdown

Code	Description
112	Over Power Shutdown
113	Loss of Field Shutdown
114	Over Current Shutdown
115	Common Protective Relay Output
116	In Synch
117	Breaker Trip
118	Fuel Valve Relay
119	Pre Lube Relay
120	Air -Fuel Module Start
121	Oil Temperature Loss of Signal
122	High Oil Temperature Warning
123	Intake Air Temperature Loss of Signal
124	High Intake Air Temperature Warning
125	High Intake Air Temperature Shutdown
126	MDEC/ADEC Yellow Alarm
127	MDEC/ADEC Red Alarm
128	MDEC/ADEC Block Heater Control
129	Low Coolant Temperature Shutdown
130	MDEC/ADEC Load Shed Over Temperature
131	<i>Reserved For Future Use</i>
132	Engine Derate Active
133	Engine Stalled
134	J1939 CAN Engine Shutdown
135-174	Reserved for Future Use
175	No Oil Press1 Signal
176	No Oil Press2 Signal
177	No Cool Temp1 Signal
178	No Cool Temp2 Signal
179	Hi Cool Temp1 Shtdwn
180	Hi Cool Temp2 Shtdwn
181	Oil Press1 Shutdown
182	Oil Press2 Shutdown
183	Hi Cool Temp1 Warn
184	Hi Cool Temp2 Warn
185	Lo Cool Temp1 Warn
186	Lo Cool Temp2 Warn
187	Oil Press1 Warning
188	Oil Press2 Warning
189	Coolant Pressr Warn
190	No Cool Press Signal
191	Air -Fuel Module Start
192	No Dial Tone
193	Dialout Message Sent
194	No Modem at Powerup
195	Modem Connection Failed
196	Close Button Acknowledged
197	Open Button Acknowledged
198	Key Switch Locked
199	Key Switch Unlocked

Code	Description
200	Auto Button Acknowledged
201	Off Button Acknowledged
202	Run Button Acknowledged
203	Generator Circuit Breaker Closed
204	Generator Circuit Breaker Open
205	Utility circuit Breaker Closed
206	Utility Circuit Breaker Open
207	Common Warning
208	Common Load Shed
209	PGEN Common Warning
210	PGEN Common Fault
211	PGEN Comm Not Online
212	PGEN Duplicate ID
213	PGEN Missing Node
214	PGEN Extra Node
215	Auto Synch Disabled
216	Volts and Freq OK
217	Synch Frequency matched
218	Synch Phase matched
219	Synch Volts Matched
220	CB Trip to Shutdown Timeout
221	Dead Bus Sense Error
222	First On Fault
223	Fail to Synch Timeout
224	CB Close Fault
225	CB Close Attempts Fault
226	CB Open Fault
227	CB Current Fault
228	CB Common Fault
229	Contactors Output
230	Close Generator Circuit Breaker
231	External Breaker Trip
232	Remote Shutdown
233-241	Reserved for Future Use
242	Dual Starter App
243	Starter A Failure
244	Starter B Failure
245	Dual Starter B
246	Controller Setup Error
247	Phase Selection Error
248	Voltage Selection Error
249	Frequency Selection Error
250	kW Selection Error
251	EEPROM Block Initialized
252	Date Changed
253	Controller Initialized

4.5.7 Digital Auxiliary Input Functions

The following function ID codes are used in registers 40227–40499 to identify the function that is assigned to each digital input. The assignment is done through the controller keypad or Monitor III software. See the operation manual for the 550 controller or Monitor III software.

Function ID	Name	Notes
1	Warning	
2	Shutdown Type A	
3	Shutdown Type B	
4	Voltage Raise	
5	Voltage Lower	
6	VAR PF Mode	
7	Remote Shutdown	
8	Remote Reset	
9	Air Damper	
10	Low Fuel Warning	
11	Field Over Volts	
12	Idle Mode	ECM only
13	Battle Switch	
14	Ground Fault	
15	Bat Chgr Fault	
16	High Oil Temperature	
17	Low Coolant Lvl	
18	Low Coolant Temperature	ECM only (not user-assignable)
19	Breaker Closed	(not user-assignable)
20	Enable Synch	(not user-assignable)
21	AFM Shutdown	Waukesha only (not user-assignable)
22	Knock Shutdown	Waukesha only (not user-assignable)
23	Deton Warning	Waukesha only (not user-assignable)
24	Deton Shutdown	Waukesha only (not user-assignable)
25	Low Fuel Shutdown	(not user-assignable)
26	VSG Disable	

Section 5 Decision-Maker 3000 Generator Set Controller

5.1 Specifications

The Decision-Maker® 3000 controller's Modbus® communication capability:

- Supports industry-standard Modbus® RTU protocol.
- Can use Modbus® TCP protocol with the addition of a Modbus/Ethernet converter.
- Uses RS-485 connections to connect to a Modbus® master singly or over an RS-485 network.
- Connects to an Ethernet network using a Modbus/Ethernet converter.
- Uses standard baud rates of 9600, 19200, 38400, or 57600.

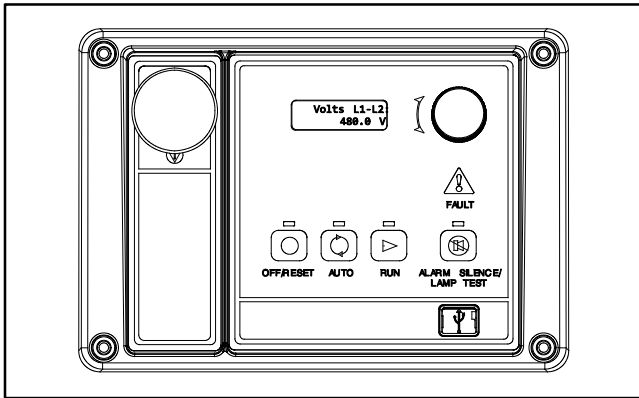
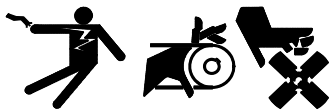

Figure 5-1 Decision-Maker® 3000 Controller

5.2 Hardware Connections

⚠ WARNING



**Accidental starting.
Can cause severe injury or death.**

Disconnect the battery cables before working on the generator set. Remove the negative (-) lead first when disconnecting the battery. Reconnect the negative (-) lead last when reconnecting the battery.

Disabling the generator set. Accidental starting can cause severe injury or death. Before working on the generator set or connected equipment, disable the generator set as follows: (1) Move the generator set master switch to the OFF position. (2) Disconnect the power to the battery charger. (3) Remove the battery cables, negative (-) lead first. Reconnect the negative (-) lead last when reconnecting the battery. Follow these precautions to prevent starting of the generator set by an automatic transfer switch, remote start/stop switch, or engine start command from a remote computer.

Circuit isolation is recommended for installations that may be exposed to electrical noise. See Appendix B, Noise and Wiring Practices.

Use the following procedure to connect the hardware. Observe the safety precautions. Also see the network connection diagrams in TT-1405.

Ethernet connections require the use of a Modbus/Ethernet converter module. See TT-1405 for Modbus/Ethernet converter connection and setup information.

Decision-Maker 3000 Connection Procedure

1. Press the OFF button on the controller.
2. Disconnect the power to the battery charger, if equipped.
3. Disconnect the generator set engine starting battery(ies), negative (-) lead first.
4. Turn off and disconnect the power to all devices in the system.
5. Connect to communication port P21 as shown in Figure 5-2 and Figure 5-3.
6. Verify that the controller is OFF.
7. Reconnect the generator set engine starting battery, negative (-) lead last.
8. Reconnect power to the battery charger, if equipped.

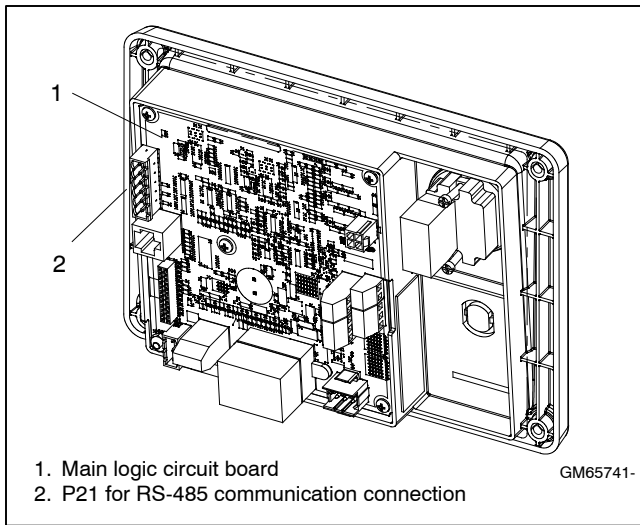

Figure 5-2 Communication Port P21

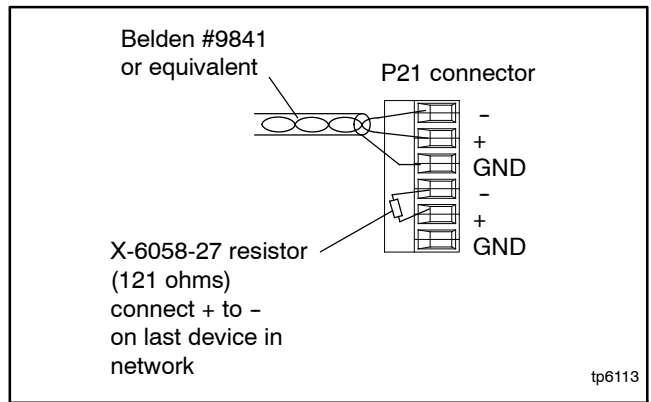

Figure 5-3 Connection Details

5.3 Controller Setup

Use Kohler® SiteTech™ software and a personal computer connected to the controller's USB port to configure the controller's communication parameters shown in Figure 5-4. See TP-6701, SiteTech Software Operation Manual, for instructions.

SiteTech Group	Parameter	Setting
Modbus	Address	Use a unique network address between 1 and 247 for each unit. Use 1 for a single connection. Do not use 0 (zero).
	Baud rate	9600, 19200, 38400, or 57600. Must match the PC and all devices in the system.

Figure 5-4 Decision-Maker 3000 Communication Parameters

5.4 Modbus Registers

This section contains Modbus® registers for the Decision-Maker® 3000 controller. Refer to Section 1.3 for definitions of terms and symbols used in the register tables.

Time delays, setpoints, inputs and outputs, and other user-defined parameters are entered through the controller keypad or SiteTech™ software. Refer to the operation manuals for the controller or software for instructions. See the List of Related Materials for document part numbers.

Register	Parameter	Write Access	Units	Divider	Type/Notes
1000	Vendor	RO			Int16
1001	Product	RO			Int16
1002	FirmwareVersion	RO			Int32
1100	EngineSpeed	RO	RPM	1	Int16
1101	EngineTargetSpeed	RO	RPM	1	Int16
1102	EngineOilPressure	RO	kPa	10	Int16
1103	EngineCoolantTemperature	RO	°C	10	Int16
1104	EngineOilLevel	RO	%	1	Int16
1106	EngineFuelLevel	RO	%	1	Int16
1107	BatteryVoltage	RO	V	10	Int16
1109	FuelTemperature	RO	°C	1	Int16
1110	FuelPressure	RO	kPa	1	Int16
1111	FuelRate	RO	L/h	1	Int16
1112	FuelUsedLastRun	RO	L	10	Int32
1114	CoolantPressure	RO	kPa	1	Int16
1115	LubeOilTemperature	RO	°C	1	Int16
1116	CrankcasePressure	RO	kPa	100	Int16
1117	GensetControllerTemperature	RO	°C	1	Int16
1118	BatteryVoltageFromEcm	RO	V	1	Int16
1119	ExhaustTemperature	RO	°C	10	Int16
1120	ExhaustPressure	RO	kPa	100	Int16
1121	IntakeAirTemperature	RO	°C	1	Int16
1122	IntakeAirPressure	RO	kPa	1	Int16
1123	EngineLowOilPressureSwitch	RO	On/Off	1	Boolean
1124	EngineOilLevelSwitch	RO	On/Off	1	Boolean
1125	EngineHighCoolantTemperatureSwitch	RO	On/Off	1	Boolean
1126	EngineLowCoolantTemperatureSwitch	RO	On/Off	1	Boolean
1127	EngineLowFuelLevelSwitch	RO	On/Off	1	Boolean
1309	GeneratorApparentPowerA	RO	VA	10	Int32
1311	GeneratorApparentPowerB	RO	VA	10	Int32
1313	GeneratorApparentPowerC	RO	VA	10	Int32
1315	GeneratorTotalApparentPower	RO	VA	10	Int32
1325	GeneratorTruePowerA	RO	W	10	Int32
1327	GeneratorTruePowerB	RO	W	10	Int32
1329	GeneratorTruePowerC	RO	W	10	Int32
1331	GeneratorTrueTotalPower	RO	W	10	Int32
1333	GeneratorTruePercentOfRatedPower	RO	%	1	Int16
1334	GeneratorVoltageAB	RO	V	10	Int32
1336	GeneratorVoltageBC	RO	V	10	Int32

* Locked personality profile parameter. Can only be changed by loading a new personality profile.
† Parameter can be changed only when the engine is not running.

Register	Parameter	Write Access	Units	Divider	Type/Notes
1338	GeneratorVoltageCA	RO	V	10	Int32
1340	GeneratorVoltageAverageLineToLine	RO	V	10	Int32
1342	GeneratorVoltageAN	RO	V	10	Int32
1344	GeneratorVoltageBN	RO	V	10	Int32
1346	GeneratorVoltageCN	RO	V	10	Int32
1348	GeneratorVoltageAverageLineToNeutral	RO	V	10	Int32
1350	GeneratorCurrentA	RO	A	10	Int32
1352	GeneratorCurrentB	RO	A	10	Int32
1354	GeneratorCurrentC	RO	A	10	Int32
1356	GeneratorCurrentAverage	RO	A	10	Int32
1358	GeneratorFrequency	RO	Hz	10	Int16
1359	GeneratorMeteringFirmwareVersion	RO			Int16
1400	GensetModelNumber	RW*			String
1421	GensetSerialNumber	RW*			String
1431	AlternatorPartNumber	RW*			String
1441	GensetControllerSerialNumber	RO			Int32
1443	EnginePartNumber	RW*			String
1453	EngineModelNumber	RW*			String
1457	EngineSerialNumber	RW*			String
1471	GensetState	RO			Int16 0: Off 1: Cranking 2: Crank Pause 3: Idle 4: Running 5: Cooldown 6: Stopping 7: Shutdown 8: Test Loaded 9: TestUnloaded 10: Exer Diagn 11: Exer Loaded 12: Priming: 13: ECM powered 14: Fault Cldn 15: Standby 16: Preheat
1504	GensetControllerTotalOperationTime	RO	h	10	Int32
1506	EngineTotalRunTime	RO	h	10	Int32
1508	EngineTotalRunTimeLoaded	RO	h	10	Int32
1510	EngineTotalNumberOfStarts	RO		1	Int32
1512	GensetTotalEnergy	RO	kW-h	10	Int32
1600	EcmModel	RW*			Int16 0: NotSelected 1: NoECM 14: DDCECM 33: DeereECM 61: VolvoECM 68: ScaniaECM 114: GMECM 115: Doosan 128: MotoTronECM 254: ADECECM 255: VECM

* Locked personality profile parameter. Can only be changed by loading a new personality profile.

† Parameter can be changed only when the engine is not running.

Register	Parameter	Write Access	Units	Divider	Type/Notes
1601	MaximumAlternatorCurrent	RO	A		Int16
1602	EngineNumberOfFlywheelTeeth	RW*			Int16
1603	EngineWarmedUpTemperature	RW*	°C		Int16
1604	EngineCooledDownTemperature	RW*	°C		Int16
1605	EngineCrankDisconnectSpeed	RW*	RPM		Int16
1606	EngineIdleSpeed	RW*	RPM		Int16
1607	EngineRunSpeed	RW*	RPM		Int16
1608	EngineCoolantTemperatureProtectives Enabled	RW			Int16 1: LowWarning 2: Critically Low Warning 4: LowShutdown 8: HighWarning 16: Critically High Warning 32: HighShutdown
1609	EngineCoolantTemperatureSensor	RW*			Int16 0: None 1: FuelLevel 11: Coolant Temperature GM38523 (M18x1.5) / GM10166 (M14x1.5) / GM39458 (1/2 NPT) / 226717 (3/8 NPT) 12: Coolant Temperature GM39601 21: AirTemperature GM28823
1611	EngineHighCoolantTemperatureInhibitDelay	RO	s		Int16
1612	EngineLowCoolantTemperatureWarningDelay	RO	s		Int16
1613	EngineHighCoolantTemperatureWarningDelay	RO	s		Int16
1614	EngineLowCoolantTemperatureShutdown Delay	RO	s		Int16
1615	EngineHighCoolantTemperatureShutdown Delay	RO	s		Int16
1616	EngineLowCoolantTemperatureWarningLimit	RW*	°C	10	Int16
1617	EngineHighCoolantTemperatureWarningLimit	RW*	°C	10	Int16
1619	EngineHighCoolantTemperatureShutdown Limit	RW*	°C	10	Int16
1620	EngineCoolantTemperatureDeadband	RO	°C	10	Int16
1621	PersonalityAlternatorManufacturer	RW*			Int16 0: Marathon 1: Kohler 2: Baylor 3: Kato
1622	PersonalityAlternatorTocTimeConstant	RW*	s		Int16
1623	PersonalityAlternatorNumberOfPoles	RW*			Int16

* Locked personality profile parameter. Can only be changed by loading a new personality profile.
† Parameter can be changed only when the engine is not running.

Register	Parameter	Write Access	Units	Divider	Type
1624	PersonalityAlternatorType	RW*			Int16 0: Old Reconnectable Or Dual 1: Old Fixed Voltage 2: Reconnectable 3: Wye Only 4: Low Delta 5: Any Three Phase Wye Or Delta 6: Single Phase 2 Or 4 Wire Only 7: HighDelta7 8: Dog Leg Or Delta No Wye 9: Dog Leg Or Wye No Delta 10: Dog Leg Only
1625	PersonalityFixedVoltage50Hz	RW*	V		Int16
1626	PersonalityPowerRatingSinglePhase50Hz10 PF	RW*	kW		Int16
1627	PersonalityPowerRatingSinglePhase50Hz8PF	RW*	kW		Int16
1628	PersonalityPowerRatingFixedVolt50Hz	RW*	kW		Int16
1629	PersonalityPowerRating50Hz_220_440	RW*	kW		Int16
1630	PersonalityPowerRating50Hz_208_415	RW*	kW		Int16
1631	PersonalityPowerRating50Hz_200_400	RW*	kW		Int16
1632	PersonalityPowerRating50Hz_190_380	RW*	kW		Int16
1633	PersonalityPowerRating50Hz_173_346	RW*	kW		Int16
1634	PersonalityPowerRating50HzDelta	RW*	kW		Int16
1635	PersonalityFixedVoltage60Hz	RW*	V		Int16
1636	PersonalityPowerRatingSinglePhase60Hz10 PF	RW*	kW		Int16
1637	PersonalityPowerRatingSinglePhase60Hz8PF	RW*	kW		Int16
1638	PersonalityPowerRatingFixedVolt60Hz	RW*	kW		Int16
1639	PersonalityPowerRating60Hz_240_480	RW*	kW		Int16
1640	PersonalityPowerRating60Hz_230_460	RW*	kW		Int16
1641	PersonalityPowerRating60Hz_220_440	RW*	kW		Int16
1642	PersonalityPowerRating60Hz_208_416	RW*	kW		Int16
1643	PersonalityPowerRating60Hz_190_380	RW*	kW		Int16
1644	PersonalityPowerRating60HzDelta	RW*	kW		Int16
1700	GensetSystemVoltage	RW†	V	10	Int32
1702	GensetSystemFrequency	RW†	Hz	10	Frequency Configuration 500 or 600
1703	GensetVoltagePhaseConnection	RW†			Int16 0: SinglePhase 1: SinglePhase Dogleg 2: ThreePhaseWye 3: ThreePhaseDelta
1704	GensetPowerRating	RW*	kW	10	Int32
1706	GensetRatedCurrent	RO	A	10	Int32
1708	GensetSystemBatteryVoltage	RW*	V		BatteryConfiguration 12 or 24

* Locked personality profile parameter. Can only be changed by loading a new personality profile.
† Parameter can be changed only when the engine is not running.

Register	Parameter	Write Access	Units	Divider	Type
1709	PrimePowerApplication	RW*			Int16 0: Standby 1: Prime
1710	CurrentTransformerRatio	RW*			Int16
1711	LocalStartMode	RO			Int16 0: Off 1: Auto 2: Run
1712	MeasurementSystem	RW			Int16 0: English 1: Metric
1713	EcmPower	RW†			Boolean
1714	AlarmSilenceRAllowed	RW			Int16 0: AutoOnly 1: Always
1718	UsingVoltageSelectorSwitch	RW†			Boolean
1800	GensetCalibrationFactorVoltageAB	RO		1000000	Int32
1802	GensetCalibrationFactorVoltageBC	RO		1000000	Int32
1804	GensetCalibrationFactorVoltageCA	RO		1000000	Int32
1806	GensetCalibrationFactorVoltageAN	RO		1000000	Int32
1808	GensetCalibrationFactorVoltageBN	RO		1000000	Int32
1810	GensetCalibrationFactorVoltageCN	RO		1000000	Int32
1812	GensetCalibrationFactorCurrentA	RO		1000000	Int32
1814	GensetCalibrationFactorCurrentB	RO		1000000	Int32
1816	GensetCalibrationFactorCurrentC	RO		1000000	Int32
1900	VoltageRegulatorAverageVoltageAdjustment	RW	V	10	Int32
1902	VoltageRegulatorVoltsPerHertzSlope	RW	%	1	Int16
1903	VoltageRegulatorVoltsPerHertzCutIn Frequency	RW	Hz	10	Int16
1904	VoltageRegulatorGain	RW		1	Int16
1905	VoltageRegulatorStabilityAdjust	RW		1	Int16
1906	VoltageRegulatorFirmwareVersion	RO			Int16
2000	EngineIdleDuration	RW	s	10	Int16
2001	EngineRestartDelay	RW	s		Int16
2002	EngineStartDelay	RW	s		Int16
2003	EngineEcmStartDelay	RW	s		Int16
2004	EngineCoolDownDelay	RW	s		Int16
2006	EngineStartAidDelay	RW	s		Int16
2007	EngineCrankOnDelay	RW	s		Int16
2008	EngineCrankPauseDelay	RW	s		Int16
2009	EngineNumberOfCrankCycles	RW†			Int16
2100	AfterCrankDisconnectFaultInhibitDelay	RO	s		Int16
2101	GensetLowBatteryVoltageWarningDelay	RO	s		Int16
2102	GensetHighBatteryVoltageWarningDelay	RO	s		Int16
2103	GensetLowBatteryVoltageWarningLimit	RW	%		Int16
2104	GensetHighBatteryVoltageWarningLimit	RW	%		Int16
2105	GensetBatteryLowCrankingVoltageWarning Delay	RO	s		Int16
2106	GensetBatteryLowCrankingVoltageWarning Limit	RO	%		Int16
2200	EngineLowCoolantLevelShutdownDelay	RO	s		Int16
2206	EngineRW*RotorShutdownDelay	RW	s		Int16

* Locked personality profile parameter. Can only be changed by loading a new personality profile.

† Parameter can be changed only when the engine is not running.

Register	Parameter	Write Access	Units	Divider	Type
2207	EcmCommunicationLossShutdownDelay	RO	s		Int16
2208	GensetLowEngineSpeedShutdownLimit	RW	%		Int16
2209	GensetHighEngineSpeedShutdownLimit	RW	%		Int16
2300	LossOfACSensingShutdownDelay	RO	s		Int16
2301	GensetLowVoltageShutdownDelay	RW	s		Int16
2302	GensetHighVoltageShutdownDelay	RW	s		Int16
2303	GensetLowVoltageShutdownLimit	RW	%		Int16
2304	GensetHighVoltageShutdownLimit	RW	%		Int16
2305	GensetShortTermLowFrequencyShutdownDelay	RO	s		Int16
2306	GensetLongTermLowFrequencyShutdownDelay	RO	s		Int16
2307	GensetHighFrequencyShutdownDelay	RO	s		Int16
2308	GensetLowFrequencyShutdownLimit	RW	%		Int16
2309	GensetHighFrequencyShutdownLimit	RW	%		Int16
3303	ModbusBaudRate	RW	b/s		Int16 0: None 1: Bps9600 (9600) 2: Bps19200 (19200) 3: Bps38400 (38400) 4: Bps57600 (57600)
3305	ModbusSlaveAddress	RW			Int16
13	ModbusCommandSeed	RO			Int16
17	ModbusCommandHash	RW			Byte[20]
27	ModbusCommand	RW			Int16 0: None 1: Start 2: Stop 13: Reset To Device Defaults 14: Reset Writeable Parameters 101: Test Event Log
8000	DigitalInputPresentSummary	RO			Int16[16]
8016	DigitalOutputPresentSummary	RO			Int16[16]
8032	AnalogInputPresentSummary	RO			Int16[16]
8064	DigitalInputValueSummary	RO			Int16[16]
8080	DigitalOutputValueSummary	RO			Int16[16]
8096	AnalogInputValueSummary	RO			Int32[256]
9999	ModbusProduct	RO			Int16 37 = Decision-Maker 3000
11000-18000 Inputs and Outputs. See Section 5.5.					
31000	ModbusActiveAlertsVersion	RO			Int16
31001	ModbusActiveAlertCount	RO			Int16
31002	ModbusActiveAlerts	RO			DeviceEvent[50] See Section 5.6.
32000	ModbusEventsVersion	RO			Int16
32001	ModbusEventCount	RO			Int16
32002	ModbusEvents	RO			ModbusEvent[100] See Section 5.6.
* Locked personality profile parameter. Can only be changed by loading a new personality profile.					
† Parameter can be changed only when the engine is not running.					

5.5 Inputs and Outputs

Register	Parameter	Write Access	Units	Divider	Type/ Notes
11000	DigitalInput[16][16]				Boolean
+0	Digital Input #1 Value	RO			Boolean
+1	Digital Input #1 Enabled	RW			Boolean
+2	Digital Input #1 Event	RW			DigitalInputEvent See Figure 5-6
+4	Digital Input #1 InhibitDelay	RW	s		Int16
+5	Digital Input #1 Delay	RW	s		Int16
+6	Digital Input #1 SwitchType	RW			Int16 0: Normally open 1: Normally closed
11007	DigitalInput[16][16] Additional digital inputs use the next registers in sequence, with the structure shown above.				
14000	DigitalOutput[16][16]				
+0	Value	RO			Boolean
+1	Event	RW			OutputEvent See Figure 5-6
14002	DigitalOutput[16][16] Additional digital outputs use the next registers in sequence, with the structure shown above.				
17000	AnalogInput[16][16]				
+0	Value	RO		10	Int16
+1	RelativeValue	RO	%	100	Int16
+2	ProtectivesEnabled	RW			AnalogInputProtectives 1: LowWarning 2: CriticallyLow Warning 4: LowShutdown 8: HighWarning 16: CriticallyHigh Warning 32: HighShutdown
+3	Event	RW			AnalogInputEvent See Figure 5-6
+5	Sensor	RW			Sensor
+6	LowProtectiveInhibitDelay	RW	s		Int16
+7	HighProtectiveInhibitDelay	RW	s		Int16
+8	NormalDelay	RW	s		Int16
+9	LowWarningDelay	RW	s		Int16
+10	CriticallyLowWarningDelay	RW	s		Int16
+11	HighWarningDelay	RW	s		Int16
+12	CriticallyHighWarningDelay	RW	s		Int16
+13	LowShutdownDelay	RW	s		Int16
+14	HighShutdownDelay	RW	s		Int16
+15	LowWarningLimit	RW		10	Int16
+16	CriticallyLowWarningLimit	RW		10	Int16
+17	LowShutdownLimit	RW		10	Int16
+18	HighWarningLimit	RW		10	Int16
+19	CriticallyHighWarningLimit	RW		10	Int16
+20	HighShutdownLimit	RW		10	Int16
+21	Deadband	RW		10	Int16
17022	AnalogInput[16][16] Additional analog inputs use the next registers in sequence, with the structure shown above.				

Figure 5-5 Inputs and Outputs

Input/Output Events

Event ID	Level	FMI	Parameter	Prog Input	Prog Output
ParameterValueAbnormal	Shutdown	Low	EngineSpeed		D
ParameterValueAbnormal	Shutdown	High	EngineSpeed		D
ParameterValueAbnormal	Warning	Low	EngineOilPressure		D
ParameterValueAbnormal	Shutdown	Low	EngineOilPressure		D
ParameterValueAbnormal	Shutdown	NoSignal	EngineOilPressure		D
ParameterValueAbnormal	Warning	Low	EngineCoolantTemperature		D
ParameterValueAbnormal	Warning	High	EngineCoolantTemperature		D
ParameterValueAbnormal	Shutdown	High	EngineCoolantTemperature		D
ParameterValueAbnormal	Shutdown	NoSignal	EngineCoolantTemperature		D
ParameterValueAbnormal	Shutdown	Low	EngineCoolantLevel		D
ParameterValueAbnormal	Warning	Low	EngineCoolantLevel		D
ParameterValueAbnormal	Warning	Low	EngineFuelLevel	AD	D
ParameterValueAbnormal	Shutdown	Low	EngineFuelLevel	D	D
ParameterValueAbnormal	Warning	High	EngineFuelLevel	D	D
ParameterValueAbnormal	Warning	CriticallyHigh	EngineFuelLevel	D	D
ParameterValueAbnormal	Warning	Low	FuelPressure	AD	D
ParameterValueAbnormal	Warning	Low	BatteryVoltage		D
ParameterValueAbnormal	Warning	High	BatteryVoltage		D
LowCrankingVoltage	Warning	Low	BatteryVoltage		D
ParameterValueAbnormal	Warning	Low	BatteryCurrent		D
ParameterValueAbnormal	Warning	High	BatteryCurrent		D
ParameterValueAbnormal	Warning	Low	EngineOilLevel	AD	D
ParameterValueAbnormal	Shutdown	Low	EngineOilLevel	D	D
ParameterValueAbnormal	Shutdown	Low	GeneratorVoltageAB		D
ParameterValueAbnormal	Shutdown	High	GeneratorVoltageAB		D
ParameterValueAbnormal	Shutdown	Low	GeneratorVoltageBC		D
ParameterValueAbnormal	Shutdown	High	GeneratorVoltageBC		D
ParameterValueAbnormal	Shutdown	Low	GeneratorVoltageCA		D
ParameterValueAbnormal	Shutdown	High	GeneratorVoltageCA		D
ParameterValueAbnormal	Shutdown	Low	GeneratorFrequency		D
ParameterValueAbnormal	Shutdown	High	GeneratorFrequency		D
ParameterValueAbnormal	Shutdown	High	GeneratorTrueTotalPower		D
ParameterValueAbnormal	Shutdown	Low	MaximumAlternatorCurrent		D
ACSensingLost	Warning				D
ACSensingLost	Shutdown				D
AirDamper	Shutdown				D
AlternatorProtection	Shutdown				D
AuxiliaryInput	Warning			AD	D
AuxiliaryInput	Shutdown			D	D
BatteryChargerFault	Warning			AD	D
BatteryFault	Warning				D
CommonFault	Notice				D
CommonWarning	Notice				D
EcmCommunicationLoss	Shutdown				D
EmergencyStop	Shutdown				D
FuelTankLeak	Warning			AD	D
FuelTankLeak	Shutdown			D	D
GeneratorCommunicationLoss	Warning				D

Event ID	Level	FMI	Parameter	Prog Input	Prog Output
GroundFaultInput	Warning			AD	D
LockedRotor	Shutdown				D
Nfpa110AlarmActive	Notice				D
NoACPower	Warning				D
OverCrank	Shutdown				D
PublicCanCommunicationLoss	Shutdown				D
RemoteReset	Status			D	
SpeedSensorFault	Warning				D
Annunciator1CommunicationLoss	Warning				D
Annunciator2CommunicationLoss	Warning				D
Annunciator3CommunicationLoss	Warning				D
Annunciator4CommunicationLoss	Warning				D
Annunciator5CommunicationLoss	Warning				D
AtsCommunicationError	Warning				D
AtsCommunicationError	Shutdown				D
BlockHeaterControl	Notice				D
ChicagoCodeActive	Notice			AD	D
EngineCoolDownActive	Notice				D
EngineStartAidActive	Notice				D
EngineStartDelayActive	Notice				D
EpsSupplyingLoad	Notice				D
GeneratorRunning	Notice				D
NotInAuto	Warning				D
SystemReady	Notice				D
LowFuel	Notice				D
FuelSpill	Notice				D
MinorFault	Notice				D

Figure 5-6 Input and Output Events

5.6 Event Codes

DeviceEvent structure

The DeviceEvent structure is a 2-register structure, packed with unsigned integer fields as follows:

Bit offset	Value	Description
0 – 7	DeviceEventId	Identifies the type of event.
8 – 10	Level	Indicates the general degree to which the event affects product operation. The type is DeviceEventLevel in <i>PDI</i> .
11 – 15	Fmi	Indicates how the parameter associated with this event is out of range; or NotApplicable.
16 – 31	ParameterId	Parameter related to the event, or None.

Figure 5-7 Device Event Structure

ModbusEvent structure

Register offset	Value	Type	Description
0 – 1	DeviceEvent	DeviceEvent	Identifies the nature of the event.
2 – 5	DateTime	DateTime	When the event occurred in UTC, or 0 if unknown.
6 – 7	ControllerOnTime	UInt32	Duration that the controller has been powered since manufacture, or <i>Unknown</i> . Value is 10 x hours.
8 – 9	EngineRuntime	UInt32	Engine runtime since manufacture, or <i>Unknown</i> . Value is 10 x hours.
10 – 11	Value0	Int32	Value of a parameter related to the event, or <i>Unknown</i> . If DeviceEventId is ParameterChanged, this is the old parameter value.
12 – 13	Value1	Int32	If DeviceEventId is ParameterChanged, the new parameter value; otherwise, <i>Unknown</i> .

Figure 5-8 Modbus Event Structure

Decision-Maker® 3000 Controller		
EventID	Fault Condition	Text to display
1	Parameter Value Abnormal	See Figure 5-10
2	BlockHeaterControl	Non Critical Event
3	NotInAuto	Master Not in Auto
4	OverCrank	Overcrank
5	BatteryChargerFault	Battery Charger Fault
6	LowCrankingVoltage	Low Battery Voltage
7	AirDamper	Air Damper Control
8	EpsSupplyingLoad	EPS Supplying Load
9	GeneratorRunning	Generator Running
10	Nfpa110AlarmActive	NFPA 110 Fault
12	EngineCoolDownActive	Engine Cooldown Delay
13	EngineStartDelayActive	Engine Start Delay
14	EngineStartAidActive	Starting Aid
15	SystemReady	System Ready
16	RemoteStart	Remote Start
17	PublicCanStart	Remote Start
18	ModbusStart	Remote Start
19	EmergencyStop	Emergency Stop
20	AlternatorProtection	Alternator Protect Shutdown
21	GroundFaultInput	Ground Fault
22	ChicagoCodeActive	Chicago Code Active

Decision-Maker® 3000 Controller		
EventID	Fault Condition	Text to display
23	AuxiliaryInput	Aux Delay
24	CommonWarning	Common Warning
25	CommonFault	Common Fault
26	RunRelayCoilOverload	Internal Fault
27	StarterRelayCoilOverload	Internal Fault
28	LockedRotor	Locked Rotor
29	SpeedSensorFault	Speed Sensor Fault
30	ACSensingLost	AC Sensing Loss
32	EngineDerateActive	Engine Derate Active
33	InjectorWiringFault	ECM Fault
34	WaterInFuel	ECM Fault
35	FuelTankLeak	Fuel Leak
36	LossOfFuel	Low Fuel
37	ElectricalMeteringCommunicationLoss	Internal Fault
38	VoltageRegulatorCommunicationLoss	Internal Fault
39	Tps1HigherThanTps2	ECM Fault
40	Tps1LowerThanTps2	ECM Fault
41	Tps1HighVoltage	ECM Fault
42	Tps1LowVoltage	ECM Fault
43	CannotReachHiLoTps	ECM Fault
44	Tps1Tps2SimulVoltageOutOfRange	ECM Fault
45	OilPressureHigh	ECM Fault
46	OilPressureLow	ECM Fault
47	OpsVoltageHigh	ECM Fault
48	OpsVoltageLow	ECM Fault
49	TipActive	ECM Fault
50	TipHighVoltage	ECM Fault
51	TipLowVoltage	ECM Fault
52	IatHigherThanExpected2	ECM Fault
53	IatHighVoltage	ECM Fault
54	IatLowVoltage	ECM Fault
55	IatHigherThanExpected1	ECM Fault
56	MapLowVoltage	ECM Fault
57	MapHighPressure	ECM Fault
58	BpHighPressure	ECM Fault
59	BpLowPressure	ECM Fault
60	EctHigherThanExpected2	ECM Fault
61	EctChtHighVoltage	ECM Fault
62	EctChtLowVoltage	ECM Fault
63	EctHigherThanExpected1	ECM Fault
64	ECMBatteryVoltageHigh	ECM Fault
65	ECMBatteryVoltageLow	ECM Fault
66	SparkRevLimitExceeded	ECM Fault
67	MaxGovernSpeedOverride	ECM Fault
68	FuelRevLimitExceeded	ECM Fault
69	FlashCsumInvalid	ECM Fault
70	InternalEcuFailure	ECM Fault
71	RamFailure	ECM Fault
72	CrankSyncNoise	ECM Fault

Decision-Maker® 3000 Controller		
EventID	Fault Condition	Text to display
73	CrankSignalLost	ECM Fault
74	NoCrankSyncAtStart	ECM Fault
75	ECMCommunicationLoss	ECM Fault
76	ECMAddressConflict	ECM Fault
77	CamSyncNoise	ECM Fault
78	CamSignalLost	ECM Fault
79	Knock1ExcessiveSignal	ECM Fault
80	Knock1SensorOpen	ECM Fault
81	External5V1High	ECM Fault
82	External5V1Low	ECM Fault
83	External5V2High	ECM Fault
84	External5V2Low	ECM Fault
85	MilRelayCoilShortToPower	ECM Fault
86	MilRelayGroundShort	ECM Fault
87	MilRelayCoilOpen	ECM Fault
88	FuelRunOutLongerThanExpected	ECM Fault
89	PrimaryLoopOpen	ECM Fault
90	PrimaryLoopShorted	ECM Fault
91	StartRelayCoilShortToPower	ECM Fault
92	StartRelayGroundShort	ECM Fault
93	PowerRelayCoilShortToPower	ECM Fault
94	PowerRelayGroundShort	ECM Fault
95	PowerRelayCoilOpen	ECM Fault
96	Ego1Open	ECM Fault
97	Tps2HighVoltage	ECM Fault
98	Tps2LowVoltage	ECM Fault
99	ClosedLoopHighNg	ECM Fault
100	ClosedLoopLowNg	ECM Fault
101	AdaptiveLearnHighLpgNG	ECM Fault
102	AdaptiveLearnLowLpgNG	ECM Fault
103	ClosedLoopHighLpg	ECM Fault
104	ClosedLoopLowLpg	ECM Fault
105	Ego2Open	ECM Fault
106	Knock2ExcessiveSignal	ECM Fault
107	Knock2SensorOpen	ECM Fault
108	MjDeliveryPressureHigh	ECM Fault
109	MjDeliveryPressureLow	ECM Fault
110	MjVoltageSupplyHigh	ECM Fault
111	MjVoltageSupplyLow	ECM Fault
112	MjInternalFault	ECM Fault
113	MjCommLost	ECM Fault
125	EngineStarted	Engine Started
126	EngineStopped	Engine Stopped
127	FuelPrimingStarted	Fuel Priming Started
128	FuelPrimingStopped	Fuel Priming Stopped
129	USBDeviceConnected	USB Device Connected
130	USBDeviceDisconnected	USB Device Disconnected
133	DefaultParametersLoaded	Controller Initialized
135	MaintenanceRequired	Maintenance Required

Decision-Maker® 3000 Controller		
EventID	Fault Condition	Text to display
139	FirmwareUpgradeFault	Internal Fault
140	FirmwareUpgradeIntegrityTestFailed	Internal Fault
141	FirmwareStartupIntegrityTestFailed	Internal Fault
142	SystemTimerFailed	Internal Fault
143	WatchdogTimerExpired	Internal Fault
144	InternalFailure	Internal Fault
145	FileSystemError	Internal Fault
146	USBError	Internal Fault
147	PublicCanCommunicationLoss	Loss of ECM Comm
148	GeneratorCommunicationLoss	Loss of ECM Comm
156	OptionBoard1CommunicationLoss	Option Board1 Communication Loss
157	OptionBoard2CommunicationLoss	Option Board2 Communication Loss
158	OptionBoard3CommunicationLoss	Option Board3 Communication Loss
159	OptionBoard4CommunicationLoss	Option Board4 Communication Loss
163	TestEvent	Test Event
176	ECMModelMismatch	ECM Model Mismatch
177	BackupParametersLoaded	Backup Parameters Loaded
178	AutoRecovery	Auto Recovery
179	RemoteReset	Remote Reset
181	ECMUnknownFault	ECM Unknown Fault
222	LowFuel	Low Fuel
223	FuelSpill	Fuel Spill
224	MinorFault	Minor Fault
225	J1939CANSShutdown	J1939 CANSShutdown

Figure 5-9 Event Codes, Decision-Maker® 3000 Controller

Decision-Maker® 3000 Controller				
EventID	Level	FMI	ParamID	Text to display
1	4	16	1100	Overspeed
1	4	18	1100	Underspeed
1	2	18	1102	Low Oil Pressure Warning
1	4	18	1102	Low Oil Pressure Shutdown
1	2	18	1103	Low Coolant Temperature
1	2	16	1103	High Coolant Temp Warning
1	4	16	1103	High Coolant Temp Shutdown
1	4	5	1103	No Coolant Temp Signal
1	4	18	1105	Low Coolant Level Shutdown
1	2	18	1106	Low Fuel Warning
1	4	18	1106	Low Fuel Shutdown
1	2	16	1106	High Fuel Warning
1	2	0	1106	Critically High Fuel Warning
1	2	18	1110	Low Fuel Pressure Warning
1	2	18	1107	Low Battery Voltage
1	2	16	1107	High Battery Voltage
1	2	18	1104	Low Oil Level Warning
1	4	18	1104	Low Oil Level Shutdown
1	4	18	1334	Under Voltage
1	4	16	1334	Over Voltage
1	4	18	1336	Under Voltage
1	4	16	1336	Over Voltage
1	4	18	1338	Under Voltage
1	4	16	1338	Over Voltage
1	4	18	1358	Under Frequency
1	4	16	1358	Over Frequency
1	4	16	1331	Over Power Shutdown
1	4	16	1601	Low Maximum Alternator Current

Figure 5-10 Event ID 1, Parameter Value Abnormal, Decision-Maker® 3000 Controller

Section 6 Decision-Maker 3500 Generator Set Controller

6.1 Specifications

The Decision-Maker® 3500 controller's Modbus® communication capability:

- Supports industry-standard Modbus® RTU protocol.
- Can use Modbus® TCP protocol with the addition of a Modbus/Ethernet converter.
- Uses RS-485 connections to connect to a Modbus® master singly or over an RS-485 network.
- Connects to an Ethernet network using a Modbus/Ethernet converter.
- Uses standard baud rates of 9600, 19200, 38400, or 57600.



Figure 6-1 Decision-Maker® 3500 Controller

6.2 Hardware Connections

⚠ WARNING

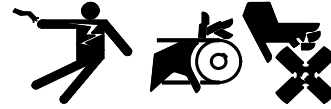

Accidental starting. Can cause severe injury or death.

Disconnect the battery cables before working on the generator set. Remove the negative (-) lead first when disconnecting the battery. Reconnect the negative (-) lead last when reconnecting the battery.

Disabling the generator set. Accidental starting can cause severe injury or death. Before working on the generator set or equipment connected to the set, disable the generator set as follows: (1) Press the generator set off/reset button to shut down the generator set. (2) Disconnect the power to the battery charger, if equipped. (3) Remove the battery cables, negative (-) lead first. Reconnect the negative (-) lead last when reconnecting the battery. Follow these precautions to prevent the starting of the generator set by the remote start/stop switch.

Circuit isolation is recommended for installations that may be exposed to electrical noise. See Appendix B, Noise and Wiring Practices.

Use the following procedure to connect the hardware. Observe the safety precautions. Also see the network connection diagrams in TT-1405.

Ethernet connections require the use of a Modbus/Ethernet converter module. See TT-1405 for Modbus/Ethernet converter connection and setup information.

Decision-Maker 3500 Connection Procedure

1. Press the OFF button on the controller.
2. Disconnect the power to the battery charger, if equipped.
3. Disconnect the generator set engine starting battery(ies), negative (-) lead first.
4. Turn off and disconnect the power to all devices in the system.
5. Connect to communication port on TB12 (located in the junction box) as shown in Figure 6-2.
6. Verify that the controller is OFF.
7. Reconnect the generator set engine starting battery, negative (-) lead last.
8. Reconnect power to the battery charger, if equipped.

6.3 Controller Setup

Use Kohler® SiteTech™ software and a personal computer connected to the controller's USB port to configure the controller's communication parameters shown in Figure 6-3. See TP-6701, SiteTech Software Operation Manual, for instructions.

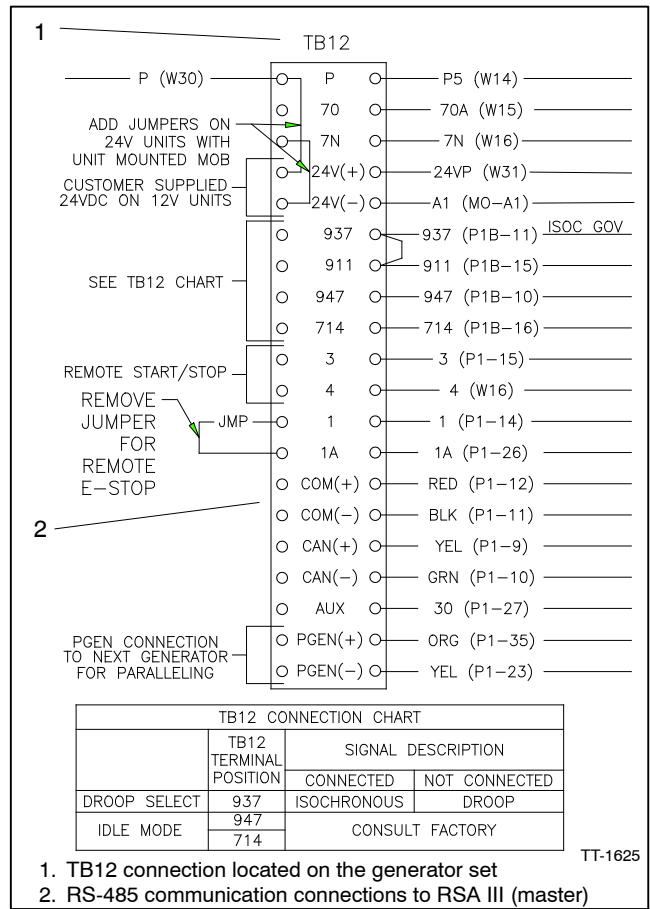

Note: Use Belden #9844 or equivalent

TB12 Connector	Circuit Board Designation	Wire Designation
COM (+)	(+)	White
COM (-)	(-)	Black
Do not connect at TB12 or DEC 3500, tape to insulate unused end.		Shield
Note: When using RS-485 communication cable, connect the "shield" wire at the RSA III P27 connection but not at the DEC 3500 controller/TB12 connection.		

Figure 6-2 Connection Details

SiteTech Group	Parameter	Setting
Modbus	Address	Use a unique network address between 1 and 247 for each unit. Use 1 for a single connection. Do not use 0 (zero).
	Baud rate	9600, 19200, 38400, or 57600. Must match the PC and all devices in the system.

Figure 6-3 Decision-Maker 3500 Communication Parameters

6.4 Modbus Registers

This section contains Modbus® registers for the Decision-Maker® 3500 controller. Refer to Section 1.3 for definitions of terms and symbols used in the register tables.

Time delays, setpoints, inputs and outputs, and other user-defined parameters are entered through the controller keypad or SiteTech™ software. Refer to the operation manuals for the controller or software for instructions. See the List of Related Materials for document part numbers.

Note: FFC0 = Unsupported register.

Register	Parameter	Write Access	Units	Data Type	Type/Notes
400001	RMS Generator Voltage L1-L2	RO	% X 100	UINT	% of Rated VAC
400002	RMS Generator Voltage L2-L3	RO	% X 100	UINT	% of Rated VAC
400003	RMS Generator Voltage L3-L1	RO	% X 100	UINT	% of Rated VAC
400004	RMS Generator Voltage Line to Line Average	RO	% X 100	UINT	% of Rated VAC
400005	RMS Generator Voltage L1-N	RO	% X 100	UINT	% of Rated VAC
400006	RMS Generator Voltage L2-N	RO	% X 100	UINT	% of Rated VAC
400007	RMS Generator Voltage L3-N	RO	% X 100	UINT	% of Rated VAC
400008	RMS Generator Voltage Line to Neutral Average	RO	% X 100	UINT	% of Rated VAC
400009	RMS Generator Current L1	RO	% X 100	UINT	% of Rated Current (RMS)
400010	RMS Generator Current L2	RO	% X 100	UINT	% of Rated Current (RMS)
400011	RMS Generator Current L3	RO	% X 100	UINT	% of Rated Current (RMS)
400012	RMS Generator Current Average	RO	% X 100	UINT	% of Rated Current (RMS)
400013	Generator Frequency	RO	X 100	UINT	Hz
400014	Generator Real Power L1	RO	% X 100	INT	% of Rated kW (Full Real Load = 33.3%)
400015	Generator Real Power L2	RO	% X 100	INT	% of Rated kW (Full Real Load = 33.3%)
400016	Generator Real Power L3	RO	% X 100	INT	% of Rated kW (Full Real Load = 33.3%)
400017	Generator Total Real Power	RO	% X 100	INT	% of Rated kW
400018	Generator Reactive Power L1	RO	% X 100	INT	% of Rated kW (Full Reactive Load = 25%)
400019	Generator Reactive Power L2	RO	% X 100	INT	% of Rated kW (Full Reactive Load = 25%)
400020	Generator Reactive Power L3	RO	% X 100	INT	% of Rated kW (Full Reactive Load = 25%)
400021	Generator Reactive Power	RO	% X 100	INT	% of Rated kW (Full Reactive Load = 75%)
400022	Generator Apparent Power L1	RO	% X 100	UINT	% of Rated kW (Full Alternator Load = 41.7%)
400023	Generator Apparent Power L2	RO	% X 100	UINT	% of Rated kW (Full Alternator Load = 41.7%)
400024	Generator Apparent Power L3	RO	% X 100	UINT	% of Rated kW (Full Alternator Load = 41.7%)
400025	Generator Apparent Power	RO	% X 100	UINT	% of Rated kW (Full Alternator Load = 125%)
400026	Generator Power Factor L1	RO	pF X 100	INT	Generator Output Power Factor (- = reverse Power)

Register	Parameter	Write Access	Units	Data Type	Type/Notes
400027	Generator Power Factor L2	RO	pF X 100	INT	Generator Output Power Factor (- = reverse Power)
400028	Generator Power Factor L3	RO	pF X 100	INT	Generator Output Power Factor (- = reverse Power)
400029	Generator Power Factor	RO	pF X 100	INT	Generator Output Power Factor (- = reverse Power)
400030	Generator Phase Angle Voltage L1-Voltage L2	RO	° X 10	INT	Phase difference in Degrees
400031	Generator Phase Angle Voltage L1-Voltage L3	RO	° X 10	INT	Phase difference in Degrees
400032	Generator Phase Angle Voltage L1-Current L1	RO	° X 10	INT	Phase difference in Degrees
400033	Generator Phase Angle Voltage L2-Current L2	RO	° X 10	INT	Phase difference in Degrees
400034	Generator Phase Angle Voltage L3-Current L3	RO	° X 10	INT	Phase difference in Degrees
400035	Phase Rotation	RO	UNIQUE	PHASE_ROT	0 = Unknown, 1 = ABC, 2 = CBA, 3 = Single-Phase
400036	Generator L1 Current Lead/Lag	RO	UNIQUE	LEAD/LAG	0 = Invalid, 1 = Leading, 2 = Lagging
400037	Generator L2 Current Lead/Lag	RO	UNIQUE	LEAD/LAG	0 = Invalid, 1 = Leading, 2 = Lagging
400038	Generator L3 Current Lead/Lag	RO	UNIQUE	LEAD/LAG	0 = Invalid, 1 = Leading, 2 = Lagging
400039	Generator Average Current Lead/Lag	RO	UNIQUE	LEAD/LAG	0 = Invalid, 1 = Leading, 2 = Lagging
400040 thru 400043	RESERVED for factory use				
400044	RMS Bus Voltage L1-L2	RO	% X 100	UINT	% of Rated VAC
400045	RMS Bus Voltage L2-L3	RO	% X 100	UINT	% of Rated VAC
400046	RMS Bus Voltage L3-L1	RO	% X 100	UINT	% of Rated VAC
400047	RMS Bus Voltage Average Line to Line	RO	% X 100	UINT	% of Rated VAC
400048	Total Bus Real Power	RO	% X 100	INT	% of Rated kW
400049	Total Bus Reactive Power	RO	% X 100	INT	% of Rated kW (Full Reactive Load = 75%)
400050	Bus Frequency	RO	X 100	UINT	Hz
400051	Bus Phase Rotation	RO	UNIQUE	PHASE_ROT	0 = Unknown, 1 = ABC, 2 = CBA, 3 = Single-Phase
400052	Phase Angle Generator Voltage L1-Bus Voltage L1	RO	° X 10	INT	Phase difference in Degrees
400053	Speed Bias	RO	% X 100	INT	Adjustment provided to Speed (100% = 10% change in speed)
400054	Voltage Bias	RO	% X 100	INT	Adjustment provided to Voltage (100% = 10% change in voltage)
400055 thru 400058	RESERVED for factory use				

Register	Parameter	Write Access	Units	Data Type	Type/Notes
400059	Engine Oil Pressure	RO	kPA X 10	UINT	kPA
400060	Engine Coolant Temperature	RO	°C X 10	INT	°C
400061	Engine Speed	RO	RPM	UINT	RPM
400062	Battery Voltage	RO	V X 10	UINT	V
400063	Controller Temperature	RO	°C X 10	INT	°C
400064	Engine Fuel Pressure	RO	kPA / 100	UINT	kPA
400065	Engine Fuel Temperature	RO	°C X 10	INT	°C
400066	Engine Fuel Rate	RO	liters / hour	UINT	l/hr
400067	Fuel Used During Last Run	RO	liters	UINT	l
400068	Engine Coolant Pressure	RO	kPA X 10	UINT	kPA
400069	Engine Coolant Level	RO	% X 100	UINT	%
400070	Engine Oil Temperature	RO	°C X 10	INT	°C
400071	Engine Oil Level	RO	% X 100	UINT	%
400072	Engine Crankcase Pressure	RO	kPA X 10	UINT	kPA
400073	Intake Air Temperature	RO	°C X 10	INT	°C
400074	Intake Air Pressure	RO	kPA	UINT	kPA
400075	ECM Ambient Temperature	RO	°C X 10	INT	°C
400076	ECM Battery Voltage	RO	V X 10	UINT	V
400077	ECM Model	RO	UNIQUE	UINT	
400078	ECM Fault Codes	RO	UNIQUE	UINT	
400079 thru 400082	RESERVED for factory use				
400083	Total Runtime Hours LW	RO	h X 10	UDINT	h
400084	Total Runtime Hours HW	RO			
400085	Total Runtime Loaded Hours LW	RO	h X 10	UDINT	h
400086	Total Runtime Loaded Hours HW	RO			
400087	Total Runtime Unloaded Hours LW	RO	h X 10	UDINT	h
400088	Total Runtime Unloaded Hours HW	RO			
400089	Total Runtime kW Hours LW	RO	kWh	UDINT	kWh
400090	Total Runtime kW Hours HW	RO			
400091	Code Version MSB = Minor, LSB = Major	RO	UNIQUE		
400092	Code Version Build Number	RO	UNIQUE		
400093 thru 400096	RESERVED for factory use				
400097	LSB = Day, MSB = Month	RW	Day of Month, Month of Year	UINT	
400098	Year	RW	16 bit year (A.D.)	UINT	
400099	mSecond	RW	seconds X 1000	UINT	
400100	LSB = Minute, MSB = Hour	RW	Minutes past Hour, Hours past Midnight	UINT	
400101 thru 400104	RESERVED for factory use				
400105	System Voltage	RW	V	UINT	V
400106	System Frequency	RW	Hz	UINT	Hz
400107	System Phase Connection	RW	UNIQUE	Voltage Phase Connection	0 = Single-Phase, 1 = DogLeg, 2 = Wye, 3 = Delta
400108	Rated Current	RO	A	UINT	A
400109	Genset kW Rating	RO	kW X 10	UINT	kW
400110	System Battery Voltage	RW	V	UINT	V

Register	Parameter	Write Access	Units	Data Type	Type/Notes
400111	Engine Run Speed	RO	RPM X 1	UINT	RPM
400112 thru 400512	RESERVED for factory use, not readable				
400513	Total Number of Starts	RO		UINT	
400514	Total Runtime Hours Since Maintenance LW	RO	hr X 10	UDINT	hr
400515	Total Runtime Hours Since Maintenance HW	RO			
400516	Total Loaded Hours Since Maintenance LW	RO	hr X 10	UDINT	hr
400517	Total Loaded Hours Since Maintenance HW	RO			
400518	Total kW Hours Since Maintenance LW	RO	kWh	UDINT	kWh
400519	Total kW Hours Since Maintenance HW	RO			
400520	Last Maintenance Day, Month	RO	Day of Month, Month of Year	UINT	
400521	Last Maintenance Year	RO	16 bit year (A.D.)	UINT	
400522	Last Maintenance mSecond	RO	seconds X 1000	UINT	
400523	Last Maintenance Minute, Hour	RO	Minutes past Hour, Hours past Midnight	UINT	
400524	Operating Days Since Last Maintenance	RO	days	UINT	days
400525	Number of Starts Since Last Maintenance	RO		UINT	
400526	Last Start Day, Month	RO	Day of Month, Month of Year	UINT	
400527	Last Start Year	RO	16 bit year (A.D.)	UINT	
400528	Last Start mSecond	RO	seconds X 1000	UINT	
400529	Last Start Minute, Hour	RO	Minutes past Hour, Hours past Midnight	UINT	
400530 thru 400604	RESERVED for factory use, not readable				
400605	Ecm Start Delay	RW	sec	UINT	
400606	Engine Start Delay	RW	sec	UINT	
400607	Starting Aid Delay	RW	sec	UINT	
400608	Crank On Time Delay	RW	sec	UINT	
400609	Crank Pause Time Delay	RW	sec	UINT	
400610	Engine Cooldown Time Delay	RW	sec	UINT	
400611	OverVoltage Time Delay	RW	sec	UINT	
400612	UnderVoltage Time Delay	RW	sec	UINT	
400613	RESERVED for factory use	RO	sec	UINT	
400614	Low Battery Voltage Delay	RW	sec	UINT	
400615	High Battery Voltage Delay	RW	sec	UINT	
400616	Speed Adjust	RW		UINT	
400617	Voltage Adjust	RW	% X 100	UINT	% of Rated VAC
400618	Warmed Up Temperature	RO	°C	INT	°C
400619	Cooled Down Temperature	RO	°C	INT	°C
400620	Engine Low Coolant Temperature Warning Limit	RO	°C X 10	INT	°C
400621	Engine High Coolant Temperature Warning Limit	RO	°C X 10	INT	°C
400622	RESERVED for factory use	RO	°C X 10	INT	°C
400623	Engine High Coolant Temperature Shutdown Limit	RO	°C X 10	INT	°C
400624	Engine Low Oil Pressure Warning Limit	RO	kPA X 10	UINT	kPA

Register	Parameter	Write Access	Units	Data Type	Type/Notes
400625	Engine Low Oil Pressure Shutdown Limit	RO	kPA X 10	UINT	kPA
400626	RESERVED for factory use	RO	%	UINT	% of Rated kW
400627	OverVoltage Level	RW	%	UINT	% of Rated VAC
400628	UnderVoltage Level	RW	%	UINT	% of Rated VAC
400629	OverFrequency Level	RW	%	UINT	% of Rated Hz
400630	UnderFrequency Level	RW	%	UINT	% of Rated Hz
400631	UnderSpeed Level	RW	%	UINT	% of Engine Run Speed
400632	OverSpeed Level	RW	%	UINT	% of Engine Run Speed
400633	Low Battery Voltage Warning Level	RW	%	UINT	% of System Battery Voltage
400634	High Battery Voltage Warning Level	RW	%	UINT	% of System Battery Voltage
400635	Number of Crank Cycles	RW		UINT	
400636 thru 400638	RESERVED for factory use *				
400639	Volts/Hz Cut In Frequency	RW	Hz X 10	UINT	Hz
400640	Volts/Hz Slope	RW	%	UINT	Volts/Hz
400641	Voltage Regulator Gain	RW		UINT	
400642	Voltage Normal Ramp Rate †	RW		UINT	
400643	RESERVED for factory use	RW		UINT	
400644	Cooldown Temperature Override	RW		UINT	
400645	Genset Controller Date Format	RW		UNIQUE	DateFormat 0 = MM-DD-YY, 1 = DD-MM-YY
400646	Genset Controller Time Format †	RW		UNIQUE	TimeFormat 0 = 12 Hr, 1 = 24 Hr
400647	Post Heat Delay Seconds †	RW	Sec	UINT	Post Heat Time Delay
400648	Starting Aid Temp Limit †	RW	°C	INT	Coolant temp threshold
400649	Engine Idle Duration †	RW	Sec	UINT	Coolant temp threshold
400650 thru 400659	RESERVED for factory use *				
400660	Overpower Protective Relay Level	RW		UINT	% of Rated Power
400661	Overpower Protective Relay Time Delay	RW		UINT	sec X 10
400662	Reverse Power Protective Relay Level	RW		UINT	% of Rated Power
400663	Reverse Power Protective Relay Time Delay	RW		UINT	sec X 10
400664	OverVoltage Protective Relay Level	RW		UINT	% of Rated Voltage
400665	OverVoltage Protective Relay Time Delay	RW		UINT	sec X 10
400666	UnderVoltage Protective Relay Level	RW		UINT	% of Rated Voltage
400667	UnderVoltage Protective Relay Time Delay	RW		UINT	sec X 10
400668	OverFrequency Protective Relay Level	RW		UINT	% of Rated Frequency
400669	OverFrequency Protective Relay Time Delay	RW		UINT	sec X 10
400670	UnderFrequency Protective Relay Level	RW		UINT	% of Rated Frequency
400671	UnderFrequency Protective Relay Time Delay	RW		UINT	sec X 10
400672	Loss of Field Protective Relay Level	RW		UINT	% of Rated kVAR (Typically 75% of Rated kW)
400673	Loss of Field Protective Relay Time Delay	RW		UINT	sec X 10
400674	OverCurrent Protective Relay Level	RW		UINT	% of Rated Current
400675	OverCurrent Protective Relay Time Delay	RW		UINT	sec X 10
400676	OverPower Shutdown Level	RO		UINT	% of Rated Power (102/112% kW Overload)
400677	OverPower Shutdown Time Delay	RO		UINT	sec X 1 (102/112% kW Overload)
400678	Synch Check Voltage Window †	RW		UINT	% X 100
400679	Synch Check Frequency Window †	RW		UINT	Hz X 100
400680	Synch Check Phase Window †	RW		UINT	° X 100

Register	Parameter	Write Access	Units	Data Type	Type/Notes
400681	Synch Check Dwell Time †	RW		UINT	sec X 10
400682	BreakerTripToShutdownTime †	RW		UINT	sec X 10
400683 thru 400799	RESERVED for factory use				
400800	Gen Management Control Mode	RW ‡		UNIQUE	1 = Manual, 2 = Runtime, 3 = Fuel Level
400801	Gen Management Enabled	RW ‡		BOOL	
400802	Gen Management Order	RW ‡		UINT	
400803	Gen Management Start Percent	RW ‡	% X 10	UINT	
400804	Gen Management Stop Percent	RW ‡	% X 10	UINT	
400805	Gen Management Start Delay	RW ‡	s	UINT	
400806	Gen Management Stop Delay	RW ‡	s	UINT	
400807	Gen Management Start Accumulator LW	RO			
400808	Gen Management Start Accumulator HW	RO	% X 10000	UDINT	
400809	Gen Management Stop Accumulator LW	RO			
400810	Gen Management Stop Accumulator HW	RO	% X 10000	UDINT	
400811	Gen Management Start KW	RO	kW	UINT	
400812	Gen Management Stop KW	RO	kW	UINT	
400813	Gen Management Stable Delay	RW ‡	s	UINT	
400814	Gen Management Run Time Threshold	RW ‡	h X 10	UINT	
400815	Gen Management Fuel Difference Threshold	RW ‡	%	UINT	
400816	Gen Management Min Gens Online	RW ‡		UINT	
400817	Gen Management Min Load Shed Priority	RW ‡		UINT	
400818	Gen Management Stopped By Gen Mgmt	RO		BOOL	
400819	Gen Management Total Bus Capacity	RO	kW	UINT	
400820 thru 400894	RESERVED for factory use				
400895	Number of Active Events	RO		UINT	
400896	Active Event1 Level and FMI	RO		UINT	
400897	Active Event1 Object ID	RO		UINT	
400898	Active Event1 Event Id	RO		UINT	
400899	Active Event1 ParameterId	RO		UINT	
400900	Active Event2 Level and FMI	RO		UINT	
400901	Active Event2 Object ID	RO		UINT	
400902	Active Event2 Event Id	RO		UINT	
400903	Active Event2 ParameterId	RO		UINT	
400904	Active Event3 Level and FMI	RO		UINT	
400905	Active Event3 Object ID	RO		UINT	
400906	Active Event3 Event Id	RO		UINT	
400907	Active Event3 ParameterId	RO		UINT	
400908	Active Event4 Level and FMI	RO		UINT	
400909	Active Event4 Object ID	RO		UINT	
400910	Active Event4 Event Id	RO		UINT	
400911	Active Event4 ParameterId	RO		UINT	
400912	Active Event5 Level and FMI	RO		UINT	
400913	Active Event5 Object ID	RO		UINT	
400914	Active Event5 Event Id	RO		UINT	
400915	Active Event5 ParameterId	RO		UINT	
400916	Active Event6 Level and FMI	RO		UINT	
400917	Active Event6 Object ID	RO		UINT	
400918	Active Event6 Event Id	RO		UINT	
400919	Active Event6 ParameterId	RO		UINT	
400920	Active Event7 Level and FMI	RO		UINT	
400921	Active Event7 Object ID	RO		UINT	
400922	Active Event7 Event Id	RO		UINT	
400923	Active Event7 ParameterId	RO		UINT	

Register	Parameter	Write Access	Units	Data Type	Type/Notes
400924	Active Event8 Level and FMI	RO		UINT	
400925	Active Event8 Object ID	RO		UINT	
400926	Active Event8 Event Id	RO		UINT	
400927	Active Event8 ParameterId	RO		UINT	
400928	Active Event9 Level and FMI	RO		UINT	
400929	Active Event9 Object ID	RO		UINT	
400930	Active Event9 Event Id	RO		UINT	
400931	Active Event9 ParameterId	RO		UINT	
400932	Active Event10 Level and FMI	RO		UINT	
400933	Active Event10 Object ID	RO		UINT	
400934	Active Event10 Event Id	RO		UINT	
400935	Active Event10 ParameterId	RO		UINT	
400936	Active Event11 Level and FMI	RO		UINT	
400937	Active Event11 Object ID	RO		UINT	
400938	Active Event11 Event Id	RO		UINT	
400939	Active Event11 ParameterId	RO		UINT	
400940	Active Event12 Level and FMI	RO		UINT	
400941	Active Event12 Object ID	RO		UINT	
400942	Active Event12 Event Id	RO		UINT	
400943	Active Event12 ParameterId	RO		UINT	
400944	Active Event13 Level and FMI	RO		UINT	
400945	Active Event13 Object ID	RO		UINT	
400946	Active Event13 Event Id	RO		UINT	
400947	Active Event13 ParameterId	RO		UINT	
400948	Active Event14 Level and FMI	RO		UINT	
400949	Active Event14 Object ID	RO		UINT	
400950	Active Event14 Event Id	RO		UINT	
400951	Active Event14 ParameterId	RO		UINT	
400952	Active Event15 Level and FMI	RO		UINT	
400953	Active Event15 Object ID	RO		UINT	
400954	Active Event15 Event Id	RO		UINT	
400955	Active Event15 ParameterId	RO		UINT	
400956	Active Event16 Level and FMI	RO		UINT	
400957	Active Event16 Object ID	RO		UINT	
400958	Active Event16 Event Id	RO		UINT	
400959	Active Event16 ParameterId	RO		UINT	
400960	Active Event17 Level and FMI	RO		UINT	
400961	Active Event17 Object ID	RO		UINT	
400962	Active Event17 Event Id	RO		UINT	
400963	Active Event17 ParameterId	RO		UINT	
400964	Active Event18 Level and FMI	RO		UINT	
400965	Active Event18 Object ID	RO		UINT	
400966	Active Event18 Event Id	RO		UINT	
400967	Active Event18 ParameterId	RO		UINT	
400968	Active Event19 Level and FMI	RO		UINT	
400969	Active Event19 Object ID	RO		UINT	
400970	Active Event19 Event Id	RO		UINT	
400971	Active Event19 ParameterId	RO		UINT	
400972	Active Event20 Level and FMI	RO		UINT	
400973	Active Event20 Object ID	RO		UINT	
400974	Active Event20 Event Id	RO		UINT	
400975	Active Event20 ParameterId	RO		UINT	
400976	Active Event21 Level and FMI	RO		UINT	
400977	Active Event21 Object ID	RO		UINT	
400978	Active Event21 Event Id	RO		UINT	
400979	Active Event21 ParameterId	RO		UINT	
400980	Active Event22 Level and FMI	RO		UINT	
400981	Active Event22 Object ID	RO		UINT	

Register	Parameter	Write Access	Units	Data Type	Type/Notes
400982	Active Event22 Event Id	RO		UINT	
400983	Active Event22 ParameterId	RO		UINT	
400984	Active Event23 Level and FMI	RO		UINT	
400985	Active Event23 Object ID	RO		UINT	
400986	Active Event23 Event Id	RO		UINT	
400987	Active Event23 ParameterId	RO		UINT	
400988	Active Event24 Level and FMI	RO		UINT	
400989	Active Event24 Object ID	RO		UINT	
400990	Active Event24 Event Id	RO		UINT	
400991	Active Event24 ParameterId	RO		UINT	
400992	Active Event25 Level and FMI	RO		UINT	
400993	Active Event25 Object ID	RO		UINT	
400994	Active Event25 Event Id	RO		UINT	
400995	Active Event25 ParameterId	RO		UINT	
400996	Active Event26 Level and FMI	RO		UINT	
400997	Active Event26 Object ID	RO		UINT	
400998	Active Event26 Event Id	RO		UINT	
400999	Active Event26 ParameterId	RO		UINT	
401000	Active Event27 Level and FMI	RO		UINT	
401001	Active Event27 Object ID	RO		UINT	
401002	Active Event27 Event Id	RO		UINT	
401003	Active Event27 ParameterId	RO		UINT	
401004	Active Event28 Level and FMI	RO		UINT	
401005	Active Event28 Object ID	RO		UINT	
401006	Active Event28 Event Id	RO		UINT	
401007	Active Event28 ParameterId	RO		UINT	
401008	Active Event29 Level and FMI	RO		UINT	
401009	Active Event29 Object ID	RO		UINT	
401010	Active Event29 Event Id	RO		UINT	
401011	Active Event29 ParameterId	RO		UINT	
401012	Active Event30 Level and FMI	RO		UINT	
401013	Active Event30 Object ID	RO		UINT	
401014	Active Event30 Event Id	RO		UINT	
401015	Active Event30 ParameterId	RO		UINT	
401016	Active Event Select	RW		UINT	
401017	Selected Active Event Level and FMI	RO		UINT	
401018	Selected Active Event Object ID	RO		UINT	
401019	Selected Active Event Event Id	RO		UINT	
401020	Selected Active Event ParameterId	RO		UINT	
401021 thru 401034	RESERVED for factory use				
401035	Characters 1 and 2 of String for Genset Model Number	RO		STRING	
401036	Characters 3 and 4 of String for Genset Model Number				
401037	Characters 5 and 6 of String for Genset Model Number				
401038	Characters 7 and 8 of String for Genset Model Number				
401039	Characters 9 and 10 of String for Genset Model Number				
401040	Characters 11 and 12 of String for Genset Model Number				
401041	Characters 13 and 14 of String for Genset Model Number				
401042	Characters 15 and 16 of String for Genset Model Number				

Register	Parameter	Write Access	Units	Data Type	Type/Notes
401043	Characters 17 and 18 of String for Genset Model Number	RO		STRING	
401044	Characters 19 and 20 of String for Genset Model Number				
401045	Characters 21 and 22 of String for Genset Model Number				
401046	Characters 23 and 24 of String for Genset Model Number				
401047	Characters 25 and 26 of String for Genset Model Number				
401048	Characters 1 and 2 of String for Controller Serial Number	RO		STRING	
401049	Characters 3 and 4 of String for Controller Serial Number				
401050	Characters 5 and 6 of String for Controller Serial Number				
401051	Characters 7 and 8 of String for Controller Serial Number				
401052	Characters 9 and 10 of String for Controller Serial Number				
401053	Characters 11 and 12 of String for Controller Serial Number				
401054	Characters 13 and 14 of String for Controller Serial Number				
401055	Characters 15 and 16 of String for Controller Serial Number				
401056	Characters 17 and 18 of String for Controller Serial Number				
401057	Characters 19 and 20 of String for Controller Serial Number				
401058	Characters 1 and 2 of String for Genset Spec Number				
401059	Characters 3 and 4 of String for Genset Spec Number				
401060	Characters 5 and 6 of String for Genset Spec Number				
401061	Characters 7 and 8 of String for Genset Spec Number				
401062	Characters 9 and 10 of String for Genset Spec Number				
401063	Characters 11 and 12 of String for Genset Spec Number				
401064	Characters 13 and 14 of String for Genset Spec Number				
401065	Characters 15 and 16 of String for Genset Spec Number				
401066	Characters 17 and 18 of String for Genset Spec Number				
401067	Characters 19 and 20 of String for Genset Spec Number				
401068	Characters 1 and 2 of String for Genset Serial Number	RO		STRING	
401069	Characters 3 and 4 of String for Genset Serial Number				
401070	Characters 5 and 6 of String for Genset Serial Number				
401071	Characters 7 and 8 of String for Genset Serial Number				
401072	Characters 9 and 10 of String for Genset Serial Number				

Register	Parameter	Write Access	Units	Data Type	Type/Notes
401073	Characters 11 and 12 of String for Genset Serial Number	RO		STRING	
401074	Characters 13 and 14 of String for Genset Serial Number				
401075	Characters 15 and 16 of String for Genset Serial Number				
401076	Characters 17 and 18 of String for Genset Serial Number				
401077	Characters 19 and 20 of String for Genset Serial Number				
401078	Characters 1 and 2 of String for Alternator Part Number	RO		STRING	
401079	Characters 3 and 4 of String for Alternator Part Number				
401080	Characters 5 and 6 of String for Alternator Part Number				
401081	Characters 7 and 8 of String for Alternator Part Number				
401082	Characters 9 and 10 of String for Alternator Part Number				
401083	Characters 11 and 12 of String for Alternator Part Number				
401084	Characters 13 and 14 of String for Alternator Part Number				
401085	Characters 15 and 16 of String for Alternator Part Number				
401086	Characters 17 and 18 of String for Alternator Part Number				
401087	Characters 19 and 20 of String for Alternator Part Number				
401088	Characters 1 and 2 of String for Engine Part Number				
401089	Characters 3 and 4 of String for Engine Part Number				
401090	Characters 5 and 6 of String for Engine Part Number				
401091	Characters 7 and 8 of String for Engine Part Number				
401092	Characters 9 and 10 of String for Engine Part Number				
401093	Characters 11 and 12 of String for Engine Part Number				
401094	Characters 13 and 14 of String for Engine Part Number				
401095	Characters 15 and 16 of String for Engine Part Number				
401096	Characters 17 and 18 of String for Engine Part Number				
401097	Characters 19 and 20 of String for Engine Part Number				
401098	Characters 1 and 2 of String for Engine Model Number	RO		STRING	
401099	Characters 3 and 4 of String for Engine Model Number				
401100	Characters 5 and 6 of String for Engine Model Number				
401101	Characters 7 and 8 of String for Engine Model Number				
401102	Characters 9 and 10 of String for Engine Model Number				

Register	Parameter	Write Access	Units	Data Type	Type/Notes
401103	Characters 11 and 12 of String for Engine Model Number	RO		STRING	
401104	Characters 13 and 14 of String for Engine Model Number				
401105	Characters 15 and 16 of String for Engine Model Number				
401106	Characters 17 and 18 of String for Engine Model Number				
401107	Characters 19 and 20 of String for Engine Model Number				
401108	Characters 1 and 2 of String for Engine Serial Number	RO		STRING	
401109	Characters 3 and 4 of String for Engine Serial Number				
401110	Characters 5 and 6 of String for Engine Serial Number				
401111	Characters 7 and 8 of String for Engine Serial Number				
401112	Characters 9 and 10 of String for Engine Serial Number				
401113	Characters 11 and 12 of String for Engine Serial Number				
401114	Characters 13 and 14 of String for Engine Serial Number				
401115	Characters 15 and 16 of String for Engine Serial Number				
401116	Characters 17 and 18 of String for Engine Serial Number				
401117	Characters 19 and 20 of String for Engine Serial Number				
401118	Characters 1 and 2 of String for ECM Serial Number				
401119	Characters 3 and 4 of String for ECM Serial Number				
401120	Characters 5 and 6 of String for ECM Serial Number				
401121	Characters 7 and 8 of String for ECM Serial Number				
401122	Characters 9 and 10 of String for ECM Serial Number				
401123	Characters 11 and 12 of String for ECM Serial Number				
401124	Characters 13 and 14 of String for ECM Serial Number				
401125	Characters 15 and 16 of String for ECM Serial Number				
401126	Characters 17 and 18 of String for ECM Serial Number				
401127	Characters 19 and 20 of String for ECM Serial Number				
401128 thru 409996	RESERVED for factory use, not readable				
409997	Vendor	RO		UINT	7728 for Kohler Co.
409998	Modbus Map Version	RO		UINT	1 for this map, (initial release)
409999	Controller Type	RO		UINT	49 for DEC3500

* Firmware versions before 1.4 do not support reading these reserved registers.

† Firmware versions before 1.4 do not support this parameter.

‡ Parameter is not writable in firmware versions before 1.4.

The Decision-Maker® 3500 controller reports the following abnormal values to express invalid, incorrect, or unsupported data in a given register.

Value (Hex)	Data Type	Unsigned Value (Decimal)	Signed Value (Decimal)	Description
0xFFC0	ANY	65472	-64	A Modbus register is not supported in the given application. Note: Not all unsupported registers will return the invalid register flag, some unsupported registers will return an exception response.
0x7FE0 — 0x7FFF	INT	32736 — 32767 Note: This return value is used when the value reported is a signed number. Any number larger than this will appear to be a very large negative number.	32736 — 32767	The register is supported, but the data in the register is unknown. This could indicate that the operating conditions render the data unreadable (such as sensors on an ECM engine when the ECM is not powered up), or indicate that the physical hardware to measure the quantity is either not present or replying with an out-of-range signal.
0xFFE0 — 0xFFFF	UINT	65504 — 65535	-32 — -1 Note: This return value is used when the value reported is an unsigned number. The number should not be interpreted as negative.	The register is supported, but the data in the register is unknown. This could indicate that the operating conditions render the data unreadable (such as sensors on an ECM engine when the ECM is not powered up), or indicate that the physical hardware to measure the quantity is either not present or replying with an out-of-range signal.
0x7FFFFFFE0 — 0x7FFFFFFF	DINT	2147483616 — 2147483647	2147483616 — 2147483647	The register is supported, but the data in the register is unknown. This could indicate that the operating conditions render the data unreadable (such as sensors on an ECM engine when the ECM is not powered up), or indicate that the physical hardware to measure the quantity is either not present or replying with an out-of-range signal.
0xFFFFFFE0 — 0xFFFFFFFF	UDINT	4294967264 — 4294967295	4294967264 — 4294967295	The register is supported, but the data in the register is unknown. This could indicate that the operating conditions render the data unreadable (such as sensors on an ECM engine when the ECM is not powered up), or indicate that the physical hardware to measure the quantity is either not present or replying with an out-of-range signal.

6.5 Inputs and Outputs Events

Note: See Figure 6-5 for more information on Event IDs that are identified as 1 in the table below.

Event ID	Parameter ID	FMI (Failure Mode Indicator)	Event ID/Parameter at Local Display	Level	Programmed Input	Programmed Output
			Protectives			
1	1100	Low	Engine Speed	Shutdown		D
		High	Engine Speed	Shutdown		D
1	1102	Shorted High	Engine Oil Pressure *	Warning	AD	D
		Shorted High	Engine Oil Pressure *	Shutdown	AD	D
		Shorted Low	Engine Oil Pressure *	Shutdown		D
		Low	Engine Oil Pressure	Warning	AD	D
		Low	Engine Oil Pressure	Shutdown	D	D
		Open Circuit	Engine Oil Pressure *	Shutdown		D
1	1103	Low	Engine Coolant Temperature *	Warning	AD	D
		Low	Engine Coolant Temperature *	Shutdown		D
		High	Engine Coolant Temperature *	Warning	AD	D
		High	Engine Coolant Temperature *	Shutdown	AD	D
		Open Circuit	Engine Coolant Temperature *	Shutdown		D
		Shorted High (3)	Engine Coolant Temperature *	Shutdown		D
		Shorted Low (4)	Engine Coolant Temperature *	Shutdown		D
1	1115	High	Lube Oil Temperature *	Warning	AD	
		High	Lube Oil Temperature *	Shutdown	D	
1	1105	Low	Engine Coolant Level	Shutdown	D	D
1	1106	Low	Engine Fuel Level	Warning	AD	D
		Low	Engine Fuel Level	Shutdown	D	D
		High	Engine Fuel Level	Warning	D	D
		Critically High	Engine Fuel Level	Warning	D	D
1	1110	Low	Fuel Pressure	Warning	AD	D
		Low	Fuel Pressure	Shutdown	AD	D
1	1107	Low	Gen Battery Voltage	Warning		D
		High	Gen Battery Voltage	Warning		D
6		Low	Cranking Voltage	Warning		D
1	1104	Low	Engine Oil Level	Warning	AD	D
		Low	Engine Oil Level	Shutdown	D	D
1	1334	Low	Generator Voltage L1-L2	Shutdown		D
		High	Generator Voltage L1-L2	Shutdown		D
1	1336	Low	Generator Voltage L2-L3	Shutdown		D
		High	Generator Voltage L2-L3	Shutdown		D
1	1338	Low	Generator Voltage L3-L1	Shutdown		D
		High	Generator Voltage L3-L1	Shutdown		D
1	1340	Low	Avg Gen Voltage L-L	Warning		D
		High	Avg Gen Voltage L-L	Warning		D
1	1358	Low	Generator Frequency	Warning		D
		High	Generator Frequency	Warning		D
		Low	Generator Frequency	Shutdown		D
		High	Generator Frequency	Shutdown		D
1	1374	Low	Total Power (Generator Total Real Power)	Warning		D
		High	Total Power (Generator Total Real Power)	Warning		D
		High	Total Power (Generator Total Real Power)	Shutdown		D
1	1323	Low	Total Reactive Power	Warning		D
1	1356	High	Avg Current	Warning		D
1	1601	Low	Maximum Alternator Current	Shutdown		D
1	1121	High	Intake Air Temperature	Warning		D
		High	Intake Air Temperature	Shutdown		D
1	1109	High	Fuel Temperature	Warning		D
		High	Fuel Temperature	Shutdown		D
1	1114	Low	Coolant Pressure	Warning	AD	D

Event ID	Parameter ID	FMI (Failure Mode Indicator)	Event ID/Parameter at Local Display	Level	Programmed Input	Programmed Output
30			AC Sensing Lost	Warning		D
30			AC Sensing Lost	Shutdown		D
20			Alternator Protection	Shutdown		D
23			Auxiliary Input	Warning	AD	D
23			Auxiliary Input	Shutdown	D	D
5			Battery Charger Fault	Warning	AD	D
75			Ecm Communication Loss	Shutdown		D
176			Ecm Model Mismatch	Shutdown		
19			Emergency Stop	Shutdown		D
35			Fuel Tank Leak	Warning	AD	D
35			Fuel Tank Leak	Shutdown	D	D
21			Ground Fault Input	Warning	AD	D
28			Locked Rotor	Shutdown		D
37			Electrical Metering Communication Loss	Shutdown		
4			Over Crank	Shutdown		D
29			Speed Sensor Fault	Warning		D
			Other Alerts			
11			Alarm Horn Silenced	Status		
12			Engine Cool Down Active	Notice		D
14			Engine Start Aid Active	Notice		D
125			Engine Started	Status		
126			Engine Stopped	Status		
8			Emergency Power System Supplying Load	Notice		D
9			Generator Running	Notice		D
3			Not In Auto	Warning		D
248			Option Board 2A Communication Loss	Notice		
249			Option Board 2B Communication Loss	Notice		
250			Option Board 2C Communication Loss	Notice		
16			Remote Start	Status		
235			Load Priority 1 Shed	Notice		D
236			Load Priority 2 Shed	Notice		D
237			Load Priority 3 Shed	Notice		D
238			Load Priority 4 Shed	Notice		D
239			Load Priority 5 Shed	Notice		D
240			Load Priority 6 Shed	Notice		D
255			Cabinet Intrusion Alarm	Warning	D	D
253			Reserve Oil Empty	Warning	D	D
410			Stopped By Generator Management	Status		D
379			Failure To Synchronize	Warning		D
1	4740	High	Fail To Open Delay	Warning		
1	4741	High	Fail To Close Delay	Warning		
1	4716	High	Max Close Attempts	Warning		
1	3851	Erroneous Data Received	Generator Management (Invalid Generator Management Enabled)	Warning		
1	4328	High	Trip To Shutdown Delay	Shutdown		
26			Run Relay Coil Overload	Shutdown		
27			Starter Relay Coil Overload	Shutdown		
1	1702	High	System Frequency	Warning		
		Low	System Frequency	Warning		
1	1700	High	System Voltage	Warning		
		Low	System Voltage	Warning		
1	1703	Erroneous Data Received	System Phase	Warning		

Event ID	Parameter ID	FMI (Failure Mode Indicator)	Event ID/Parameter at Local Display	Level	Programmed Input	Programmed Output
ECM Diagnostics						
32			Engine Derate Active	Warning		
33			Injector Wiring Fault	Warning		
26			Run Relay Coil Overload	Warning		
31			Sensor Supply Voltage	Warning		
29			Speed Sensor Fault	Warning		
27			Starter Relay Coil Overload	Warning		
34			Water In Fuel	Warning		
Notices Excluded From Display						
25			Common Fault	Notice		D
24			Common Warning	Notice		D
15			System Ready	Notice		D
228			Remote Start Command Issued	Notice		
231			Run Button Acknowledged	Notice		
312			Contactora	Notice		D
313			Close Breaker	Notice		D
403			Remove Breaker Trip	Notice		D
404			Standalone Operation	Status	D	
405			Load Enable	Status	D	
406			Baseload Mode	Status	D	
407			System Control Mode	Status	D	
408			System Sync Mode	Status	D	
409			Enable Trims	Status	D	

* Sensor dependent

Note: A = Analog, D = Digital

Figure 6-4 Input and Output Events

6.6 Failure Mode Indicator (FMI)

CriticallyHigh	0
CriticallyLow	1
Erratic	2
ShortedHigh	3
ShortedLow	4
OpenCircuit	5
GroundedCircuit	6
MechanicalSystemNotResponding	7
AbnormalFrequency	8
AbnormalUpdateRate	9
AbnormalRateOfChange	10
RootCauseUnknown	11
DeviceOutOfOrder	12
OutOfCalibration	13
SpecialInstructions	14
SlightlyHigh	15
High	16
SlightlyLow	17
Low	18
ErroneousDataReceived	19
Unavailable	28
Available	29
OK	30
NotApplicable	31

6.7 Severity Level

Status	1
Warning	2
Fault	3
Shutdown	4
Notice	5

6.8 Object ID

DEC3500 = 0
14 Relay Board = 1

6.9 Event ID 1

Decision-Maker® 3500 Controller				
Event ID	Level	FMI	Param ID	Text to display
1	4	16	1100	Overspeed Shutdown
1	4	18	1100	Underspeed Shutdown
1	2	18	1102	Low Oil Pressure Warning
1	4	18	1102	Low Oil Pressure Shutdown
1	2	3	1102	Shorted High Oil Pressure Warning
1	4	3	1102	Shorted High Oil Pressure Shutdown
1	4	4	1102	Shorted Low Oil Pressure Shutdown
1	4	5	1102	Open Circuit Oil Pressure Shutdown
1	2	18	1103	Low Coolant Temperature Warning
1	2	16	1103	High Coolant Temp Warning
1	4	16	1103	High Coolant Temp Shutdown
1	4	5	1103	No Coolant Temp Signal Shutdown
1	4	18	1103	Low Coolant Temperature Shutdown
1	4	3	1103	Shorted High Coolant Temperature Shutdown
1	4	4	1103	Shorted Low Coolant Temperature Shutdown
1	2	18	1104	Low Oil Level Warning
1	4	18	1104	Low Oil Level Shutdown
1	4	18	1105	Low Coolant Level Shutdown
1	2	18	1106	Low Fuel Warning
1	4	18	1106	Low Fuel Shutdown
1	2	16	1106	High Fuel Warning
1	2	0	1106	Critically High Fuel Warning
1	2	18	1107	Low Battery Voltage
1	2	16	1107	High Battery Voltage
1	2	16	1109	High Fuel Temperature Warning
1	4	16	1109	High Fuel Temperature Shutdown
1	2	18	1110	Low Fuel Pressure Warning
1	4	18	1110	Low Fuel Pressure Shutdown
1	2	18	1114	Low Coolant Pressure Warning
1	2	6	1115	High Oil Temperature Warning
1	4	16	1115	High Oil Temperature Shutdown
1	2	16	1121	High Intake Air Temperature Warning
1	4	16	1121	High Intake Air Temperature Shutdown
1	2	18	1323	Low Total Reactive Power Warning
1	4	18	1334	Under Voltage Shutdown (L1-L2)
1	4	16	1334	Over Voltage Shutdown (L1-L2)
1	4	18	1336	Under Voltage Shutdown (L2-L3)
1	4	16	1336	Over Voltage Shutdown (L2-L3)
1	4	18	1338	Under Voltage Shutdown (L3-L1)
1	4	16	1338	Over Voltage Shutdown (L3-L1)
1	2	18	1340	Under Avg. Voltage Warning (L-L)
1	2	16	1340	Over Avg. Voltage Warning (L-L)
1	2	16	1356	Over Avg. Current Warning
1	4	18	1358	Under Frequency Shutdown
1	4	16	1358	Over Frequency Shutdown
1	2	18	1358	Under Frequency Warning
1	2	16	1358	Over Frequency Warning
1	2	18	1374	Low Total Power Warning
1	2	16	1374	High Total Power Warning
1	4	16	1374	High Total Power Shutdown
1	4	18	1601	Low Maximum Alternator Current

Decision-Maker® 3500 Controller				
Event ID	Level	FMI	Param ID	Text to display
1	2	16	1700	High System Voltage Warning
1	2	18	1700	Low System Voltage Warning
1	2	16	1702	High System Frequency Warning
1	2	18	1702	Low System Frequency Warning
1	2	19	1703	Erroneous Data Received System Phase Warning
1	2	19	3851	Erroneous Data Received Generator Management Warning
1	4	16	4328	High Trip To Shutdown Delay Shutdown
1	2	16	4716	High Max Close Attempts Warning
1	2	16	4740	High Fail To Open Delay Warning
1	2	16	4741	High Fail To Close Delay Warning

Figure 6-5 Event ID 1, Parameter Value Abnormal, Decision-Maker® 3500 Controller

Notes

Section 7 Decision-Maker 6000 Generator Set Controller

7.1 Specifications

The Decision-Maker® 6000 controller's Modbus® communication capability:

- Supports industry-standard Modbus® RTU protocol.
- Can use Modbus® TCP protocol with the addition of a Modbus/Ethernet converter.
- Connects to a Modbus® master singly over an RS-232 line.
- Uses RS-485 connections to connect to a Modbus® master singly or over an RS-485 network.
- Connects to an Ethernet network using a Modbus/Ethernet converter.
- Can operate as an RS-232 to RS-485 converter.
- Uses standard baud rates of 9600 or 19200.

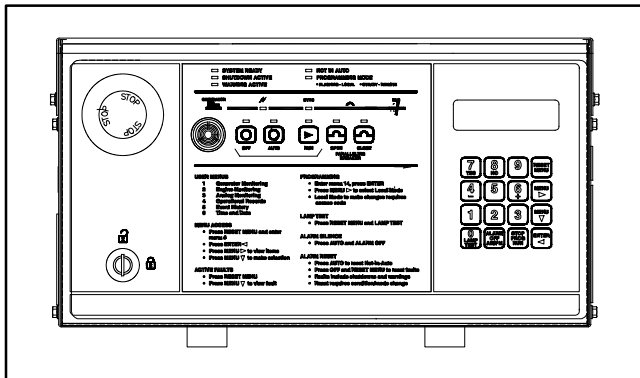
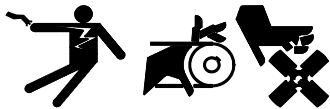

Figure 7-1 Decision-Maker® 6000 Controller

7.2 Hardware Connections

⚠ WARNING



**Accidental starting.
Can cause severe injury or death.**

Disconnect the battery cables before working on the generator set. Remove the negative (-) lead first when disconnecting the battery. Reconnect the negative (-) lead last when reconnecting the battery.

Disabling the generator set. Accidental starting can cause severe injury or death. Before working on the generator set or connected equipment, disable the generator set as follows: (1) Move the generator set master switch to the OFF position. (2) Disconnect the power to the battery charger. (3) Remove the battery cables, negative (-) lead first. Reconnect the negative (-) lead last when reconnecting the battery. Follow these precautions to prevent starting of the generator set by an automatic transfer switch, remote start/stop switch, or engine start command from a remote computer.

Plan the connections and refer to Figure 1-1 through Figure 1-4 to identify the cables needed. Use either an RS-232 cable or the supplied RS-485 connector with Belden #9841 or equivalent cable for a single connection. Use the RS-485 connector and Belden #9841 or equivalent cable to connect devices in a network. Attach the RS-485 connectors as shown in Figure 7-2. Use the termination resistor on the last device in the network.

Circuit isolation is recommended for installations that may be exposed to electrical noise. See Appendix B, Noise and Wiring Practices.

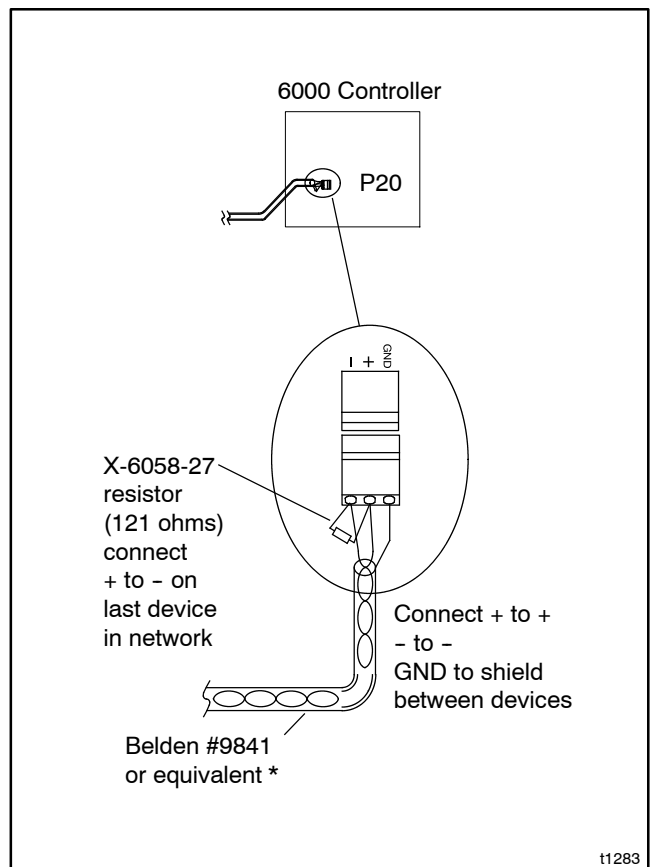

Figure 7-2 RS-485 Connector Details

Use the following procedure to connect the hardware. Observe the safety precautions.

Controller Connection Procedure

1. Press the OFF button on the Decision-Maker 6000.
2. Disconnect the power to the battery charger, if equipped.
3. Disconnect the generator set engine starting battery(ies), negative (-) lead first.
4. Turn off and disconnect the power to all devices in the system.
5. Open the enclosure and locate the connection ports as shown in Figure 7-3 and Figure 7-4.
6. Make connections to the desired controller port(s). For RS-232 connections, use connector P18. For RS-485 connections, use the Modbus® RS-485 connector, P20 (connectors P19 and P21 are used for other applications).
7. Close the controller enclosure.
8. Verify that the Decision-Maker 6000 is off.

9. Reconnect the generator set engine starting battery, negative (-) lead last.
10. Reconnect power to the battery charger, if equipped.

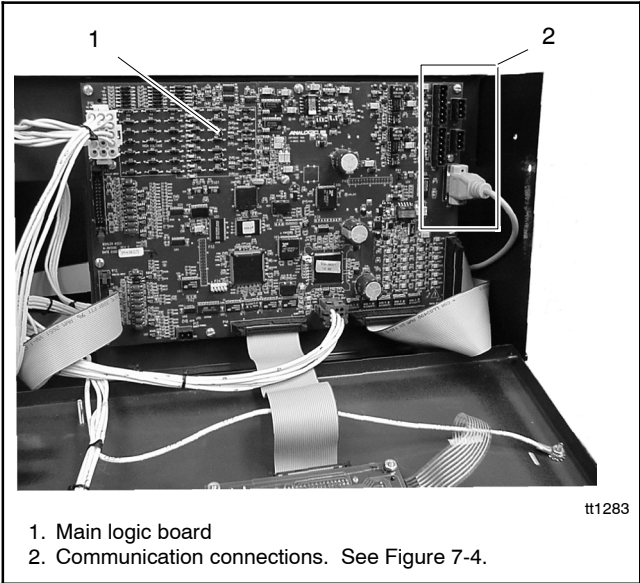

Figure 7-3 Communication Port Locations for Decision-Maker 6000 Generator Set Controller

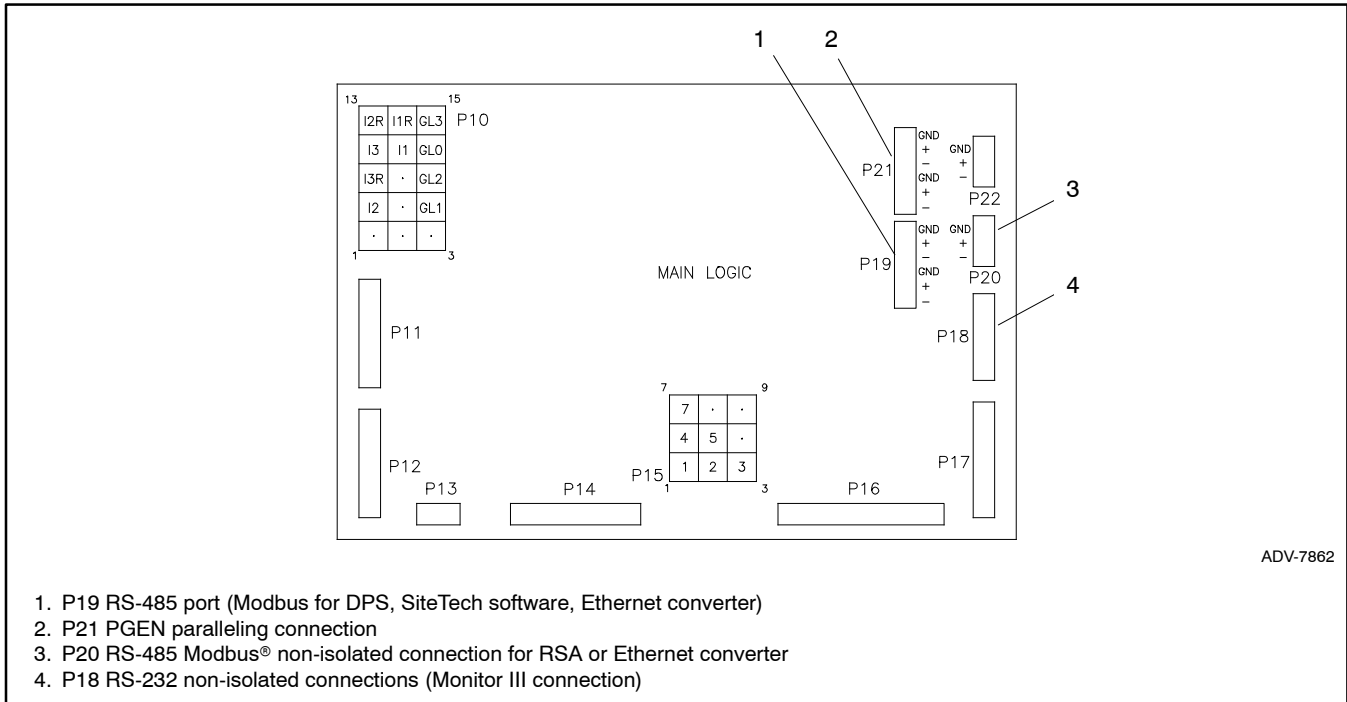

Figure 7-4 Communication Connections Pin Identification

7.3 Controller Setup

After connecting the hardware, set up the controller. Enter the communication settings shown in the procedure below. Refer to the controller operation manual for detailed instructions on how to enter settings through the controller keypad.

Note: Changing the programming mode requires entering the generator set controller access code. Refer to the controller operation manual for more information.

Controller Setup Procedure

1. Go to Menu 14—Programming Mode using the controller keypad. Enter the local programming mode to allow changes to the controller communication settings.
2. Enter the controller access code when prompted by the controller.
3. Go to Menu 13—Communications.
4. Use the MENU arrow buttons to move to the Protocol Modbus 0 heading.
5. Enter Yes at the Modbus Online Y/N display.
6. Choose the connection type. Choose Converter and proceed to step 8 if the controller is converting RS-232 to RS-485. Otherwise, choose Single and proceed to step 7.

Note: The controller automatically selects RS-232 for the primary port if Converter is chosen for the connection type.

7. Choose RS-232 or RS-485 for the primary port, which is the port connected to the Modbus® master.
8. Enter the network address of the controller. Enter 1 (one) for a single connection.
Note: Use a unique network address for each unit. Use numbers between 1 and 246. Do not use 0 (zero).
9. Select the baud rate. Choose the same baud rate for the Modbus® master, modems, and connected devices.
10. Go to Menu 14—Programming Mode again. Choose either remote programming mode, local programming mode, or programming mode off as described below:
 - a. To allow the Modbus® master to read and write to the controller, choose Remote; *or*
 - b. To allow only monitoring through the Modbus® connections but local programming through the controller keypad, choose Local; *or*
 - c. To turn the programming mode off, allowing no controller programming from either the Modbus® master or the local keypad, choose Off.
11. Enter the controller access code when prompted by the controller.

7.4 Modbus Registers

This section contains Modbus® registers for the Decision-Maker 6000 controller. Refer to Section 1.3 for definitions of terms and symbols used in the register tables.

Time delays, setpoints, inputs and outputs, and other user-defined parameters are entered through the controller keypad or SiteTech software. Refer to the operation manuals for the controller or software for instructions. See the List of Related Materials for document part numbers.

The system event stack registers 41500–41515 contain the status (active or inactive) of fault warnings and shutdowns, inputs, outputs, and MDEC/ADEC alarms. See Section 7.4.6.

The event history registers 40871–41270 contain the time and date information for the last 100 events. See Section 7.4.6 for event message codes.

7.4.1 Guide to the Register Map

Description	Registers
Monitoring	40001–40083
Electrical Output	40001–40032
Engine Status	40033–40060
Analog Input Status	40061–40076
Digital Input Status	40077–40078
Controller Status	40079–40083
Maintenance	40084–40112
Time/Date	40113–40115
Time Delay Settings	40116–40124
Settings and Setpoints	40125–40146
Factory Setup	40147–40226
Digital Input Setup	40227–40499
Analog Input Setup	40500–40739
Remapped Registers *	40740–40837
Relay Driver Output Status (see Section 7.4.4)	40838–40839
Relay Driver Output Setup	40840–40870
Event History	40871–41270
Customer-Defined Character Strings	41271–41295
Reserved and Write-Only Registers	41296–41305
Remote Functions	41306–41413
Reserved for Factory Use	41314–41499
System Event Stack (status of fault warnings and shutdowns, inputs, outputs, and MDEC alarms; see Section 7.4.6.)	41500–41515
Reserved for Wireless Monitor	41516–41536
Reserved	41537–41549
Defined Common Faults (Define/Inspect)	41550–41805
Reserved	41806–49998
Device ID	49999
* Registers 40740–40837 have been mapped to 41550–41647 (Defined Common Faults). See Section 7.4.3.	

7.4.2 Modbus Registers

Register	Data Description	Access	Data Type	Range/Units/Notes
40001	L1 - L2 Voltage	RO	WORD	Volts AC
40002	L2 - L3 Voltage	RO	WORD	Volts AC
40003	L3 - L1 Voltage	RO	WORD	Volts AC
40004	L1 - L0 Voltage	RO	WORD	Volts AC
40005	L2 - L0 Voltage	RO	WORD	Volts AC
40006	L3 - L0 Voltage	RO	WORD	Volts AC
40007	L1 Current	RO	WORD	Amps AC
40008	L2 Current	RO	WORD	Amps AC
40009	L3 Current	RO	WORD	Amps AC
40010	Frequency	RO	WORD	Hz X 100
40011	Total kW	RO	WORD	kW
40012	Percent of Rated kW	RO	WORD	% Rated kW
40013	Total Power Factor	RO	SWORD	PF X 100 (SIGNED)
40014	L1 kW	RO	WORD	kW
40015	L1 Power Factor	RO	SWORD	PF X 100 (SIGNED)
40016	L2 kW	RO	WORD	kW
40017	L2 Power Factor	RO	SWORD	PF X 100 (SIGNED)
40018	L3 kW	RO	WORD	kW
40019	L3 Power Factor	RO	SWORD	PF X 100 (SIGNED)
40020	Total kVAR	RO	SWORD	kVAR (SIGNED)
40021	L1 kVAR	RO	SWORD	kVAR (SIGNED)
40022	L2 kVAR	RO	SWORD	kVAR (SIGNED)
40023	L3 kVAR	RO	SWORD	kVAR (SIGNED)
40024	Total kVA	RO	WORD	kVA
40025	L1 kVA	RO	WORD	kVA
40026	L2 kVA	RO	WORD	kVA
40027	L3 kVA	RO	WORD	kVA
40028	Current Lead/Lag	RO	WORD	Bits 0-1 Total Current - Leading = 10 Lagging = 01 Bits 2-3 L1 Current - Leading = 10 Lagging = 01 Bits 4-5 L2 Current - Leading = 10 Lagging = 01 Bits 6-7 L3 Current - Leading = 10 Lagging = 01
40029	Reserved For Future Use	RO	WORD	Returns 0 (zero).
40030	Reserved For Future Use	RO	WORD	Returns 0 (zero).
40031	Reserved For Future Use	RO	WORD	Returns 0 (zero).
40032	Reserved For Future Use	RO	WORD	Returns 0 (zero).
40033	Oil Pressure*	RO	WORD	kPa/psi
40034	Coolant Temperature*	RO	SWORD	Degrees C/Degrees F
40035	Engine Speed*	RO	WORD	RPM
40036	Local Battery Voltage*	RO	WORD	Volts DC X 10
40037	Fuel Pressure*	RO	WORD	kPa/psi DDEC/MDEC/ADEC only
40038	Fuel Temperature*	RO	SWORD	Degrees C/Degrees F DDEC/MDEC/ADEC only
40039	Fuel Rate*	RO	WORD	Liters/Hour X 100 or Gallons/Hour X 100 DDEC only
40040	Used Last Run*	RO	WORD	Liters/Gallons DDEC only
40041	Coolant Pressure*	RO	WORD	kPa/psi DDEC only
40042	Coolant Level*	RO	WORD	% X 10 DDEC only

*0x7FD6 = data unavailable. 0x7FFF = data is out of range.

Register	Data Description	Access	Data Type	Range/Units/Notes
40043	Lube Oil Temperature*	RO	SWORD	Degrees C/Degrees F DDEC/MDEC/ADEC only
40044	Oil Level*	RO	WORD	% X 10 DDEC only
40045	Crankcase Pressure*	RO	WORD	kPa/psi DDEC only
40046	Ambient Temperature*	RO	SWORD	Degrees C/Degrees F DDEC only
40047	ECM Battery Voltage*	RO	WORD	Volts DC X 10 DDEC/MDEC/ADEC only
40048	ECM Status	RO	WORD	0 = DDEC-Equipped, 1 = Non-ECM, 2 = MDEC/ADEC-Equipped
40049	Intake Air Temperature*	RO	SWORD	Degrees C/Degrees F MDEC/ADEC only
40050	Intake Air Pressure*	RO	WORD	Degrees C/Degrees F MDEC/ADEC only
40051	MDEC/ADEC Fault Codes*	RO	WORD	Numeric Fault Code MDEC/ADEC only
40052	Reserved For Future Use	RO	WORD	Returns 0 (zero).
40053	Reserved For Future Use	RO	WORD	Returns 0 (zero).
40054	Reserved For Future Use	RO	WORD	Mapped to register 41500 for compatibility with earlier controller application code versions. Note: Code versions 2.10 and higher use more registers for the Event Stack than previous versions.
40055	Reserved For Future Use	RO	WORD	Returns 0 (zero).
40056	Reserved For Future Use	RO	WORD	Returns 0 (zero).
40057	Reserved For Future Use	RO	WORD	Returns 0 (zero).
40058	Reserved For Future Use	RO	WORD	Returns 0 (zero).
40059	Reserved For Future Use	RO	WORD	Returns 0 (zero).
40060	Reserved For Future Use	RO	WORD	Returns 0 (zero).
40061	Analog Input 00 (Battery Voltage)*	RO	WORD	Volts DC
40062	Analog Input 01*	RO	WORD	User-defined and calibrated through the 6000 controller. See the controller operation manual.
40063	Analog Input 02*	RO	WORD	
40064	Analog Input 03*	RO	WORD	
40065	Analog Input 04*	RO	WORD	
40066	Analog Input 05*	RO	WORD	
40067	Analog Input 06*	RO	WORD	
40068	Analog Input 07*	RO	WORD	
40069	Reserved For Additional Input	RO	WORD	
40070	Reserved For Additional Input	RO	WORD	
40071	Reserved For Additional Input	RO	WORD	
40072	Reserved For Additional Input	RO	WORD	
40073	Reserved For Additional Input	RO	WORD	
40074	Reserved For Additional Input	RO	WORD	
40075	Reserved For Additional Input	RO	WORD	
40076	Reserved For Additional Input	RO	WORD	

*0x7FD6 = data unavailable. 0x7FFF = data is out of range.

Register	Data Description	Access	Data Type	Range/Units/Notes
40077-40078	Digital Input Status/Option Flags	RO	2 WORDS	Word #1 Digital Inputs 0-15: Bit 0 Remote start contacts Bit 1 Emergency stop Bit 2 Low coolant level Bit 3 Digital Input #1 Bit 4 Digital Input #2 Bit 5 Digital Input #3 Bit 6 Digital Input #4 Bit 7 Digital Input #5 Bit 8 Digital Input #6 Bit 9 Digital Input #7 Bit 10 Digital Input #8 Bit 11 Digital Input #9 Bit 12 Digital Input #10 Bit 13 Digital Input #11 Bit 14 Digital Input #12 Bit 15 Digital Input #13
40077-40078, cont.	Digital Input Status/Option Flags	RO	2 WORDS	Word #2: Bit 0 Digital Input #14 Bit 1 Digital Input #15 Bit 2 Digital Input #16 Bit 3 Digital Input #17 Bit 4 Digital Input #18 Bit 5 Digital Input #19 Bit 6 Digital Input #20 Bit 7 Digital Input #21 Bit 8 DDEC Flag Bit 9 MDEC/ADEC Flag Bit 10 Tier1 Flag Bit 11 Waukesha Flag Bits 12-15 Unused Input Is high/option enabled if bit is set. Digital inputs are user-defined through the controller or Monitor III software. See the related operation manual.
40079	Master Switch Position	RO	WORD	0 = Error, 1 = Auto, 2 = Off, 3 = Run
40080	Programming Mode Status	RO	WORD	1 = Off, 2 = Local, 3 = Remote
40081	Reserved For Future Use	RO	WORD	Returns 0 (zero).
40082	Reserved For Future Use	RO	WORD	Returns 0 (zero).
40083	Reserved For Future Use	RO	WORD	Returns 0 (zero).
40084	Total Number of Starts	RO	WORD	Starts
40085	Total Run Time Hrs	RO	LONG	HRS X 100 (LSW FIRST)
40087	Total Run Time Loaded Hrs	RO	LONG	HRS X 100 (LSW FIRST)
40089	Total Run Time Unloaded Hrs	RO	LONG	HRS X 100 (LSW FIRST)
40091	Total Run Time kW Hrs	RO	LONG	kW Hrs (LSW First)
40093	RTSM Total Hrs	RO	LONG	HRS X 100 (LSW FIRST)
40095	RTSM Loaded Hrs	RO	LONG	HRS X 100 (LSW FIRST)
40097	RTSM Unloaded Hrs	RO	LONG	HRS X 100 (LSW FIRST)
40099	RTSM kW Hrs	RO	LONG	kW Hrs (LSW FIRST)
40101	Last Maintenance Date	RO	2 WORDS	Day Month - Year
40103	Operating Days Since Maint.	RO	WORD	Days
40104	Number of Starts Since Maint.	RO	WORD	Starts
40105	Last Start Date	RO	2 WORDS	Day Month - Year
40107	Last Start Time	RO	WORD	Hr Min
40108	Last Run Length	RO	WORD	Hrs X 100
40109	Last Run Loaded	RO	WORD	0 = Unloaded, 1 = Loaded

*0x7FD6 = data unavailable. 0x7FFF = data is out of range.

Register	Data Description	Access	Data Type	Range/Units/Notes
40110	Timed Run Time (Hr:Min)	RW	WORD	Hr Min
40111	Timed Run Remaining (Hr:Min)	RO	WORD	Hr Min
40112	Is Timed Run Active	RO	WORD	1 = True, 0 = False
40113	Current Date	RW	2 WORDS	Day Month - 2 Digit Year Day of Week (0=Sunday)
40115	Current Time (24 Hr Clock)	RW	WORD (Hr Min)	Hr Min
40116	Time Delay Engine Start	RW	WORD	Min Sec
40117	Time Delay Starting Aid	RW	WORD	Min Sec
40118	Time Delay Crank On	RW	WORD	Min Sec
40119	Time Delay Crank Pause	RW	WORD	Min Sec
40120	Time Delay Engine Cooldown	RW	WORD	Min Sec
40121	Time Delay Crank Cycles	RW	WORD	Cycles
40122	Time Delay Overvoltage	RW	WORD	Min Sec
40123	Time Delay Undervoltage	RW	WORD	Min Sec
40124	Time Delay Load Shed kW	RW	WORD	Min Sec
40125	Operating Mode	RW	WORD	Bits 0-1: Operating Mode 1=Standby, 2=Prime Power Bit 2: Unused Bit 3: MDEC/ADEC DSC Mode 1 = Enabled, 0 = Disabled Bit 4: MDEC/ADEC VSG Mode 1 =Enabled, 0 = Disabled Bits 5-7: Temp Sensor Type
40126	System Voltage	RW	WORD	Volts AC
40127	System Frequency	RW	WORD	Hz
40128	System Phase	RW	WORD	1 = 3 Phase Delta, 2 = 3 Phase Wye, 3 = Single Phase
40129	kW Rating	RW	WORD	kW
40130	Load Shed Output	RW	WORD	% of kW RATING
40131	Overvoltage	RW	WORD	% of System Voltage
40132	Undervoltage	RW	WORD	% of System Voltage
40133	Overfrequency	RW	WORD	% of System Frequency
40134	Underfrequency	RW	WORD	% of System Frequency
40135	Overspeed	RW	WORD	Hz
40136	Battery Voltage	RW	WORD	Volts DC X 10
40137	Lo Battery Voltage	RW	WORD	Volts DC X 10
40138	Hi Battery Voltage	RW	WORD	Volts DC X 10
40139	Metric Units	RW	WORD	1 = True, 0 = False
40140	NFPA 110 Defaults Enabled	RW	WORD	1 = True, 0 = False
40141	Rated Current	RO	WORD	Amps AC
40142	Cooldown Temperature Override	RW	WORD	1 = True, 0 = False
40143	Reserved For Future Use	RO	WORD	Returns 0 (zero).
40144	Reserved For Future Use	RO	WORD	Returns 0 (zero).
40145	Reserved For Future Use	RO	WORD	Returns 0 (zero).
40146	Reserved For Future Use	RO	WORD	Returns 0 (zero).
40147	Final Assembly Date	RO	2 WORDS	Day Month - Year
40149	Final Assembly Clock No.	RO	LONG	99999 Max (LSW FIRST)
40151	Total Operating Days	RO	WORD	Days
40152	Model No.	RO	13 WORDS	26 Character String

*0x7FD6 = data unavailable. 0x7FFF = data is out of range.

Register	Data Description	Access	Data Type	Range/Units/Notes
40165	Spec. No.	RO	8 WORDS	16 Character String
40173	Genset Serial No.	RO	10 WORDS	20 Character String
40183	Alternator Part No.	RO	10 WORDS	20 Character String
40193	Engine Part No.	RO	10 WORDS	20 Character String
40203	Control No.	RO	LONG	(LSW FIRST)
40205	Code Version	RO	3 WORDS	6 Character String
40208	Setup Lock	RO	WORD	1 = Locked, 0 = Unlocked
40209	Engine Model No.	RO	4 WORDS	8 Character String ECM only
40213	Engine Serial No.	RO	5 WORDS	10 Character String ECM only
40218	Unit No.	RO	5 WORDS	10 Character String ECM only
40223	ECM Serial No.	RO	4 WORDS	8 Character String ECM only
Digital Inputs 1-21 Setup (for status see 40077-40079):				
40227	Digital Input 01	RW	13 WORDS PER INPUT	<p>Word 1: Enabled Function ID Word 2: Inhibit Time (Min Sec) Word 3: Delay Time (Min Sec) Word 4-13: 10 Words for 20 Character Description String</p> <p>Refer to Section 7.4.7, Digital Auxiliary Input Functions, for descriptions and codes. See the controller operation manual for factory-reserved and user-selectable inputs for various applications.</p>
40240	Digital Input 02			
40253	Digital Input 03			
40266	Digital Input 04			
40279	Digital Input 05			
40292	Digital Input 06			
40305	Digital Input 07			
40318	Digital Input 08			
40331	Digital Input 09			
40344	Digital Input 10			
40357	Digital Input 11			
40370	Digital Input 12			
40383	Digital Input 13			
40396	Digital Input 14			
40409	Digital Input 15			
40422	Digital Input 16			
40435	Digital Input 17			
40448	Digital Input 18			
40461	Digital Input 19			
40474	Digital Input 20			
40487	Digital Input 21			
Note: Cannot read past end of block				
Analog Input Setup (for status see registers 40061-40068)				
40500	Analog Input 01	RW	16 WORDS PER INPUT	Refer to the controller operation manual for identification of user inputs and factory-reserved inputs for specific applications.
40516	Analog Input 02			
40532	Analog Input 03			
40548	Analog Input 04			
40564	Analog Input 05			
40580	Analog Input 06			
40596	Analog Input 07			
Note: Cannot read past end of block				
*0x7FD6 = data unavailable. 0x7FFF = data is out of range.				

Register	Data Description	Access	Data Type	Range/Units/Notes
Analog Inputs 8-15 Setup				
40612	Reserved For Non-ECM	RO	16 WORDS PER INPUT	
40628				
40644				
40660				
40676				
40692				
40708				
40724				
Note: Cannot read past end of block				
Registers 40740-40837 have been mapped to 41550-41647.				
Define/Inspect RDO Status (2 WORDS). See Section 7.4.4.				
40838	RDO Status: RDO1 - RDO16	RO†	WORD	Output Is High If Individual Bit Is Set. Bit 0 = RDO 1
40839	RDO Status: RDO17 - RDO31	RO†	WORD	Output Is High If Individual Bit Is Set. Bit 0 = RDO 17
† Software-controlled RDOs are RW.				
Note: Cannot read past end of block				
Define/Inspect RDOs (RW, 1 WORD per RDO). See Section 7.4.6				
40840	Relay Driver Output 01	RW	WORD	Selection Setpoint
40841	Relay Driver Output 02	RW	WORD	
40842	Relay Driver Output 03	RW	WORD	
40843	Relay Driver Output 04	RW	WORD	
40844	Relay Driver Output 05	RW	WORD	
40845	Relay Driver Output 06	RW	WORD	
40846	Relay Driver Output 07	RW	WORD	
40847	Relay Driver Output 08	RW	WORD	
40848	Relay Driver Output 09	RW	WORD	
40849	Relay Driver Output 10	RW	WORD	
40850	Relay Driver Output 11	RW	WORD	
40851	Relay Driver Output 12	RW	WORD	
40852	Relay Driver Output 13	RW	WORD	
40853	Relay Driver Output 14	RW	WORD	
40854	Relay Driver Output 15	RW	WORD	
40855	Relay Driver Output 16	RW	WORD	
40856	Relay Driver Output 17	RW	WORD	
40857	Relay Driver Output 18	RW	WORD	
40858	Relay Driver Output 19	RW	WORD	
40859	Relay Driver Output 20	RW	WORD	
40860	Relay Driver Output 21	RW	WORD	
40861	Relay Driver Output 22	RW	WORD	
40862	Relay Driver Output 23	RW	WORD	
40863	Relay Driver Output 24	RW	WORD	
*0x7FD6 = data unavailable. 0x7FFF = data is out of range.				

Register	Data Description	Access	Data Type	Range/Units/Notes
40864	Relay Driver Output 25	RW	WORD	Function Setpoint
40865	Relay Driver Output 26	RW	WORD	Function uses the event codes in Section 7.4.6. Setpoints are for analog inputs only; otherwise setpoint=0.
40866	Relay Driver Output 27	RW	WORD	
40867	Relay Driver Output 28	RW	WORD	
40868	Relay Driver Output 29	RW	WORD	
40869	Relay Driver Output 30	RW	WORD	
40870	Relay Driver Output 31	RW	WORD	
Note: Cannot read past end of block				
Event History. See Section 7.4.6 for event codes.				
40871-40910	Event History - Page 1 (1-10)	RO	40 WORDS	10 events, 4 words each: Event Code Setpoint Hr Min Day Month Year See Section 7.4.6 for event codes. Setpoints are for analog inputs only; otherwise setpoint=0 Note: Message code = 0xFFat end of history
40911-40950	Event History - Page 2 (11-20)	RO	40 WORDS	
40951-40990	Event History - Page 3 (21-30)	RO	40 WORDS	
40991-41030	Event History - Page 4 (31-40)	RO	40 WORDS	
41031-41070	Event History - Page 5 (41-50)	RO	40 WORDS	
41071-41110	Event History - Page 6 (51-60)	RO	40 WORDS	
41111-41150	Event History - Page 7 (61-70)	RO	40 WORDS	
41151-41190	Event History - Page 8 (71-80)	RO	40 WORDS	
41191-41230	Event History - Page 9 (81-90)	RO	40 WORDS	
41231-41270	Event History - Page 10 (91-100)	RO	40 WORDS	
Note: Cannot read past end of block.				
Customer-Defined Character Strings (defined through Monitor software)				
41271	Designation	RW	5 WORDS	9 Character String
41276	Load	RW	10 WORDS	20 Character String
41286	Location	RW	10 WORDS	20 Character String
Note: Cannot read past end of block.				
41296	Reserved for future use	RO	WORD	Returns 0 (zero).
41297	Reserved for future use	RO	WORD	Returns 0 (zero).
41298	Reserved for future use	RO	WORD	Returns 0 (zero).
41299	Reserved for future use	RO	WORD	Returns 0 (zero).
41300	Reserved for future use	RO	WORD	Returns 0 (zero).
41301	Reserved for future use	RO	WORD	Returns 0 (zero).
41302	Reserved for future use	RO	WORD	Returns 0 (zero).
41303	Reserved for future use	RO	WORD	Returns 0 (zero).
41304	Reserved for future use	RO	WORD	Returns 0 (zero).
41305	Reserved for future use	RO	WORD	Returns 0 (zero).
Note: Cannot Read Past End of Block				
*0x7FD6 = data unavailable. 0x7FFF = data is out of range.				

Register	Data Description	Access	Data Type	Range/Units/Notes
Remote Functions				
41306	Start Timed Run	WO	WORD	1 = Start, 0 = No Start
41307	Stop Timed Run	WO	WORD	1 = Stop, 0 = No Stop
41308	Reset Maintenance Records	WO	WORD	1 = Reset, 0 = No Reset
41309	Remote Fault Reset	WO	WORD	1 = Reset, 0 = No Reset
41310	Reserved for future use	RO	WORD	Returns 0 (zero).
41311	Reserved for future use	RO	WORD	Returns 0 (zero).
41312	Reserved for future use	RO	WORD	Returns 0 (zero).
41313	Reserved for future use	RO	WORD	Returns 0 (zero).
41314-41499	Reserved for factory use			
System Event Stack (must be read as 16 register block). See Sections 7.4.5 and 7.4.6.				
41500	System Events 0-15 Word #1	RO	16 WORDS	System event status. 0=not active 1=active Each bit corresponds to a different event code. See Sections 7.4.5 and 7.4.6.
41501	System Events 16-31 Word #2			
41502	System Events 32-47 Word #3			
41503	System Events 48-63 Word #4			
41504	System Events 64-79 Word #5			
41505	System Events 80-95 Word #6			
41506	System Events 96-111 Word #7			
41507	System Events 112-127 Word #8			
41508	System Events 128-143 Word #9			
41509	System Events 144-159 Word #10			
41510	System Events 160-175 Word #11			
41511	System Events 176-191 Word #12			
41512	System Events 192-207 Word #13			
41513	System Events 208-223 Word #14			
41514	System Events 224-239 Word #15			
41515	System Events 240-255 Word #16			
Note: Cannot Read Past End of Block.				
41516-41536	Reserved	RO	WORD	Reserved for the Wireless Monitor
41537-41549	Not used	RO	WORD	Returns illegal address
*0x7FD6 = data unavailable. 0x7FFF = data is out of range.				

Register	Data Description	Access	Data Type	Range/Units/Notes
Define/Inspect Defined Common Faults:				
41550	Emergency Stop	RW	WORD	Selected Setpoint The selected byte indicates whether a given fault has been assigned to the defined common fault: 0=not assigned to the defined common fault; 1=assigned to the defined common fault. The setpoint byte indicates the setpoint value for that item.
41551	Overspeed			
41552	Overcrank			
41553	High Coolant Temperature Shutdown			
41554	Oil Pressure Shutdown			
41555	Low Coolant Temperature Warning (ECM only)			
41556	Low Fuel			
41557	High Coolant Temperature Warning			
41558	Oil Pressure Warning			
41559	Master Not In Auto			
41560	NFPA 110 Fault			
41561	Low Battery Voltage			
41562	High Battery Voltage			
41563	Battery Charger Fault			
41564	System Ready			
41565	Loss of ECM Comm (ECM only)			
41566	No Oil Pressure Signal			
41567	High Oil Temperature Shutdown			
41568	No Coolant Temperature Signal			
41569	Low Coolant Level			
41570	Speed Sensor Fault			
41571	Locked Rotor			
41572	Master Switch Error			
41573	Master Switch Open			
41574	Master Switch Off			
41575	AC Sensing Loss	RW	WORD	Selected Setpoint The selected byte indicates whether a given fault has been assigned to the defined common fault: 0=not assigned to the defined common fault; 1=assigned to the defined common fault. The setpoint byte indicates the setpoint value for that item.
41576	Over Voltage			
41577	Under Voltage			
41578	Weak Battery			
41579	Over Frequency			
41580	Under Frequency			
41581	Load Shed kW Overload	RW	WORD	Selected Setpoint
41582	Load Shed kW Under Frequency			
41583	Over Current Warning			
41584	EPS Supplying Load			
41585	Internal Fault			
*0x7FD6 = data unavailable. 0x7FFF = data is out of range.				

Register	Data Description	Access	Data Type	Range/Units/Notes
41586	Engine Cooldown Delay	RW	WORD	Selected Setpoint
41587	Engine Start Delay			
41588	Starting Aid			
41589	Generator Running			
41590	Air Damper Control			
41591	Ground Fault			
41592	EEPROM Write Failure			
41593	Critical Overvoltage			
41594	Alternator Protect Shutdown			
41595	Air Damper Indicator			
41596	Digital Input 01	RW	WORD	Note: Analog and digital inputs are user-defined through the controller or using Monitor III or SiteTech software. See the related operation manual.
41597	Digital Input 02			
41598	Digital Input 03			
41599	Digital Input 04			
41600	Digital Input 05			
41601	Digital Input 06			
41602	Digital Input 07			
41603	Digital Input 08			
41604	Digital Input 09			
41605	Digital Input 10			
41606	Digital Input 11			
41607	Digital Input 12			
41608	Digital Input 13			
41609	Digital Input 14			
41610	Digital Input 15			
41611	Digital Input 16			
41612	Digital Input 17			
41613	Digital Input 18			
41614	Digital Input 19			
41615	Digital Input 20			
41616	Digital Input 21			
41617	Analog Input 01			
41618	Analog Input 02			
41619	Analog Input 03			
41620	Analog Input 04			
41621	Analog Input 05			
41622	Analog Input 06			
41623	Analog Input 07			
41624	Reserved for additional input	RW	WORD	
41625	Reserved for additional input			
41626	Reserved for additional input			
41627	Reserved for additional input			

*0x7FD6 = data unavailable. 0x7FFF = data is out of range.

Register	Data Description	Access	Data Type	Range/Units/Notes
Define/Inspect Defined Common Faults, continued:				
41628	Reserved for additional input	RW	WORD	
41629	Reserved for additional input			
41630	Reserved for additional input			
41631	Reserved for additional input			
41632	Defined Common Fault			
41633	Software Controlled RDO#1	RW	WORD	Selected Setpoint
41634	Software Controlled RDO#2			
41635	Software Controlled RDO#3			
41636	Software Controlled RDO#4			
41637-41648	<i>Reserved for factory use</i>			
41649	Genset Parameter Warning	RW	WORD	Selected Setpoint
41650	Genset S/N Mismatch Warning			
41651	Genset S/N Mismatch Shutdown			
41652	<i>Reserved for factory use</i>	RW	WORD	Switchgear applications only. Cannot be defined as common fault or assigned as RDO, but can be referenced in event stack/log.
41653	Protective Relay Overvoltage			
41654	Protective Relay Under Voltage			
41655	Protective Relay Overfrequency			
41656	Protective Relay Underfrequency			
41657	Protective Relay Reverse Power			
41658	Protective Relay Over Power			
41659	Protective Relay Loss of Field			
41660	Protective Relay Overcurrent Vr			
41661	Reverse Power Shutdown	RW	WORD	Switchgear applications only
41662	Over Power Shutdown			
41663	Loss of Field Shutdown			
41664	Over Current Shutdown			
41665	Common Protective Relay Output	RW	WORD	Switchgear applications only. Cannot be defined as common fault, but can be assigned as RDO and referenced in event stack/log.
41666	In Synch	RW	WORD	Switchgear applications only.
41667	Breaker Trip			
41668	Fuel Valve Relay	RW	WORD	Waukesha only.
41669	Pre Lube Relay			
41670	Air -Fuel Module Start			
41671	Oil Temperature Loss of Signal			
41672	High Oil Temperature Warning			
41673	Intake Air Temperature Loss of Signal			
41674	High Intake Air Temperature Warning			
41675	High Intake Air Temperature Shutdown			

*0x7FD6 = data unavailable. 0x7FFF = data is out of range.

Register	Data Description	Access	Data Type	Range/Units/Notes
41676	MDEC/ADEC Yellow Alarm	RW	WORD	MDEC/ADEC only.
41677	MDEC/ADEC Red Alarm			
41678	MDEC/ADEC Block Heater Control			
41679	Low Coolant Temperature Shutdown			
41680	MDEC/ADEC Load Shed Over Temperature			
41681	Maintenance Reminder	RW	WORD	
41682	Engine Derate Active (ECM only)	RW	WORD	
41683	Engine Stalled	RW	WORD	
41684	J1939 CAN Engine Shutdown	RW	WORD	Deere, Doosan, GM engines only
41685-41740	Reserved For Future Use	RW	WORD	
41741	Air-Fuel Module Start	RW	WORD	Waukesha only.
41742	No Dial Tone	RW	WORD	With optional dial-out feature only.
41743	Dialout Message Sent			
41744	No Modem at Powerup			
41745	Modem Connection Failed			
41746	Close Button Pressed	RW	WORD	
41747	Open Button Pressed			
41748	Key Switch Locked			
41749	Key Switch Unlocked			
41750	Auto Button Pressed			
41751	Off Button Pressed			
41752	Run Button Pressed			
41753	Gen Circuit Breaker Closed			
41754	Gen Circuit Breaker Opened			
41755	Util Circuit Breaker Closed			
41756	Util Circuit Breaker Opened			
41757	Common Warning			
41758	Common Load Shed			
41759	PGEN General Warning			
41760	PGEN General Fault			
41761	PGEN Comm Not Online			
41762	PGEN Duplicate ID			
41763	PGEN Missing Node			
41764	PGEN Extra Node			
41765	Auto Synch Disabled			
41766	Gen Volts and Hz Ok			
41767	Synch Frequency Match			
41768	Synch Phase Match			
41769	Synch Volts Match			
41770	Breaker Trip to Shutdown Time Delay Expired			
41771	Dead Bus Sense Fault			
41772	First On Fault			

*0x7FD6 = data unavailable. 0x7FFF = data is out of range.

Register	Data Description	Access	Data Type	Range/Units/Notes
41773	Fail to Synch Timeout	RW	WORD	
41774	Circuit Breaker Close Fault			
41775	Circuit Breaker Close Atts Fault			
41776	Circuit Breaker Open Fault			
41777	Circuit Breaker Current Fault			
41778	Circuit Breaker Common Fault			
41779	Contactors Output			
41780	Close Generator Circuit Breaker Output			
41781	Trip Generator Circuit Breaker Output			
41782	Remote Shutdown			
41783-41791	Reserved For Future Use	RW	WORD	
41792	Dual Start Application	RW	WORD	
41793	Starter A Failure			
41794	Starter B Failure			
41795	Dual Starter B			
41796	Controller Setup Warning			
41797	Phase Selection Error			
41798	Voltage Selection Error			
41799	Frequency Selection Error			
41800	kW Selection Error			
41801	EEPROM Block Initialized			
41802	Date Changed			
41803	Controller Initialized			
41804-41999	Reserved For Future Use			
42000-42512	Reserved For Factory Use			
42513-49998	Reserved For Future Use			
Device ID				
49999	Device ID	RO	WORD	Decision-Maker 6000 Device ID = 41
*0x7FD6 = data unavailable. 0x7FFF = data is out of range.				

7.4.3 Remapped Registers

Registers 40740–40837 have been mapped to 41550–41647 (defined common faults).

Register	Mapped to:	Description
40740	41550	Emergency Stop
40741	41551	Overspeed
40742	41552	Overcrank
40743	41553	High Coolant Temperature Shutdown
40744	41554	Oil Pressure Shutdown
40745	41555	Low Coolant Temperature Warn.
40746	41556	Low Fuel
40747	41557	High Coolant Temperature Warning
40748	41558	Oil Pressure Warning
40749	41559	Master Not In Auto
40750	41560	NFPA 110 Fault
40751	41561	Low Battery Voltage
40752	41562	High Battery Voltage
40753	41563	Battery Charger Fault
40754	41564	System Ready
40755	41565	Loss of ECM Comm
40756	41566	No Oil Pressure Signal
40757	41567	High Oil Temperature Shutdown
40758	41568	No Coolant Temperature Signal
40759	41569	Low Coolant Level
40760	41570	Speed Sensor Fault
40761	41571	Locked Rotor
40762	41572	Master Switch Error
40763	41573	Master Switch Open
40764	41574	Master Switch Off
40765	41575	AC Sensing Loss
40766	41576	Over Voltage
40767	41577	Under Voltage
40768	41578	Weak Battery
40769	41579	Over Frequency
40770	41580	Under Frequency
40771	41581	Load Shed kW Overload
40772	41582	Load Shed kW Under Frequency
40773	41583	Over Current Warning
40774	41584	EPS Supplying Load
40775	41585	Internal Fault
40776	41586	Engine Cooldown Delay
40777	41587	Engine Start Delay
40778	41588	Starting Aid
40779	41589	Generator Running
40780	41590	Air Damper Control
40781	41591	Ground Fault
40782	41592	EEPROM Write Failure
40783	41593	Critical Overvoltage
40784	41594	Alternator Protect Shutdown
40785	41595	Air Damper Indicator
40786	41596	Digital Input 01

Register	Mapped to:	Description
40787	41597	Digital Input 02
40788	41598	Digital Input 03
40789	41599	Digital Input 04
40790	41600	Digital Input 05
40791	41601	Digital Input 06
40792	41602	Digital Input 07
40793	41603	Digital Input 08
40794	41604	Digital Input 09
40795	41605	Digital Input 10
40796	41606	Digital Input 11
40797	41607	Digital Input 12
40798	41608	Digital Input 13
40799	41609	Digital Input 14
40800	41610	Digital Input 15
40801	41611	Digital Input 16
40802	41612	Digital Input 17
40803	41613	Digital Input 18
40804	41614	Digital Input 19
40805	41615	Digital Input 20
40806	41616	Digital Input 21
40807	41617	Analog Input 01
40808	41618	Analog Input 02
40809	41619	Analog Input 03
40810	41620	Analog Input 04
40811	41621	Analog Input 05
40812	41622	Analog Input 06
40813	41623	Analog Input 07
40814	41624	<i>Reserved for additional input</i>
40815	41625	
40816	41626	
40817	41627	
40818	41628	
40819	41629	
40820	41630	
40821	41631	
40822	41632	Defined Common Fault
40823	41633	Software Controlled RDO#1
40824	41634	Software Controlled RDO#2
40825	41635	Software Controlled RDO#3
40826	41636	Software Controlled RDO#4
40827	41637	<i>Reserved for factory use</i>
40828	41638	
40829	41639	
40830	41640	
40831	41641	
40832	41642	
40833	41643	
40834	41644	
40835	41645	
40836	41646	
40837	41647	

7.4.4 Relay Driver Outputs

Status. Registers 40838–40839 contain the status (active or not active) of the relay driver outputs (RDOs). Each register is a 16-bit word and each individual bit corresponds to one RDO. Figure 7-7 illustrates how the RDO status codes are stored.

The RDO is active if the corresponding bit is set (equal to 1). The example in Figure 7-6 shows that RDOs 7, 8, 12, 18, 23, and 30 are active.

To identify the functions assigned to the RDOs, check registers 40840–40870.

Setup. Registers 40840–40870 contain the RDO function and setpoint information. The function assigned to the RDO is indicated by the event codes shown in the first byte of the register. Event codes are listed in the table in Section 7.4.6. Setpoints are for analog inputs only; otherwise setpoint=0.

Register	RDO Number Corresponding to Each Bit															
40848	16	15	14	13	12	11	10	9	8	7	6	5	4	3	2	1
40849	—	31	30	29	28	27	26	25	24	23	22	21	20	19	18	17

Figure 7-5 RDO Status Registers

Register	RDO Status: 0 = Not Set (not active), 1 = Set (active)															
40848	0	0	0	0	1	0	0	0	1	1	0	0	0	0	0	0
40849	—	0	1	0	0	0	0	0	0	1	0	0	0	0	1	0

Figure 7-6 RDO Status Example

7.4.5 System Event Codes

Event codes are contained in registers 41500 through 41515. Each register is a 16-bit word, and each bit corresponds to a system event code. Figure 7-7 illustrates how the event codes are stored in the system event stack registers. The numbers 0–255 in Figure 7-7 correspond to the event codes shown in the System Event Codes table, Section 7.4.6. For example, number 6 corresponds to low fuel.

The condition indicated by the message code is active if the corresponding bit is set. Figure 7-8 shows register 41500 indicating low battery voltage, a high coolant temperature warning, and a low fuel condition.

Register	Event Code Indicated by Each Bit (See Section 7.4.6 for event code identification.)															
41500	15	14	13	12	11	10	9	8	7	6	5	4	3	2	1	0
41501	31	30	29	28	27	26	25	24	23	22	21	20	19	18	17	16
41502	47	46	45	44	43	42	41	40	39	38	37	36	35	34	33	32
41503	63	62	61	60	59	58	57	56	55	54	53	52	51	50	49	48
41504	79	78	77	76	75	74	73	72	71	70	69	68	67	66	65	64
41505	95	94	93	92	91	90	89	88	87	86	85	84	83	82	81	80
41506	111	110	109	108	107	106	105	104	103	102	101	100	99	98	97	96
41507	127	126	125	124	123	122	121	120	119	118	117	116	115	114	113	112
41508	143	142	141	140	139	138	137	136	135	134	133	132	131	130	129	128
41509	159	158	157	156	155	154	153	152	151	150	149	148	147	146	145	144
41510	175	174	173	172	171	170	169	168	167	166	165	164	163	162	161	160
41511	191	190	189	188	187	186	185	184	183	182	181	180	179	178	177	176
41512	207	206	205	204	203	202	201	200	199	198	197	196	195	194	193	192
41513	223	222	221	220	219	218	217	216	215	214	213	212	211	210	209	208
41514	239	238	237	236	235	234	233	232	231	230	229	228	227	226	225	224
41515	255	254	253	252	251	250	249	248	247	246	245	244	243	242	241	240

Figure 7-7 Event Codes Stored in System Event Stack Registers 41500 through 41515

Register	Event Code Status: 0 = Not Set, 1 = Set															
41500	0	0	0	0	1	0	0	0	1	1	0	0	0	0	0	0

Figure 7-8 Event Code Status Example, Register 41500

7.4.6 System Event Code Table

The system event codes in the following table are used for relay driver output functions as well as for events in the event history and the event stack.

Code	Description
0	Emergency Stop
1	Overspeed
2	Overcrank
3	High Coolant Temperature Shutdown
4	Oil Pressure Shutdown
5	Low Coolant Temperature
6	Low Fuel Warning
7	High Coolant Temperature Warning
8	Oil Pressure Warning
9	Master Not In Auto
10	NFPA 110 Fault
11	Low Battery Voltage
12	High Battery Voltage
13	Battery Charger Fault
14	System Ready
15	Loss of ECM Comm
16	No Oil Pressure Signal
17	High Oil Temperature Shutdown
18	No Coolant Temperature Signal
19	Low Coolant Level
20	Speed Sensor Fault
21	Locked Rotor
22	Master Switch Error
23	Master Switch Open
24	Master Switch Off
25	AC Sensing Loss
26	Over Voltage
27	Under Voltage
28	Weak Battery
29	Over Frequency
30	Under Frequency
31	Load Shed kW Overload
32	Load Shed kW Under Frequency
33	Over Current
34	EPS Supplying Load
35	Internal Fault
36	Engine Cooldown Delay
37	Engine Start Delay
38	Starting Aid
39	Generator Running
40	Air Damper Control
41	Ground Fault
42	EEPROM Write Failure
43	Critical Overvoltage
44	Alternator Protect Shutdown
45	Air Damper Indicator
46	Digital Input 01

Code	Description
47	Digital Input 02
48	Digital Input 03
49	Digital Input 04
50	Digital Input 05
51	Digital Input 06
52	Digital Input 07
53	Digital Input 08
54	Digital Input 09
55	Digital Input 10
56	Digital Input 11
57	Digital Input 12
58	Digital Input 13
59	Digital Input 14
60	Digital Input 15
61	Digital Input 16
62	Digital Input 17
63	Digital Input 18
64	Digital Input 19
65	Digital Input 20
66	Digital Input 21
67	Analog Input 01
68	Analog Input 02
69	Analog Input 03
70	Analog Input 04
71	Analog Input 05
72	Analog Input 06
73	Analog Input 07
74	<i>Reserved for additional input</i>
75	<i>Reserved for additional input</i>
76	<i>Reserved for additional input</i>
77	<i>Reserved for additional input</i>
78	<i>Reserved for additional input</i>
79	<i>Reserved for additional input</i>
80	<i>Reserved for additional input</i>
81	<i>Reserved for additional input</i>
82	Defined Common Fault
83	Software Controlled RDO#1
84	Software Controlled RDO#2
85	Software Controlled RDO#3
86	Software Controlled RDO#4
99	Genset Parameter Warning
100	Genset S/N Mismatch Warning
101	Genset S/N Mismatch Shutdown
103	Protective Relay Overvoltage
104	Protective Relay Under Voltage
105	Protective Relay Overfrequency
106	Protective Relay Underfrequency
107	Protective Relay Reverse Power
108	Protective Relay Over Power
109	Protective Relay Loss of Field
110	Protective Relay Overcurrent Vr
111	Reverse Power Shutdown

Code	Description
112	Over Power Shutdown
113	Loss of Field Shutdown
114	Over Current Shutdown
115	Common Protective Relay Output
116	In Synch
117	Breaker Trip
118	Fuel Valve Relay
119	Pre Lube Relay
120	Air -Fuel Module Start
121	Oil Temperature Loss of Signal
122	High Oil Temperature Warning
123	Intake Air Temperature Loss of Signal
124	High Intake Air Temperature Warning
125	High Intake Air Temperature Shutdown
126	MDEC/ADEC Yellow Alarm
127	MDEC/ADEC Red Alarm
128	MDEC/ADEC Block Heater Control
129	Low Coolant Temperature Shutdown
130	MDEC/ADEC Load Shed Over Temperature
131	<i>Reserved For Future Use</i>
132	Engine Derate Active
133	Engine Stalled
134	J1939 CAN Engine Shutdown
135-174	Reserved for Future Use
175	No Oil Press1 Signal
176	No Oil Press2 Signal
177	No Cool Temp1 Signal
178	No Cool Temp2 Signal
179	Hi Cool Temp1 Shtdwn
180	Hi Cool Temp2 Shtdwn
181	Oil Press1 Shutdown
182	Oil Press2 Shutdown
183	Hi Cool Temp1 Warn
184	Hi Cool Temp2 Warn
185	Lo Cool Temp1 Warn
186	Lo Cool Temp2 Warn
187	Oil Press1 Warning
188	Oil Press2 Warning
189	Coolant Pressr Warn
190	No Cool Press Signal
191	Air -Fuel Module Start
192	No Dial Tone
193	Dialout Message Sent
194	No Modem at Powerup
195	Modem Connection Failed
196	Close Button Acknowledged
197	Open Button Acknowledged
198	Key Switch Locked
199	Key Switch Unlocked

Code	Description
200	Auto Button Acknowledged
201	Off Button Acknowledged
202	Run Button Acknowledged
203	Generator Circuit Breaker Closed
204	Generator Circuit Breaker Open
205	Utility circuit Breaker Closed
206	Utility Circuit Breaker Open
207	Common Warning
208	Common Load Shed
209	PGEN Common Warning
210	PGEN Common Fault
211	PGEN Comm Not Online
212	PGEN Duplicate ID
213	PGEN Missing Node
214	PGEN Extra Node
215	Auto Synch Disabled
216	Volts and Freq OK
217	Synch Frequency matched
218	Synch Phase matched
219	Synch Volts Matched
220	CB Trip to Shutdown Timeout
221	Dead Bus Sense Error
222	First On Fault
223	Fail to Synch Timeout
224	CB Close Fault
225	CB Close Attempts Fault
226	CB Open Fault
227	CB Current Fault
228	CB Common Fault
229	Contactors Output
230	Close Generator Circuit Breaker
231	External Breaker Trip
232	Remote Shutdown
233-241	Reserved for Future Use
242	Dual Starter App
243	Starter A Failure
244	Starter B Failure
245	Dual Starter B
246	Controller Setup Error
247	Phase Selection Error
248	Voltage Selection Error
249	Frequency Selection Error
250	kW Selection Error
251	EEPROM Block Initialized
252	Date Changed
253	Controller Initialized

7.4.7 Digital Auxiliary Input Functions

The following function ID codes are used in registers 40227-40499 to identify the function that is assigned to each digital input. The functions are assigned through the controller keypad or using Monitor III or SiteTech software.

Function ID	Name	Notes
1	Warning	
2	Shutdown Type A	
3	Shutdown Type B	
4	Voltage Raise	
5	Voltage Lower	
6	VAR PF Mode	
7	Remote Shutdown	
8	Remote Reset	
9	Air Damper	
10	Low Fuel Warning	
11	Field Over Volts	
12	Idle Mode	ECM only
13	Battle Switch	
14	Ground Fault	
15	Bat Chgr Fault	
16	High Oil Temperature	
17	Low Coolant Lvl	
18	Low Coolant Temperature	ECM only (not user-assignable)
19	Breaker Closed	(not user-assignable)
20	Enable Synch	
21	AFM Shutdown	Waukesha only (not user-assignable)
22	Knock Shutdown	
23	Deton Warning	
24	Deton Shutdown	
25	Low Fuel Shutdown	(not user-assignable)
26	Utility CB Aux Contacts	
27	Auxiliary Open Command	
28	Auxiliary Close Command	
29	Speed Raise	
30	Speed Lower	
31	Auto Synch	
32	Synch Permissive	
33	Synch Test/Check	
34	Synch Reset	
35	First Enable	

Function ID	Name	Notes
36	First On Reset	
37	Load Enable	
38	kW Baseload Mode	
39	Load Ramp Hold	
40	Frequency Trim Enable	
41	Voltage Trim Enable	
42	System kW Control Enable	
43	System kVAR/PF Control Enable	
44	External kW Setpoint Enable	
45	External kVAR/PF Setpoint Enable	
46	kVAR Control Enable	
47	PF Control Enable	
48	Reactive Droop Enable	
49	Circuit Breaker Fault Reset	
50	Gen CB over Current Trip	
51	VSG Disable	

Section 8 M340 and M340+ ATS Controllers

8.1 Introduction

The M340 and M340+ ATS controllers use KBUS protocol for communication. Modbus®/KBUS converter kits are required for Modbus communication with these controllers. See Figure 8-2.

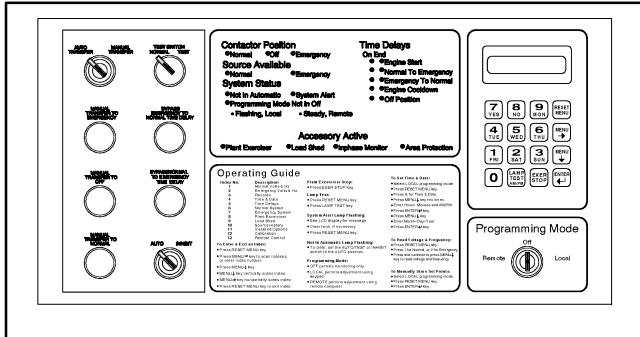

Figure 8-1 M340+ Controller

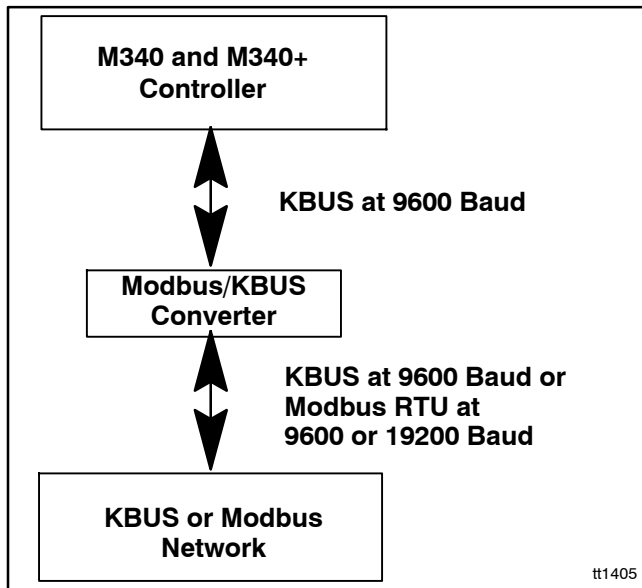
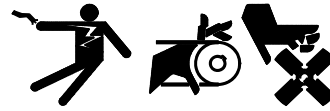

Figure 8-2 Modbus/KBUS Converter Function

Installing the Modbus/KBUS converter kit allows this controller to communicate with a personal computer running Monitor III software. For Modbus applications other than Monitor III, the Modbus master must be programmed to read the Modbus registers shown in this manual. A system designer trained in the application of Modbus protocol must write and thoroughly test the program before implementation.

8.2 Hardware and Connections

⚠ WARNING



**Accidental starting.
Can cause severe injury or death.**

Disconnect the battery cables before working on the generator set. Remove the negative (-) lead first when disconnecting the battery. Reconnect the negative (-) lead last when reconnecting the battery.

Disabling the generator set. Accidental starting can cause severe injury or death. Before working on the generator set or connected equipment, disable the generator set as follows: (1) Move the generator set master switch to the OFF position. (2) Disconnect the generator power to the battery charger. (3) Remove the battery cables, negative (-) lead first. Reconnect the negative (-) lead last when reconnecting the battery. Follow these precautions to prevent starting of the generator set by an automatic transfer switch, remote start/stop switch, or engine start command from a remote computer.

Modbus/KBUS converter kit GM41143-KP3 replaces RS-232 and RS-485 communication modules and allows the selection of either KBUS or Modbus communication. See Figure 8-3 and Figure 8-4 for the converter location inside the controller.

If your device is equipped with an RS-232/RS-485 communication module, remove the old communication module and ribbon cable before installing the new Modbus/KBUS converter and ribbon cable.

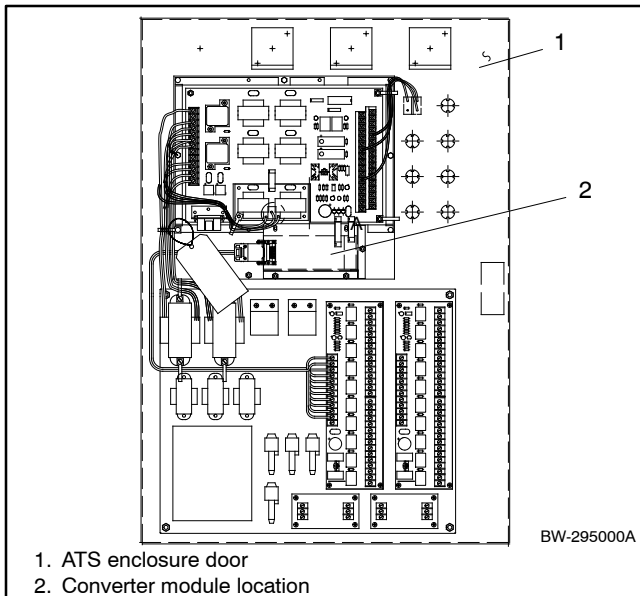

Figure 8-3 Modbus/KBUS Converter Location

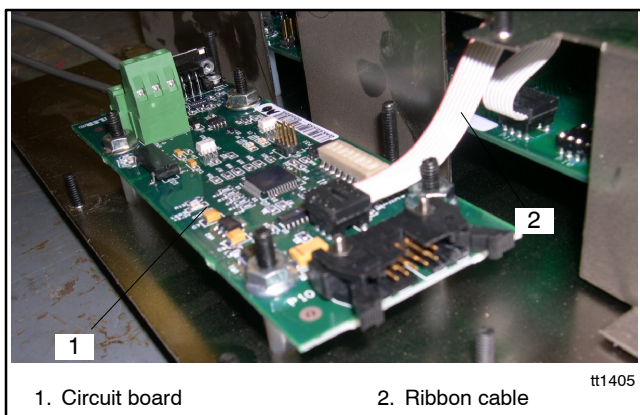

Figure 8-4 Modbus/KBUS Converter Kit, Installed

Figure 8-5 shows the Modbus/KBUS converter circuit board connections and DIP switches. Refer to Installation Instructions TT-1405, provided with converter kit, for converter installation and connection instructions. Set converter DIP switches for baud rate, device type, and network address as described in TT-1405.

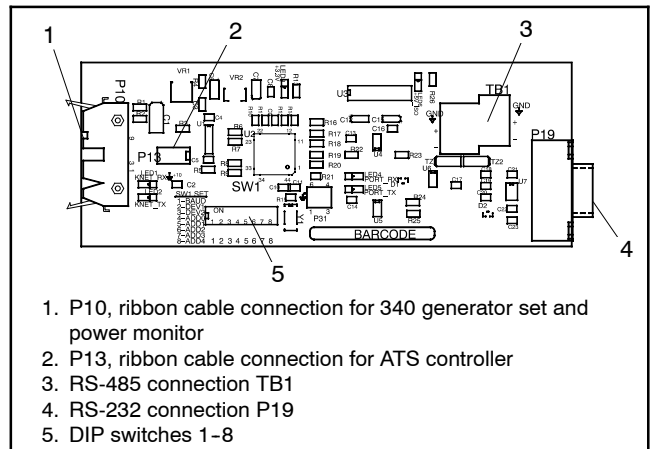

Figure 8-5 Modbus/KBUS Converter Board

8.3 Controller Setup

Configure the controller for remote communications by setting the parameters shown in Figure 8-6. See TT-1405 and the controller Operation Manual for more information.

Device	Menu or Index	Parameter	Setting
M340 or M340+ATS Controller	Index 13, Remote Control and Monitoring Settings	Remote Control, On-Line?	YES
		Local, LAN, Remote, or Remote Area Network	Select the appropriate setting for your connection type. Use Local for Ethernet connections. See TT-1405 for more information.
		Address	Any *
		Baud rate	9600 †
<p>* The network address for Series 340 devices is set using DIP switches on the converter module and will override the network address on the controller.</p> <p>† This baud rate must be set at 9600 to match the KBUS side of the Modbus/KBUS converter. It may be different from the Modbus baud rates of other devices in the system.</p>			

Figure 8-6 Controller Settings for Modbus Communication

8.4 Modbus Registers

Refer to Section 1.3 for definitions of terms and symbols used in the register tables.

Register	Data Description	Access	Data Type	Range/Units
40001				
40002	System Time	RO	WORD	
40003	Day of Week	RO	WORD	
40004	Month	RO	WORD	1-12
40005	Day	RO	WORD	1-31
40006	Year	RO	WORD	
40007	Week of Month	RO	WORD	
40008	Time Not In Normal Since Reset	RO	WORD	hrs
40009	Time In Emergency Since Reset			hrs
40010	Days of Operation Since Reset			days
40011	Transfers Since Reset			
40012	Month of Reset			1-12
40013	Day of Reset			1-31
40014	Year of Reset			
40015	Time Not In Normal	RO	WORD	hrs
40016	Time In Emergency	RO	WORD	hrs
40017	Days of Operation	RO	WORD	days
40018	Transfers	RO	WORD	
40019	Month in Operation	RO	WORD	1-12
40020	Day in Operation	RO	WORD	1-31
40021	Year in Operation	RO	WORD	
40022	Voltage A-B Normal	RO	WORD	volts
40023	Voltage B-C Normal	RO	WORD	volts
40024	Voltage C-A Normal	RO	WORD	volts
40025	Freq. A-C Normal	RO	WORD	Hz
40026	Voltage A-B Emerg.	RO	WORD	volts
40027	Voltage B-C Emerg.	RO	WORD	volts
40028	Voltage C-A Emerg.	RO	WORD	volts
40029	Freq. A-C Emerg.	RO	WORD	Hz
40030	Exerciser Time Remaining	RO	WORD	
40031	Month of Last Exercise	RO	WORD	1-12
40032	Day of Last Exercise	RO	WORD	1-31
40033	Year of Last Exercise	RO	WORD	
40034	Time of Last Outage	RO	WORD	
40035	Month of Last Outage	RO	WORD	1-12
40036	Day of Last Outage	RO	WORD	1-31
40037	Year of Last Outage	RO	WORD	
40038	Duration of Last Outage	RO	WORD	
40039	History Event #1 Code	RO	WORD	code
40040	History Event #2 Code	RO	WORD	code
40041	History Event #2 Month	RO	WORD	1-12
40042	History Event #2 Day	RO	WORD	1-31
40043	History Event #2 Year	RO	WORD	
40044	History Event #3 Code	RO	WORD	code
40045	History Event #3 Month	RO	WORD	1-12
40046	History Event #3 Day	RO	WORD	1-31

Register	Data Description	Access	Data Type	Range/Units
40047	History Event #3 Year	RO	WORD	
40048	History Event #4 Code	RO	WORD	code
40049	History Event #4 Month	RO	WORD	1-12
40050	History Event #4 Day	RO	WORD	1-31
40051	History Event #4 Year	RO	WORD	
40052	Alert Code	RO	WORD	Alert Code
40064	Status	RO	WORD[0-7]	0-1: Sw. Position (00=undefined; 01=Normal; 10=Emerg.; 11=undefined) 2: Normal Source Available 3: Emerg. Source Available 4-5: Prog. Mode Sw. (00=Off; 01=Remote; 10=Local; 11= undefined) 6: Test Sw. In Auto 7: Manual Transfer Mode
40066	Settings	RO	WORD[0-7]	0: Plant Exerciser Enabled 1: Load Shed Enabled 2: In Phase Monitor Enabled 3: Area Protection Enabled 4: Normal Phase Sequence (0=ABC; 1=BAC) 5: Emerg. Phase Sequence (0=ABC; 1=BAC) 6: Normal Number of Phases (0=Single; 1=Three) 7: Emerg. Number of Phases (0=Single; 1=Three)
400677	Settings	RO	WORD[4-6]	4: Extended Time Delays Enabled 5: Manual Override Enabled 6: Load Transfer Enabled
40078	Off to Emergency Time Delay	RO	WORD	0-5940 seconds; 0x7FFF if NOT M340+
40079	Off to Normal Time Delay	RO	WORD	0-5940 seconds; 0x7FFF if NOT M340+
40080	Engine Start Time Delay	RO	WORD	
40081	Normal to Emerg. Time Delay	RO	WORD	
40082	Emerg. To Normal Time Delay	RO	WORD	
40083	Engine Cooldown Time Delay	RO	WORD	
40084	Before Emerg. Time Delay	RO	WORD	
40085	After Emerg. Time Delay	RO	WORD	
40086	Sequence to Emerg. Time Delay	RO	WORD	
40087	Return to Emerg. Loads	RO	WORD	(1-9)
40088	Before Normal Time Delay	RO	WORD	
40089	After Normal Time Delay	RO	WORD	
40090	Sequence to Normal Time Delay	RO	WORD	
40091	Return to Normal Loads	RO	WORD	(1-9)
40092	Over Voltage Dropout Normal	RO	WORD	
40093	Over Voltage Pickup Normal	RO	WORD	
40094	Under Voltage Pickup Normal	RO	WORD	
40095	Under Voltage Dropout Normal	RO	WORD	
40096	Over Frequency Dropout Normal	RO	WORD	
40097	Over Frequency Pickup Normal	RO	WORD	
40098	Under Frequency Pickup Normal	RO	WORD	
40099	Under Frequency Dropout Normal	RO	WORD	
40100	Over Voltage Dropout Emerg.	RO	WORD	
40101	Over Voltage Pickup Emerg.	RO	WORD	

Register	Data Description	Access	Data Type	Range/Units
40102	Under Voltage Pickup Emerg.	RO	WORD	
40103	Under Voltage Dropout Emerg.	RO	WORD	
40104	Over Frequency Dropout Emerg.	RO	WORD	
40105	Over Frequency Pickup Emerg.	RO	WORD	
40106	Under Frequency Pickup Emerg.	RO	WORD	
40107	Under Frequency Dropout Emerg.	RO	WORD	
40108	System Voltage Normal	RO	WORD	
40109	System Frequency Normal	RO	WORD	
40110	System Voltage Emerg.	RO	WORD	
40111	System Frequency Emerg.	RO	WORD	
40120-40124	Designation	RO	WORD*5	9 chars, 1 per byte, first char = LSB, last byte ignored
40125-40134	Load Description	RO	WORD*10	20 chars, 1 per byte, first char = LSB
40135-40144	Location	RO	WORD*10	20 chars, 1 per byte, first char = LSB
40145-40153	Branch	RO	WORD*9	18 chars, 1 per byte, first char = LSB
40154-40171	Options	RO	WORD*18	36 chars, 1 per byte, first char = LSB
40172-40174	Serial No.	RO	WORD*3	6 chars, 1 per byte, first char = LSB
40175-40177	Controller Serial No.	RO	WORD*3	6 chars, 1 per byte, first char = LSB
40178-40179	Switch Size in Amps	RO	WORD*2	4 chars, 1 per byte, first char = LSB
40180	Number of Poles	RO	WORD	1 char, first char = LSB
40194	Calendar Start Time #1	RO	WORD	
40195	Calendar Run Time #1	RO	WORD	
40196	Calendar Start Time #2	RO	WORD	
40197	Calendar Run Time #2	RO	WORD	
40198	Calendar Start Time #3	RO	WORD	
40199	Calendar Run Time #3	RO	WORD	
40200	Calendar Start Time #4	RO	WORD	
40201	Calendar Run Time #4	RO	WORD	
40202	Calendar Start Time #5	RO	WORD	
40203	Calendar Run Time #5	RO	WORD	
40204	Day of Week #1 (Calendar)	RO	WORD	
40205	First Week of Month #1 (Calendar)	RO	WORD	
40206	Second Week of Month #1 (Calendar)	RO	WORD	
40207	Day of Week #2 (Calendar)	RO	WORD	
40208	First Week of Month #2 (Calendar)	RO	WORD	
40209	Second Week of Month #2 (Calendar)	RO	WORD	
40210	Day of Week #3 (Calendar)	RO	WORD	
40211	First Week of Month #3 (Calendar)	RO	WORD	
40212	Second Week of Month #3 (Calendar)	RO	WORD	
40213	Day of Week #4 (Calendar)	RO	WORD	
40214	First Week of Month #4 (Calendar)	RO	WORD	
40215	Second Week of Month #4 (Calendar)	RO	WORD	
40216	Day of Week #5 (Calendar)	RO	WORD	
40217	First Week of Month #5 (Calendar)	RO	WORD	
40218	Second Week of Month #5 (Calendar)	RO	WORD	

Register	Data Description	Access	Data Type	Range/Units
40219	Day of Week #1 (14-day)	RO	WORD	
40220	Second Day of Week #1 (14-day)	RO	WORD	
40221	Week #1 (14-day)	RO	WORD	
40222	Day of Week #2 (14-day)	RO	WORD	
40223	Second Day of Week #2 (14-day)	RO	WORD	
40224	Week #2 (14-day)	RO	WORD	
40225	Day of Week #3 (14-day)	RO	WORD	
40226	Second Day of Week #3 (14-day)	RO	WORD	
40227	Week #3 (14-day)	RO	WORD	
40228	Day of Week #4 (14-day)	RO	WORD	
40229	Second Day of Week #4 (14-day)	RO	WORD	
40230	Week #4 (14-day)	RO	WORD	
40231	Day of Week #5 (14-day)	RO	WORD	
40232	Second Day of Week #5 (14-day)	RO	WORD	
40233	Week #5 (14-day)	RO	WORD	
40234	First Day of Week #1 (7-day)	RO	WORD	
40235	Second Day of Week #1 (7-day)	RO	WORD	
40236	First Day of Week #2 (7-day)	RO	WORD	
40237	Second Day of Week #2 (7-day)	RO	WORD	
40238	First Day of Week #3 (7-day)	RO	WORD	
40239	Second Day of Week #3 (7-day)	RO	WORD	
40240	First Day of Week #4 (7-day)	RO	WORD	
40241	Second Day of Week #4 (7-day)	RO	WORD	
40242	First Day of Week #5 (7-day)	RO	WORD	
40243	Second Day of Week #5 (7-day)	RO	WORD	
40300	Timed Run Time	RW	WORD	minutes

8.5 M340/M340+ Alert Codes

Alert Code	Description
1	N Overvoltage AB
2	N Overvoltage BC
3	N Overvoltage CA
4	N Undervoltage AB
5	N Undervoltage BC
6	N Undervoltage CA
7	N Overfrequency
8	N Underfrequency
9	N Phase Loss
10	E Overvoltage AB
11	E Overvoltage BC
12	E Overvoltage CA
13	E Undervoltage AB
14	E Undervoltage BC
15	E Undervoltage CA
16	E Overfrequency
17	E Underfrequency
18	E Phase Loss

Alert Code	Description
19	N Overvoltage 1-phase
20	N Undervoltage 1-phase
21	N Overfrequency 1-phase
22	N Underfrequency 1-phase
23	E Overvoltage1-phase
24	E Undervoltage1-phase
25	E Overfrequency 1-phase
26	E Underfrequency 1-phase
27	Aux. Sw. Fault
28	Double Aux. Sw. Fault
29	Transfer Hang
30	Power Down Error
31	RAM Error
32	Memory Error
33	Manual Transfer
34	Remote Fault #1
35	Remote Fault #2

Section 9 MPAC 1000 ATS Controller

9.1 Specifications

The MPAC™ 1000 controller's Modbus® communication capability:

- Supports industry-standard Modbus® RTU protocol.
- Can use Modbus® TCP protocol with the addition of a Modbus/Ethernet converter.
- Connects to a Modbus® master singly over an RS-232 line.
- Uses RS-485 connections to connect to a Modbus® master singly or over an RS-485 network.
- Connects to an Ethernet network using a Modbus/Ethernet converter.
- Uses standard baud rates of 9600 or 19200.

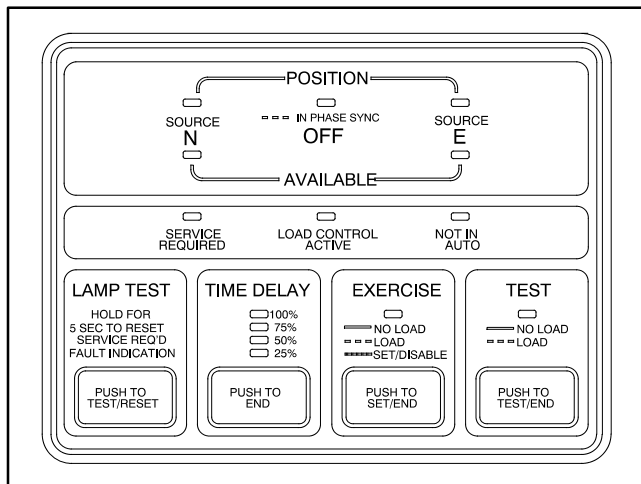
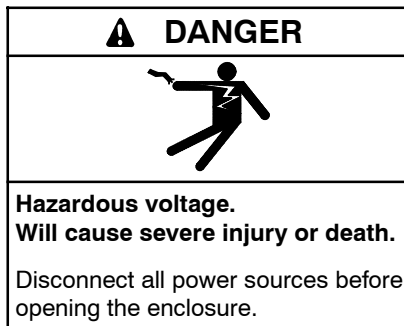

Figure 9-1 MPAC™ 1000 Controller

9.2 Hardware Connections



Servicing the transfer switch. Hazardous voltage can cause severe injury or death. Deenergize all power sources before servicing. Turn off the main circuit breakers of all transfer switch power sources and disable all generator sets as follows: (1) Move all generator set master controller switches to the OFF position. (2) Disconnect power to all battery chargers. (3) Disconnect all battery cables, negative (-) leads first. Reconnect negative (-) leads last when

reconnecting the battery cables after servicing. Follow these precautions to prevent the starting of generator sets by an automatic transfer switch, remote start/stop switch, or engine start command from a remote computer. Before servicing any components inside the enclosure: (1) Remove all jewelry. (2) Stand on a dry, approved electrically insulated mat. (3) Test circuits with a voltmeter to verify that they are deenergized.

NOTICE

Electrostatic discharge damage. Electrostatic discharge (ESD) damages electronic circuit boards. Prevent electrostatic discharge damage by wearing an approved grounding wrist strap when handling electronic circuit boards or integrated circuits. An approved grounding wrist strap provides a high resistance (about 1 megohm), *not a direct short*, to ground.

Note: Install communication conductors in raceways, cables, or conduit separate from AC power conductors.

The controller uses a non-isolated RS-485 port with connection speeds of 9.6 kbps and 19.2 kbps.

Connection Procedure

1. Disconnect power to the transfer switch by opening switches or circuit breakers before opening the enclosure.
2. Open the controller housing and locate terminal strip TB1. See Figure 9-2.

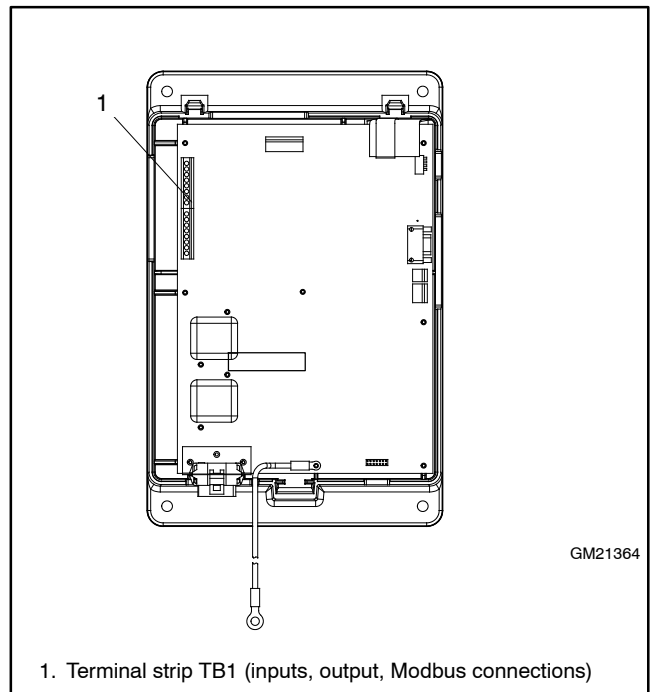

Figure 9-2 ATS Controller, Cover Removed

3. Connect the Modbus® input and output to the terminals shown in Figure 9-3. Use #12-24 AWG twisted-pair shielded cable; Belden cable #9841 or equivalent is recommended. Connect A to negative (-), B to positive (+), and the shield to ground as shown in Figure 9-3.
4. Tighten the connections to 0.5 Nm (4.4 in. lb.).
5. Replace the controller housing cover.
6. Close and lock the transfer switch enclosure door before reconnecting the power.

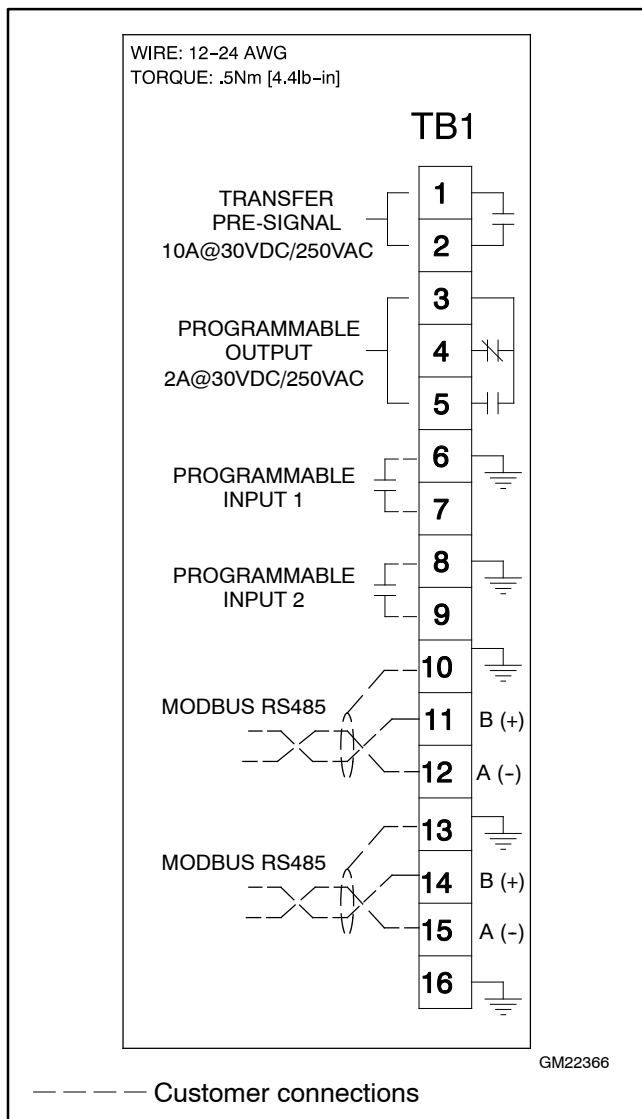

Figure 9-3 Terminal Strip TB1 Connections

9.3 Controller Setup

Use a personal computer (PC) running the ATS Controller Setup Program to set the address and baud rate of the Modbus® network interface port. Refer to the Setup Program Operation Manual for instructions for using the program, including creating data windows.

Follow the instructions in the Setup Program Operation Manual to use the Network Interface Port data window to check and set the address and baud rate of the Modbus® network interface port to match the other devices in the network. See Figure 9-4.

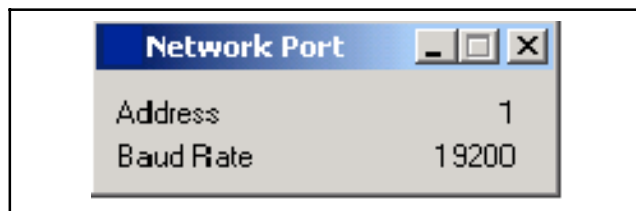

Figure 9-4 Network Interface Port Display Window

The Network Interface Port display window shows the address and baud rate of the Modbus® network interface port.

Use the Network Interface Port setup window to set the Modbus® network interface port to communicate with the other devices in the network. See Figure 9-5.

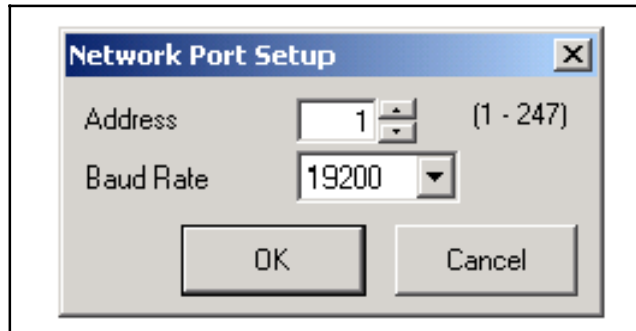

Figure 9-5 Network Interface Port Setup Window

Choose a unique network address for each device in the network. Type in the address or use the up and down arrows. Choose the baud rate from the drop-down list. Allowable baud rates are 9600 and 19200 baud. Select the baud rate to match the other devices on the network.

9.4 Modbus Registers

Refer to Section 1.3 for definitions of terms and symbols used in the register tables.

Time delays, setpoints, inputs and outputs, and other user-defined parameters are programmed using the Setup Program. Refer to the Setup Program Operation Manual for instructions. See the List of Related Materials for document part numbers.

9.4.1 Guide to the Register Map

Description	Registers
Monitoring	40001-40021
Setup	40022-40030
Time delays	400032-40044
Trip point settings	40045-40064
Outputs (event code)	40066-40089
Inputs (event code)	40090-40099
Event history	40150-40550
I/O status	40600-40605
Active time delay	40650-40652
Accessories	40740-40742
DIP switch positions	40743
Pre/post transfer delays	40750-40785
Common alarms	40800-40864
Exerciser	40900-40994
Last outage	41010-41013
Customer-defined descriptions *	41110-41149
Code versions	41200-41205
Time/date	41250-41254
Maintenance history	41300-41351
Disable manual exercise	41352
Device ID	49999

* Descriptions entered through Setup or Monitor III software.

9.4.2 Modbus Registers

Register	Data Description	Access	Data Type	Range/Units
40001	System Overview	RO	WORD [0:14]	0-1: Contactor Position (00 = Off; 01 = Normal; 10 = Emerg; 11 = Fault) 2: Preferred Source (0 = Source1; 1 = Source2) 3-12: Top Event on Warning Stack 13: Preferred Source Available (0 = No, 1 = Yes) 14: Standby Source Available (0 = No, 1 = Yes)
40002	SourceA Line-Neutral L1-L0	RO	WORD	Volts AC * 10
40003	SourceA Line-Neutral L2-L0	RO	WORD	Volts AC * 10
40004	SourceA Line-Neutral L3-L0	RO	WORD	Volts AC * 10
40005	SourceB Line-Neutral L1-L0	RO	WORD	Volts AC * 10
40006	SourceB Line-Neutral L2-L0	RO	WORD	Volts AC * 10
40007	SourceB Line-Neutral L3-L0	RO	WORD	Volts AC * 10
40008	SourceA Line Voltage L1-L2	RO	WORD	Volts AC * 10
40009	SourceA Line Voltage L2-L3	RO	WORD	Volts AC * 10
40010	SourceA Line Voltage L3-L1	RO	WORD	Volts AC * 10
40011	SourceB Line Voltage L1-L2	RO	WORD	Volts AC * 10
40012	SourceB Line Voltage L2-L3	RO	WORD	Volts AC * 10
40013	SourceB Line Voltage L3-L1	RO	WORD	Volts AC * 10

Register	Data Description	Access	Data Type	Range/Units
40014	SourceA Frequency	RO	WORD	Hz * 10
40015	SourceB Frequency	RO	WORD	Hz * 10
40016	<i>Reserved for future use</i>			Return 0
40017	<i>Reserved for future use</i>			Return 0
40018	<i>Reserved for future use</i>			Return 0
40019	<i>Reserved for future use</i>			Return 0
40020	<i>Reserved for future use</i>			Return 0
40021	<i>Reserved for future use</i>			Return 0
40022	Source Phase Sequence Actual	RO	WORD[0:3]	0-1: SourceA 01 = ABC; 00 = CBA; 10 = N/A; 11 = ERR 2-3: SourceB 01 = ABC; 00 = CBA; 10 = N/A; 11 = ERR
40023	Source Phase Sequence Expected	RW	WORD[0]	0: 1 = ABC; 0 = CBA
40024	SourceA Nominal Voltage	RW	WORD	Volts AC * 10
40025	SourceB Nominal Voltage	RW	WORD	Volts AC * 10
40026	SourceA Nominal Frequency	RW	WORD	Hz * 10
40027	SourceB Nominal Frequency	RW	WORD	Hz * 10
40028	SourceA Number of Phases	RW	WORD	1 or 3
40029	SourceB Number of Phases	RW	WORD	1 or 3
40030	Rated Amperage	RW	WORD	0-4000
40032	SourceA Engine Start Time Delay (ID 0x0001)	RW	WORD	0-6 sec
40033	SourceB Engine Start Time Delay (ID 0x0002)	RW	WORD	0-6 sec
40034	SourceA Ext Engine Start Time Delay (ID 0x0003)	RW	WORD	0-5999 sec
40035	SourceB Ext Engine Start Time Delay (ID 0x0004)	RW	WORD	0-5999 sec
40036	SourceA Engine Cooldown Time Delay (ID 0x0005)	RW	WORD	0-5999 sec
40037	SourceB Engine Cooldown Time Delay (ID 0x0006)	RW	WORD	0-5999 sec
40038	Preferred to Standby Time Delay (ID 0x0007)	RW	WORD	0-5999 sec
40039	Standby to Preferred Time Delay (ID 0x0008)	RW	WORD	0-5999 sec
40040	Off to Preferred Time Delay (ID 0x0009)	RW	WORD	0-5999.9 sec * 10
40041	Off to Standby Time Delay (ID 0x000A)	RW	WORD	0-5999.9 sec * 10
40042	Acquire Standby Source (ID 0x000B)	RW	WORD	1-5999 sec
40043	InPhase Monitor Synch (ID 0x000C)	RW	WORD	1-5999 sec
40044	<i>Reserved for future use</i>			Return 0
40045	SourceA Over Volt Dropout Trip Point	RW	WORD	(105 - 135) % of rated source voltage
40046	SourceA Over Volt Pickup Trip Point	RW	WORD	(95 - 100)% of over voltage dropout point
40047	SourceA Under Volt Pickup Trip Point	RW	WORD	(85 - 100) % of rated source voltage
40048	SourceA Under Volt Dropout Trip Point	RW	WORD	(75 - 98) % of overvoltage pickup point
40049	SourceA Voltage Debounce Time	RW	WORD	Sec * 10 (0.1-9.9)
40050	SourceB Over Volt Dropout Trip Point	RW	WORD	(105 - 135) % of rated source voltage
40051	SourceB Over Volt Pickup Trip Point	RW	WORD	(95 - 100)% of over voltage dropout point
40052	SourceB Under Volt Pickup Trip Point	RW	WORD	(85 - 100) % of rated source voltage
40053	SourceB Under Volt Dropout Trip Point	RW	WORD	(75 - 98) % of overvoltage pickup point
40054	SourceB Voltage Debounce Time	RW	WORD	Sec * 10 (0.1-9.9)
40055	SourceA Over Freq Dropout Trip Point	RW	WORD	(101 - 105) % of overfreq pickup point

Register	Data Description	Access	Data Type	Range/Units
40056	SourceA Over Freq Pickup Trip Point	RW	WORD	(105 - 120) % of rated source freq
40057	SourceA Under Freq Dropout Trip Point	RW	WORD	(95 - 99) % of underfreq pickup point
40058	SourceA Under Freq Pickup Trip Point	RW	WORD	(80 - 95)% of rated system frequency
40059	SourceA Freq Dropout Time	RW	WORD	Sec * 10 (0.1-15.0)
40060	SourceB Over Freq Dropout Trip Point	RW	WORD	(101 -105) % of overfreq pickup point
40061	SourceB Over Freq Pickup Trip Point	RW	WORD	(105 - 120) % of rated source freq
40062	SourceB Under Freq Dropout Trip Point	RW	WORD	(95 - 99) % of underfreq pickup point
40063	SourceB Under Freq Pickup Trip Point	RW	WORD	(80 - 95)% of rated system frequency
40064	SourceB Freq Dropout Time	RW	WORD	Sec * 10 (0.1-15.0)
40065	ATS Controller Output	RW	WORD	Event Code (see Section 9.4.3)
40066	I/O Module 1 Output 1	RW	WORD	Event Code (see Section 9.4.3)
40067	I/O Module 1 Output 2	RW	WORD	Event Code (see Section 9.4.3)
40068	I/O Module 1 Output 3	RW	WORD	Event Code (see Section 9.4.3)
40069	I/O Module 1 Output 4	RW	WORD	Event Code (see Section 9.4.3)
40070	I/O Module 1 Output 5	RW	WORD	Event Code (see Section 9.4.3)
40071	I/O Module 1 Output 6	RW	WORD	Event Code (see Section 9.4.3)
40072	I/O Module 2 Output 1	RW	WORD	Event Code (see Section 9.4.3)
40073	I/O Module 2 Output 2	RW	WORD	Event Code (see Section 9.4.3)
40074	I/O Module 2 Output 3	RW	WORD	Event Code (see Section 9.4.3)
40075	I/O Module 2 Output 4	RW	WORD	Event Code (see Section 9.4.3)
40076	I/O Module 2 Output 5	RW	WORD	Event Code (see Section 9.4.3)
40077	I/O Module 2 Output 6	RW	WORD	Event Code (see Section 9.4.3)
40078	I/O Module 3 Output 1	RW	WORD	Event Code (see Section 9.4.3)
40079	I/O Module 3 Output 2	RW	WORD	Event Code (see Section 9.4.3)
40080	I/O Module 3 Output 3	RW	WORD	Event Code (see Section 9.4.3)
40081	I/O Module 3 Output 4	RW	WORD	Event Code (see Section 9.4.3)
40082	I/O Module 3 Output 5	RW	WORD	Event Code (see Section 9.4.3)
40083	I/O Module 3 Output 6	RW	WORD	Event Code (see Section 9.4.3)
40084	I/O Module 4 Output 1	RW	WORD	Event Code (see Section 9.4.3)
40085	I/O Module 4 Output 2	RW	WORD	Event Code (see Section 9.4.3)
40086	I/O Module 4 Output 3	RW	WORD	Event Code (see Section 9.4.3)
40087	I/O Module 4 Output 4	RW	WORD	Event Code (see Section 9.4.3)
40088	I/O Module 4 Output 5	RW	WORD	Event Code (see Section 9.4.3)
40089	I/O Module 4 Output 6	RW	WORD	Event Code (see Section 9.4.3)
40090	TSI1 Event	RW	WORD	Event Code (see Section 9.4.3)
40091	TSI2 Event	RW	WORD	Event Code (see Section 9.4.3)
40092	I/O Module 1 Input 1	RW	WORD	Event Code (see Section 9.4.3)
40093	I/O Module 1 Input 2	RW	WORD	Event Code (see Section 9.4.3)
40094	I/O Module 2 Input 1	RW	WORD	Event Code (see Section 9.4.3)
40095	I/O Module 2 Input 2	RW	WORD	Event Code (see Section 9.4.3)
40096	I/O Module 3 Input 1	RW	WORD	Event Code (see Section 9.4.3)
40097	I/O Module 3 Input 2	RW	WORD	Event Code (see Section 9.4.3)
40098	I/O Module 4 Input 1	RW	WORD	Event Code (see Section 9.4.3)
40099	I/O Module 4 Input 2	RW	WORD	Event Code (see Section 9.4.3)
40150	Events 0 - 19	RO	WORD*100	Time, Date, Code (see Section 9.4.3), Param1, Param2
40250	Events 20 - 39	RO	WORD*100	Time, Date, Code (see Section 9.4.3), Param1, Param2
40350	Events 40 - 59	RO	WORD*100	Time, Date, Code (see Section 9.4.3), Param1, Param2

Register	Data Description	Access	Data Type	Range/Units
40450	Events 60 - 79	RO	WORD*100	Time, Date, Code (see Section 9.4.3), Param1, Param2
40550	Events 80 - 99	RO	WORD*100	Time, Date, Code (see Section 9.4.3), Param1, Param2
40600	SCRDOs (software-controlled relay driver outputs)	RW	WORD[0:1]	X0 = Off; X1 = On; 0X = Unassigned; 1X = Assigned
40601	MLB (main logic board) I/O Status	RO	WORD [0:4]	One bit per I/O: Bit 0=Programmable Output Bit 1=Programmable Input #1 Bit 2=Programmable Input #2 Bit 3=Fixed Output LSDO Bit 4=Fixed Output Source 2 Engine Start
40602	I/O Module1 I/O Status	RO	WORD [0:7]	For each I/O module: Bit 0=Programmable Output #1
40603	I/O Module2 I/O Status	RO	WORD [0:7]	Bit 1=Programmable Output #2
40604	I/O Module3 I/O Status	RO	WORD [0:7]	Bit 2=Programmable Output #3
40605	I/O Module4 I/O Status	RO	WORD [0:7]	Bit 3=Programmable Output #4 Bit 4=Programmable Output #5 Bit 5=Programmable Output #6 Bit 6=Programmable Input #1 Bit 7=Programmable Input #2
40650	Active Time Delay Number	RO	WORD	
40651	Active Time Delay Remaining	RO	WORD	Seconds
40652	Active Time Delay Preset	RO	WORD	Seconds
40740	Accessory Setup	RW	WORD [0:15]	0: Enable Engine Start Extended Time Delay 1: Reserved for future use (always 0) 2: Enable In Phase Monitor 3: Reserved for future use (always 0) 4: Commit to Transfer 5: Peak Shave Delay Bypass 6-7: Reserved for future use (always 0) 8: In Phase Transition Angle (0=Lagging; 1=Leading) 9-15: In Phase Transition Angle
40741	No. of I/O Modules	RW	WORD	1-4
40742	Accessory Status	RO	WORD[0:4]	0: Exercise In Progress 1: In Phase Monitor Active 2: Load Shed In Progress 3: Peak Shaving In Progress 4: Test Occurring
40743	DIP Switch Position	RO	WORD[0:4]	0: Transfer Inhibited 1: Loaded/Unloaded Test 2: Exercise Inhibited 3: Loaded/Unloaded Exercise (Push Button Only) (0=Unloaded; 1=Loaded) 4: Exercise Interval (Push Button Only) (0=1 week; 1=2 week)
40750	Before Transfer to Source 1 Mtr Load Discon. Output	RW	WORD	0-3600 Sec
40751	Before Transfer Source 1 Delay #1	RW	WORD	0-3600 Sec
40752	Before Transfer Source 1 Delay #2	RW	WORD	0-3600 Sec
40753	Before Transfer Source 1 Delay #3	RW	WORD	0-3600 Sec
40754	Before Transfer Source 1 Delay #4	RW	WORD	0-3600 Sec
40755	Before Transfer Source 1 Delay #5	RW	WORD	0-3600 Sec
40756	Before Transfer Source 1 Delay #6	RW	WORD	0-3600 Sec

Register	Data Description	Access	Data Type	Range/Units
40757	Before Transfer Source 1 Delay #7	RW	WORD	0-3600 Sec
40758	Before Transfer Source 1 Delay #8	RW	WORD	0-3600 Sec
40759	After Transfer to Source 1 Mtr Load Discon. Output	RW	WORD	0-3600 Sec
40760	After Transfer Source 1 Delay #1	RW	WORD	0-3600 Sec
40761	After Transfer Source 1 Delay #2	RW	WORD	0-3600 Sec
40762	After Transfer Source 1 Delay #3	RW	WORD	0-3600 Sec
40763	After Transfer Source 1 Delay #4	RW	WORD	0-3600 Sec
40764	After Transfer Source 1 Delay #5	RW	WORD	0-3600 Sec
40765	After Transfer Source 1 Delay #6	RW	WORD	0-3600 Sec
40766	After Transfer Source 1 Delay #7	RW	WORD	0-3600 Sec
40767	After Transfer Source 1 Delay #8	RW	WORD	0-3600 Sec
40768	Before Transfer to Source 2 Mtr Load Discon. Output	RW	WORD	0-3600 Sec
40769	Before Transfer Source 2 Delay #1	RW	WORD	0-3600 Sec
40770	Before Transfer Source 2 Delay #2	RW	WORD	0-3600 Sec
40771	Before Transfer Source 2 Delay #3	RW	WORD	0-3600 Sec
40772	Before Transfer Source 2 Delay #4	RW	WORD	0-3600 Sec
40773	Before Transfer Source 2 Delay #5	RW	WORD	0-3600 Sec
40774	Before Transfer Source 2 Delay #6	RW	WORD	0-3600 Sec
40775	Before Transfer Source 2 Delay #7	RW	WORD	0-3600 Sec
40776	Before Transfer Source 2 Delay #8	RW	WORD	0-3600 Sec
40777	After Transfer to Source 2 Mtr Load Discon. Output	RW	WORD	0-3600 Sec
40778	After Transfer Source 2 Delay #1	RW	WORD	0-3600 Sec
40779	After Transfer Source 2 Delay #2	RW	WORD	0-3600 Sec
40780	After Transfer Source 2 Delay #3	RW	WORD	0-3600 Sec
40781	After Transfer Source 2 Delay #4	RW	WORD	0-3600 Sec
40782	After Transfer Source 2 Delay #5	RW	WORD	0-3600 Sec
40783	After Transfer Source 2 Delay #6	RW	WORD	0-3600 Sec
40784	After Transfer Source 2 Delay #7	RW	WORD	0-3600 Sec
40785	After Transfer Source 2 Delay #8	RW	WORD	0-3600 Sec
40800-40864	Common Event Alarms	RW	WORD * 65 [0:15]	0-14: Event code of defined common alarm (DCA) (see Section 9.4.3) 15: 0=Not assigned to DCA; 1= Assigned to DCA
40900	Plant Exerciser Mode	RW	WORD	0 = Push Button Mode; 1 = Calendar Only; 2 = Calendar w/ Override
40901	Length Push Button Exercise	RW	WORD	1-5999 Minutes
40902	Time of Push Button Exercise	RO	WORD	Minutes since midnight
40903	Initial Date of Push Button Exercise	RO	WORD [0:15]	0-4: Day of Month 5-8: Month of Year 9-15: Year + 2000 (2000-2127)
40905	Enabled / Loaded / Interval Code / Repeat Rate Next Cal. Event	RW	WORD[0:8]	0: 0 = Disabled; 1 = Enabled 1: 0 = Unloaded; 1 = Loaded 2-3: Interval Code (00 = DMO; 01 = day; 10 = week; 11 = month) 4-7: Repeat Rate (1-12) 8: 0 = Not Running; 1 = Running (read only)
40906	Start Time Next Cal. Event	RW	WORD	Minutes since midnight

Register	Data Description	Access	Data Type	Range/Units
40907	Start Date Next Cal. Event	RW	WORD [0:15]	0-4: Day of Month
				5-8: Month of Year
				9-15: Year + 2000 (2000-2127)
40908	Run Time Next Cal. Event	RW	WORD	1-5999 Minutes
40910	Enabled / Loaded / Interval Code / Repeat Rate Exer. Event #1	RW	WORD[0:8]	0: 0 = Disabled; 1 = Enabled
				1: 0 = Unloaded; 1 = Loaded
				2-3: Interval Code (00 = DMO; 01 = day; 10 = week; 11 = month)
				4-7: Repeat Rate (1-12)
				8: 0 = Not Running; 1 = Running (read only)
40911	Start Time Exer. Event #1	RW	WORD	Minutes since midnight
40912	Start Date Exer. Event #1	RW	WORD [0:15]	0-4: Day of Month
				5-8: Month of Year
				9-15: Year + 2000 (2000-2127)
40913	Run Time Exer. Event #1	RW	WORD	1-5999 Minutes
40914- 40994	Exer. Events #2-#21 (same as above)	RW	WORD * 80	Same structure as Exer. Event #1
41010	Last Outage Time	RO	WORD	Minutes since midnight
41011	Last Outage Date	RO	WORD [0:15]	0-4: Day of Month
				5-8: Month of Year
				9-15: Year + 2000 (2000-2127)
41012- 41013	Duration of Last Outage	RO	WORD * 2	Minutes
41110- 41119	Designation	RW	WORD * 10	20 ASCII characters
41120- 41129	Load Description	RW	WORD * 10	20 ASCII characters
41130- 41139	Branch Description	RW	WORD * 10	20 ASCII characters
41140- 41149	Location	RW	WORD * 10	20 ASCII characters
41200	ATS Controller Code Revision	RO	WORD [0:15]	0-7: Minor Version
				8-15: Major Version
41201	PIC Code Revision	RO	WORD [0:15]	0-7: Minor Version
				8-15: Major Version
41202	I/O Module1 Code Revision	RO	WORD [0:15]	0-7: Minor Version (return 0 if not installed)
				8-15: Major Version (return 0 if not installed)
41203	I/O Module2 Code Revision	RO	WORD [0:15]	0-7: Minor Version (return 0 if not installed)
				8-15: Major Version (return 0 if not installed)
41204	I/O Module3 Code Revision	RO	WORD [0:15]	0-7: Minor Version (return 0 if not installed)
				8-15: Major Version (return 0 if not installed)
41205	I/O Module4 Code Revision	RO	WORD [0:15]	0-7: Minor Version (return 0 if not installed)
				8-15: Major Version (return 0 if not installed)
41250	Time	RW	WORD	Minutes since midnight
41251	Date (day)	RW	WORD [0:15]	0-4: Day of Month
	Date (month)			5-8: Month of Year
	Date (year)			9-15: Year + 2000 (2000-2127)
41252	Adjust for daylight savings time	RW	WORD [0]	0: 0 = do not adjust; 1 = adjust

Register	Data Description	Access	Data Type	Range/Units
41253	Date to move clock forward (day)	RW	WORD [0:15]	0-4: Day of Month
	Date to move clock forward (month)			5-8: Month of Year
	Date to move clock forward (year)			9-15: Year + 2000 (2000-2127)
41254	Date to move clock backward (day)	RW	WORD [0:15]	0-4: Day of Month
	Date to move clock backward (month)			5-8: Month of Year
	Date to move clock backward (year)			9-15: Year + 2000 (2000-2127)
41300- 41301	Minutes not in Preferred Total	RO	WORD * 2	minutes (most significant word first)
41302- 41303	Minutes not in Preferred since Reset	RO	WORD * 2	minutes (most significant word first)
41304- 41305	Minutes in Standby Total	RO	WORD * 2	minutes (most significant word first)
41306- 41307	Minutes in Standby since Reset	RO	WORD * 2	minutes (most significant word first)
41308- 41309	Minutes of Operation Total	RO	WORD * 2	minutes (most significant word first)
41310- 41311	Minutes of Operation since Reset	RO	WORD * 2	minutes (most significant word first)
41312	Switch Transfers Total	RO	WORD	
41313	Switch Transfers since Reset	RO	WORD	
41314	Failures to Transfer Total	RO	WORD	
41315	Failures to Transfer since Reset	RO	WORD	
41316	Loss of Preferred Transfers Total	RO	WORD	
41317	Loss of Preferred Transfers since Reset	RO	WORD	
41318	Transfer Time N->E	RO	WORD	milliseconds
41319	Transfer Time E->N	RO	WORD	milliseconds
41320	System Start Date	RO	WORD [0:15]	0-4: Day of Month
				5-8: Month of Year
				9-15: Year + 2000 (2000-2127)
41321	Last Maintenance Date	RO	WORD [0:15]	0-4: Day of Month
				5-8: Month of Year
				9-15: Year + 2000 (2000-2127)
41350	Maintenance/Test & Manual Actions	WO	WORD [0:9]	0: Reset Maintenance Records
				1: Start Peak Shave
				2: End Peak Shave
				3: Start Remote Test
				4: End Remote Test
				5: Force Transfer to OFF
				6: Resume Program Trans. Operation
				7: End Current Time Delay
				8: Remote Manual Exercise Start
9: Remote Manual Exercise End				
41351	Clear Event Log	WO	WORD[0]	0: 1=Clear Log
41352	Disable Manual Exercise	RW	WORD[0]	0: 0=Enabled; 1=Disabled
49999	Device ID	RO	WORD	MPAC ®1000 ATS controller= 19

9.4.3 Event Codes

Event codes are used in the Event History registers 40150-40599.

Code	Description
1	End Time Delay Button
2	Test Button
3	Exercise Button
4	Lamp Test Button
5	Service Required Reset
6	Exerciser Set
7	Maintenance DIP Switch
8	Exerciser Loaded DIP Switch
9	Test Loaded DIP Switch
10	One/Two Week DIP Switch
11	Disable Exercise DIP Switch
12	Supervised Switch in Manual
13	Supervised Immediate Transfer
14	Supervised Switch in Auto
15	Source N Preferred
16	Source E Preferred
17-45	<i>Reserved</i>
46	I/O Module Timeout
47	I/O Module Bus Error
48-54	<i>Reserved for future use</i>
55	No Function Defined
56	Preferred Source Available
57	Standby Source Available
58	Contactors in Preferred Position
59	Contactors in Standby Position
60	Contactors in Off Position
61	Contactors in Source N Position
62	Contactors in Source E Position
63	Not in Auto
64	Load Control Active
65	Low Battery on Standby Source
66	Exerciser Started
67	Test Mode Active
68	Peak Shave Active
69	Non-Emergency Transfer
70	Load Bank Activate
71	Start Source N Generator
72	Start Source E Generator
73	In Phase Monitor Waiting for Synch
74	Common Alarm
75	Source N Under Voltage
76	Source N Over Voltage
77	Source N Loss of Phase
78	Source N Phase Rotation Error
79	Source N Over Frequency
80	Source N Under Frequency

Code	Description
81	Source E Under Voltage
82	Source E Over Voltage
83	Source E Loss of Phase
84	Source E Phase Rotation Error
85	Source E Over Frequency
86	Source E Under Frequency
87	Failure to Acquire Standby
88	Failure to Transfer
89	I/O Module Comms Lost
90	I/O Module Not Found
91	I/O Module Not Installed
92	Aux. Switch Fault
93	Aux. Switch Open
94	Load Control Output #0
95	Load Control Output #1
96	Load Control Output #2
97	Load Control Output #3
98	Load Control Output #4
99	Load Control Output #5
100	Load Control Output #6
101	Load Control Output #7
102	Load Control Output #8
103	Modbus Controlled RDO #1
104	Modbus Controlled RDO #2
105	Modbus Controlled RDO #3
106	Modbus Controlled RDO #4
107	3 Source System Disable
108-114	<i>Reserved for future use</i>
115	No Function Defined
116	Forced Transfer to Off
117	Peak Shave Mode
118	Inhibit Transfer
119	Remote End Time Delay
120	Remote Test
121	Low Battery Voltage
122	Remote Common Alarm
123	Bypass Contactor Disable
124	3 Source System Disable
125-131	<i>Reserved for future use</i>
132	Contactors Moved
133	EEPROM Access Warning
134	Internal Fault
135	System Ready
136	Critical Service Required
137	Non-Critical Service Required
138	System Parameter Changed
139	Source N Available
140	Source E Available
141	Over Frequency Source E

Code	Description
142	Under Frequency Source E
143	Loss of Phase Source E
144	Phase Rotation Error Source E
145	Over Voltage L1-L2 Source E
146	Over Voltage L2-L3 Source E
147	Over Voltage L3-L1 Source E
148	Under Voltage L1-L2 Source E
149	Under Voltage L2-L3 Source E
150	Under Voltage L3-L1 Source E
151-201	<i>Reserved</i>
202	Partial Meter Read
203-209	<i>Reserved for future use</i>
210	History Read from EEPROM
212	DCA Read from EEPROM
213	Exercise Time Updated
214	Network Settings Updated
211	Settings Read from EEPROM
215	Transfer Mode Changed
216	Default History Loaded
217	Default Settings Loaded
218	Default Common Alarms Loaded
219-222	<i>Reserved for future use</i>
223	Modbus Force Transfer to Off
224	Modbus Peak Shave
225	Modbus System Test
232	System Ready

Notes

Section 10 MPAC 1500 ATS Controller

10.1 Specifications

The MPAC™ 1500 controller's Modbus® communication capability:

- Supports industry-standard Modbus® RTU protocol through the RS-485 serial ports.
- Uses Modbus® TCP protocol through the Ethernet port.
- Uses RS-485 connections to a single Modbus® master or a network of devices.
- Connects directly to an Ethernet network (RJ-45 connector on the main logic board).
- Uses standard baud rates of 9600, 19200, or 57600.

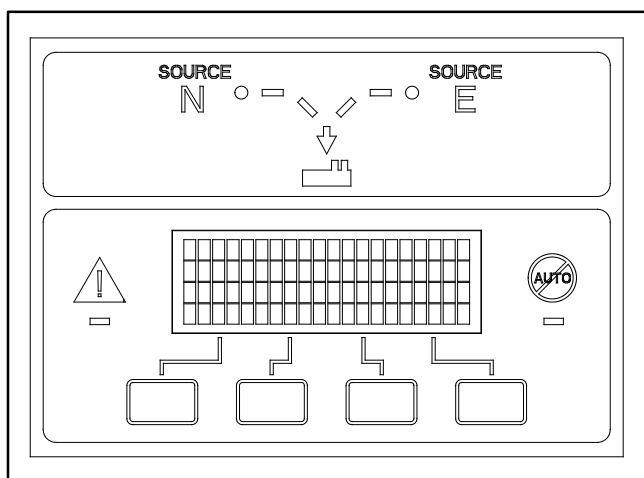
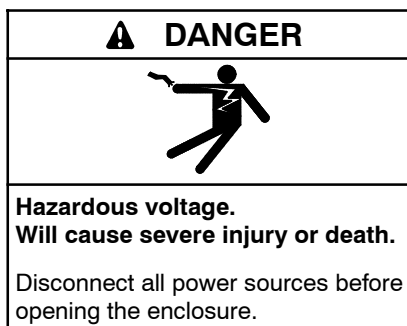

Figure 10-1 MPAC™ 1500 Controller Identification

10.2 Hardware Connections



Servicing the transfer switch. Hazardous voltage can cause severe injury or death. Deenergize all power sources before servicing. Turn off the main circuit breakers of all transfer switch power sources and disable all generator sets as follows: (1) Move all generator set master controller

switches to the OFF position. (2) Disconnect power to all battery chargers. (3) Disconnect all battery cables, negative (-) leads first. Reconnect negative (-) leads last when reconnecting the battery cables after servicing. Follow these precautions to prevent the starting of generator sets by an automatic transfer switch, remote start/stop switch, or engine start command from a remote computer. Before servicing any components inside the enclosure: (1) Remove all jewelry. (2) Stand on a dry, approved electrically insulated mat. (3) Test circuits with a voltmeter to verify that they are deenergized.

NOTICE

Electrostatic discharge damage. Electrostatic discharge (ESD) damages electronic circuit boards. Prevent electrostatic discharge damage by wearing an approved grounding wrist strap when handling electronic circuit boards or integrated circuits. An approved grounding wrist strap provides a high resistance (about 1 megohm), *not a direct short*, to ground.

The controller uses a non-isolated RS-485 port with connection speeds of 9.6, 19.2, and 57.6 kbps.

1. Disconnect power to the transfer switch by opening switches or circuit breakers before opening the enclosure.
2. Ethernet connection: Use CAT5 network cable to connect to RJ-45 connector P13 on the controller. See Figure 10-2 for the connector location.

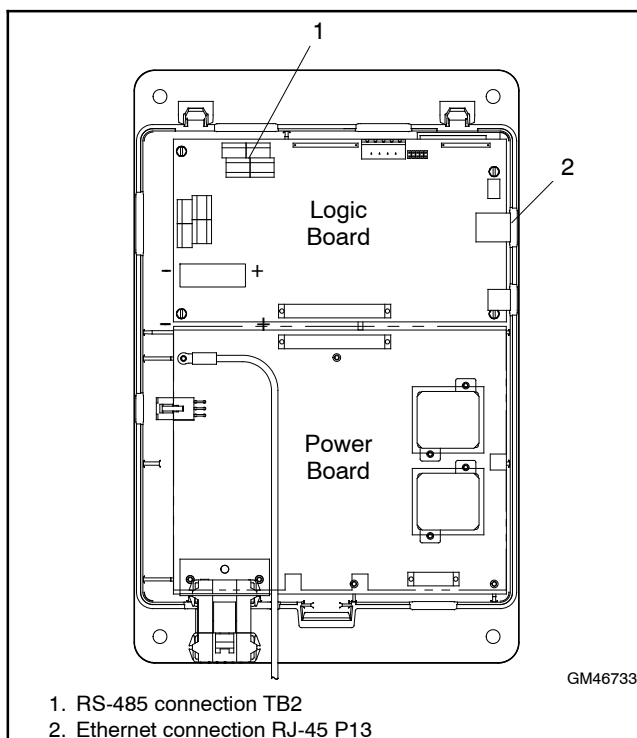

Figure 10-2 ATS Controller, Cover Removed

3. RS-485 connection:

- a. Remove the controller housing cover to gain access to connector TB2.. See Figure 10-2.
- b. Use #12-24 AWG twisted-pair shielded cable; Belden cable #9841 or equivalent is recommended. Connect the Modbus® input and output to terminal strip TB2. See Figure 10-3. Connect A to negative (-), B to positive (+), and the shield to ground as shown in Figure 10-3.
- c. Tighten the connections to 0.5 Nm (4.4 in. lb.).
- d. Replace the controller housing cover.

- 4. Close and lock the transfer switch enclosure door before reconnecting the power.

Note: Install communication conductors in raceways, cables, or conduit separate from AC power conductors.

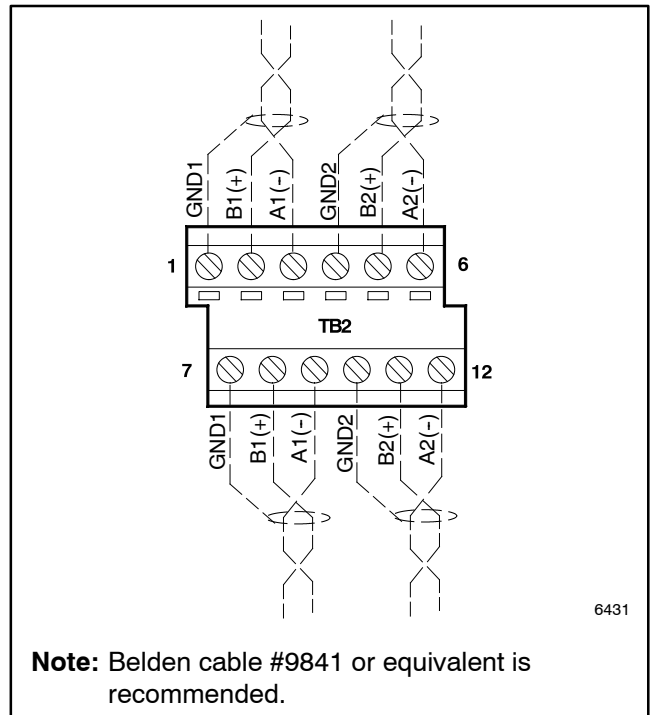

Figure 10-3 RS-485 Connections

10.3 Controller Setup

Set the controller communications settings through the controller user interface. Navigate to the Communications Setup screen and set the parameters for serial or ethernet communication as shown in Figure 10-4. Refer to the ATS Operation/Installation for more detailed instructions. See List of Related Materials in the Introduction to this manual.

Set the baud rate of the Modbus® network interface port to match the other devices in the network. Allowable baud rates are 9600, 19200, and 57600 baud.

Choose a unique network address for each device in the network.

The MPAC™ 1500 controller does not operate as a Modbus-to-Ethernet converter for other devices in a network. For multiple device networks connected to the personal computer through the Ethernet, use a Modbus-to-Ethernet converter for the other devices in the network. See TT-1405, provided with the converter, for connection instructions.

Setting	Range	Needed for Connection Type:			Notes
		Serial	Remote Serial (modem)	Ethernet	
Modbus Server TCP	Enabled or Disabled			X	Enable for network communication through the ethernet port.
Modbus Server Port 1	Enabled or Disabled	X	X		Enable for Modbus communication through serial port 1 on the main logic board.
Modbus Server Port 2	Enabled or Disabled	X	X		Enable for Modbus communication through serial port 2 on the main logic board.
Modbus Addr Port 1	001-247 default 1	X	X		Address for RS-485 serial port 1 (on the main logic board). Each port must have a different address.
Modbus Addr Port 2	001-247 default 2	X	X		Address for RS-485 serial port 2 (on the main logic board). Each port must have a different address.
Baud Rate Port 1	9600, 19200, 57600	X	X		Baud rate in bits per second for serial communication between the controller and a personal computer's COM port. All devices in a network must use the same baud rate.
Baud Rate Port 2	9600, 19200, 57600	X	X		
Modbus TCP Unit ID				X	Factory-set to 3. A unit ID is required for Modbus over TCP communication. The unit ID for TCP communication is analogous to the Modbus address for serial communication through the RS-485 ports.
IP Address				X	Obtain from your local network administrator. Every device on the network must have a unique IP address.
Subnet Mask				X	Obtain from your local network administrator.
MAC Address	Factory-set	—	—	X	Hardware address, entered at the factory. Not adjustable. Appears only in the Communications View on the controller's display.

Figure 10-4 Communication Settings

10.4 Modbus Registers

Refer to Section 1.3 for definitions of terms and symbols used in the register tables.

Time delays, setpoints, inputs and outputs, and other user-defined parameters are programmed using the Setup Program. Refer to the Setup Program Operation Manual for instructions. See the List of Related Materials for document part numbers.

10.4.1 Guide to the Register Map

Description	Registers
Monitoring	40001-40054
Setup *	40057-40058
Time delays	400059-40077
Trip point settings	40078-40107
Outputs (event code)	40108-40153
Modules types	40154-40161
I/O status	40194-40255
Remote I/O descriptions	40260-40349
Accessories	40740-40742
DIP switch positions	40743
Pre/post transfer delays	40750-40787
Common alarms	40800-40864
Exerciser	40905-40994
Last outage	41010-41013
Customer-defined descriptions †	41110-41149
Password-protected factory settings *	41150-41167
Code versions	41200-41201
MAC address	41202
Time/date	41250-41254
Maintenance history	41300-41320
Manual operations	41350-41352
Event history	42150-42854
Calibration *	43400-43429
Device ID	49999

* Distributor-level password required to write to these registers
† Descriptions entered through Monitor III software

10.4.2 Passwords

Note: Password-protected parameters are factory-set and should not require changes unless the transfer switch controller is replaced.

If the transfer switch controller needs replacement, some password-protected settings may need to be changed after the new controller assembly is installed. Setup registers, serial numbers, and calibration registers require the distributor-level password, which is not the same as the setup or test passwords for the transfer switch. Distributors must contact the Kohler Power Systems Service Department to obtain the distributor-level password.

Send the data register and the password in the same request. For example, send register 43400 and 43401 together to change the calibration of the L1L2N (normal source) voltage.

10.4.3 Modbus Registers

Register	Data Description	Access	Data Type	Range/Units
40001	System Overview	RO	WORD [0:14]	0-1: Contactor Position (00 = Off; 01 = Normal; 10 = Emerg; 11 = Fault) 2: Preferred Source (0 = Source1; 1= Source2) 3-12: Top Event on Warning Stack 13: Preferred Source Available (0 = No, 1 = Yes) 14: Standby Source Available (0 = No, 1 = Yes) 15: Reserved for future use (always 0)
40002	Source N Line-Neutral L1-L0	RO	WORD	Volts AC * 10
40003	Source N Line-Neutral L2-L0	RO	WORD	Volts AC * 10
40004	Source N Line-Neutral L3-L0	RO	WORD	Volts AC * 10
40005	Source E Line-Neutral L1-L0	RO	WORD	Volts AC * 10
40006	Source E Line-Neutral L2-L0	RO	WORD	Volts AC * 10
40007	Source E Line-Neutral L3-L0	RO	WORD	Volts AC * 10
40008	Source N Line Voltage L1-L2	RO	WORD	Volts AC * 10
40009	Source N Line Voltage L2-L3	RO	WORD	Volts AC * 10
40010	Source N Line Voltage L3-L1	RO	WORD	Volts AC * 10
40011	Source E Line Voltage L1-L2	RO	WORD	Volts AC * 10
40012	Source E Line Voltage L2-L3	RO	WORD	Volts AC * 10
40013	Source E Line Voltage L3-L1	RO	WORD	Volts AC * 10
40014	Source N Frequency	RO	WORD	Hz * 10
40015	Source E Frequency	RO	WORD	Hz * 10
40016	Current L1	RO	WORD	Amps * 10
40017	Current L2	RO	WORD	Amps * 10
40018	Current L3	RO	WORD	Amps * 10
40019	Closed Transition In Phase Degree Delta	RO	WORD	Degrees
40020- 40038	Reserved for future use	—	—	Return 0
40039	Closed-Programmed Transition Override Mode	RW	WORD	0 = Auto Override, 1 = Non-Automatic
40040	Password for writing register 40042	WO	WORD	0-32768
40041	Synchronous Voltage Phase Angle	RO	WORD	0-10 degrees
40042	Synchronous Voltage Differential	RW	WORD	0%-5%
40043	Synchronous Frequency Differential	RW	WORD	0.0Hz.-0.3Hz. (Hz * 0.1)
40044	Service Entrance Type	RW	WORD	0 = None; 1 = Insulated Case Circuit Breaker, 2 = Molded Case Circuit Breaker, 3 = Contactor
40045	Phase Rotation Actual	RO	WORD	0 = disabled; 1 = ABC; 2 = CBA (MSB = Normal; LSB = Emerg.)
40046	Phase Rotation Expected	RW	WORD	0 = disabled; 1 = ABC; 2 = CBA
40047	Nominal Normal Voltage	RW	WORD	Volts AC * 10
40048	Nominal Emergency Voltage	RW	WORD	Volts AC * 10
40049	Nominal Normal Frequency	RW	WORD	Hz * 10
40050	Nominal Emergency Frequency	RW	WORD	Hz * 10
40051	Normal Number of Phases	RW	WORD	1 or 3
40052	Emergency Number of Phases	RW	WORD	1 or 3
40053	Rated Amperage	RW	WORD	0-4000
40054	Reserved for future use	—	—	Return 0
40055	Proprietary	—	—	—
40056	Proprietary	—	—	—

Register	Data Description	Access	Data Type	Range/Units
40057	Transition Mode	RW	WORD [0:4]	0-1: 00 = Open; 01 = Programmed; 10 = Closed; 11 = Reserved
	Mode of Operation			2-3: 01 = Genset to Util; 10 = Util to Util; 00 = Genset to Genset; 11 = Util to Gen-Gen
	Supervised Transfer Control Switch Position			4: 0 = Auto; 1 = Manual
40058	Password for writing register 40057	WO	WORD	0 - 32768
40059	Normal Engine Start Time Delay	RW	WORD	0-10 sec
40060	Emergency Engine Start Time Delay	RW	WORD	0-10 sec
40061	Normal Ext. Engine Start Time Delay	RW	WORD	0-3600 sec
40062	Emergency Ext. Engine Start Time Delay	RW	WORD	0-3600 sec
40063	Normal Engine Cooldown	RW	WORD	0-3600 sec
40064	Emergency Engine Cooldown	RW	WORD	0-3600 sec
40065	Standby to Preferred	RW	WORD	0-3600 sec
40066	Preferred to Standby	RW	WORD	0-3600 sec
40067	Off (Preferred to Standby - Prog. Transition)	RW	WORD	0-3600 sec
40068	Off (Standby to Preferred - Prog. Transition)	RW	WORD	0-3600 sec
40069	Fail to Acquire Preferred	RW	WORD	1-3600 sec (1-300 sec for closed transition)
40070	Fail to Acquire Standby	RW	WORD	1-3600 sec (1-300 sec for closed transition)
40071	Fail to Synchronize	RW	WORD	1-3600 sec
40072	Fail to Synch. Enable	RW	WORD	0 = disabled; 1 = enabled
40073	Reserved for future use	—	—	Return 0
40074	Reserved for future use	—	—	Return 0
40075	Active Time Delay #	RO	WORD	
40076	Active Time Delay Remaining	RO	WORD	Seconds * 10
40077	Active Time Delay Preset	RO	WORD	Seconds * 10
40078	Normal Over Voltage Dropout	RW	WORD	105%-135% of Nominal
40079	Normal Over Voltage Pickup	RW	WORD	95%-100% of Nominal
40080	Normal Under Voltage Pickup	RW	WORD	85%-100% of Nominal
40081	Normal Under Voltage Dropout	RW	WORD	75%-98% of Pickup
40082	Normal Unbalance Enabled	RW	WORD	0 = disabled; 1 = enabled
40083	Normal Unbalance Voltage Dropout	RW	WORD	5%-20%
40084	Normal Unbalance Voltage Pickup	RW	WORD	3%-18%
40085	Normal Voltage Debounce Time	RW	WORD	0.1 - 9.9 sec * 10
40086	Emergency Over Voltage Dropout	RW	WORD	105%-135% of Nominal
40087	Emergency Over Voltage Pickup	RW	WORD	95%-100% of Nominal
40088	Emergency Under Voltage Pickup	RW	WORD	85%-100% of Nominal
40089	Emergency Under Voltage Dropout	RW	WORD	75%-98% of Pickup
40090	Emergency Unbalance Enabled	RW	WORD	0 = disabled; 1 = enabled
40091	Emergency Unbalance Voltage Dropout	RW	WORD	5%-20%
40092	Emergency Unbalance Voltage Pickup	RW	WORD	3%-18%
40093	Emergency Voltage Debounce Time	RW	WORD	0.1 - 9.9 sec * 10
40094	Normal Over Freq Dropout	RW	WORD	101%-105% of Pickup
40095	Normal Over Freq Pickup	RW	WORD	105%-120% of Nominal
40096	Normal Under Freq Dropout	RW	WORD	95%-99% of Pickup
40097	Normal Under Freq Pickup	RW	WORD	80%-95% of Nominal
40098	Normal Freq Dropout Time	RW	WORD	0.1 - 15.0 sec * 10
40099	Emergency Over Freq Dropout	RW	WORD	101%-105% of Pickup

Register	Data Description	Access	Data Type	Range/Units
40100	Emergency Over Freq Pickup	RW	WORD	105%-120% of Nominal
40101	Emergency Under Freq Dropout	RW	WORD	95%-99% of Pickup
40102	Emergency Under Freq Pickup	RW	WORD	80%-95% of Nominal
40103	Emergency Freq Dropout Time	RW	WORD	0.1 - 15.0 sec * 10
40104	Reserved for future use	—	—	Return 0
40105	Reserved for future use	—	—	Return 0
40106	Reserved for future use	—	—	Return 0
40107	Reserved for future use	—	—	Return 0
40108	MLB Programmable Output #1	RW	WORD	Event Code
40109	MLB Programmable Output #2	RW	WORD	Event Code
40110	Reserved for future use	—	—	Return 0
40111	MLB Programmable Input #1	RW	WORD	Event Code
40112	MLB Programmable Input #2	RW	WORD	Event Code
40113	Reserved for future use	—	—	Return 0
40114	Expansion Board Address 1 Output #1	RW	WORD	Event Code
40115	Expansion Board Address 1 Output #2	RW	WORD	Event Code
40116	Expansion Board Address 1 Output #3	RW	WORD	Event Code
40117	Expansion Board Address 1 Output #4	RW	WORD	Event Code
40118	Expansion Board Address 1 Output #5	RW	WORD	Event Code
40119	Expansion Board Address 1 Output #6	RW	WORD	Event Code
40120	Expansion Board Address 2 Output #1	RW	WORD	Event Code
40121	Expansion Board Address 2 Output #2	RW	WORD	Event Code
40122	Expansion Board Address 2 Output #3	RW	WORD	Event Code
40123	Expansion Board Address 2 Output #4	RW	WORD	Event Code
40124	Expansion Board Address 2 Output #5	RW	WORD	Event Code
40125	Expansion Board Address 2 Output #6	RW	WORD	Event Code
40126	Expansion Board Address 3 Output #1	RW	WORD	Event Code
40127	Expansion Board Address 3 Output #2	RW	WORD	Event Code
40128	Expansion Board Address 3 Output #3	RW	WORD	Event Code
40129	Expansion Board Address 3 Output #4	RW	WORD	Event Code
40130	Expansion Board Address 3 Output #5	RW	WORD	Event Code
40131	Expansion Board Address 3 Output #6	RW	WORD	Event Code
40132	Expansion Board Address 4 Output #1	RW	WORD	Event Code
40133	Expansion Board Address 4 Output #2	RW	WORD	Event Code
40134	Expansion Board Address 4 Output #3	RW	WORD	Event Code
40135	Expansion Board Address 4 Output #4	RW	WORD	Event Code
40136	Expansion Board Address 4 Output #5	RW	WORD	Event Code
40137	Expansion Board Address 4 Output #6	RW	WORD	Event Code
40138-40143	Reserved for future use	—	—	Return 0
40144	Expansion Board Address 1 Input #1	RW	WORD	Event Code
40145	Expansion Board Address 1 Input #2	RW	WORD	Event Code
40146	Expansion Board Address 2 Input #1	RW	WORD	Event Code
40147	Expansion Board Address 2 Input #2	RW	WORD	Event Code
40148	Expansion Board Address 3 Input #1	RW	WORD	Event Code
40149	Expansion Board Address 3 Input #2	RW	WORD	Event Code
40150	Expansion Board Address 4 Input #1	RW	WORD	Event Code
40151	Expansion Board Address 4 Input #2	RW	WORD	Event Code
40152	Reserved for future use	—	—	Return 0
40153	Reserved for future use	—	—	Return 0

Register	Data Description	Access	Data Type	Range/Units
40154	Expansion Board Address 1 Board Type	RO	WORD	0 = No Board Installed; 1 = Standard; 2 = Power
40155	Expansion Board Address 2 Board Type	RO	WORD	0 = No Board Installed; 1 = Standard; 2 = Power
40156	Expansion Board Address 3 Board Type	RO	WORD	0 = No Board Installed; 1 = Standard; 2 = Power
40157	Expansion Board Address 4 Board Type	RO	WORD	0 = No Board Installed; 1 = Standard; 2 = Power
40158	Reserved for future use	—	—	Return 0
40159	Reserved for future use	—	—	Return 0
40160	Alarm Option Board	RO	WORD	0 = No Board Installed; 1 = Normal; 2 = Chicago; 3 = Silence
40161	Battery Option Board Installed	RO	WORD	0 = No Board Installed; 1 = Installed
40162-40193	Reserved for future use	—	—	Return 0
40194	MLB Output State	RO	WORD [0:1]	One bit per output
40195	MLB Input State	RO	WORD [0:1]	One bit per input
40196	Expansion Board #1 Outputs State	RO	WORD [0:X]	One bit per output
40197	Expansion Board #2 Outputs State	RO	WORD [0:X]	
40198	Expansion Board #3 Outputs State	RO	WORD [0:X]	
40199	Expansion Board #4 Outputs State	RO	WORD [0:X]	
40200	Expansion Board #1 Inputs State	RO	WORD [0:1]	One bit per input
40201	Expansion Board #2 Inputs State	RO	WORD [0:1]	
40202	Expansion Board #3 Inputs State	RO	WORD [0:1]	
40203	Expansion Board #4 Inputs State	RO	WORD [0:1]	
40250	Software Controlled Outputs State	RW	WORD [0:3]	One bit per output
40251	Software Controlled Outputs Assigned	RO	WORD [0:3]	One bit per output
40252	Remote Monitoring Input State	RO	WORD [0:4]	One bit per input
40253	Remote Monitoring Input Assigned	RO	WORD [0:4]	One bit per input
40260-40269	SCO #1 Description	RW	WORD*10	Software controller output
40270-40279	SCO #2 Description	RW	WORD*10	
40280-40289	SCO #3 Description	RW	WORD*10	
40290-40299	SCO #4 Description	RW	WORD*10	
40300-40309	Reserved for future use	—	—	Return 0 (all registers)
40310-40319	Remote Monitored Input #1 Description	RW	WORD*10	
40320-40329	Remote Monitored Input #2 Description	RW	WORD*10	

Register	Data Description	Access	Data Type	Range/Units
40330-40339	Remote Monitored Input #3 Description	RW	WORD*10	
40340-40349	Remote Monitored Input #4 Description	RW	WORD*10	
40350-40359	Reserved for future use	—	—	Return 0 (all registers)
40600-40698	Reserved for future use	—	—	Return 0 (all registers)
40699	Proprietary	—	—	
40700	Proprietary	—	—	
40740	Accessory Setup	RW	WORD [0:15]	0: Enable Engine Start Extended Time Delay 1: Reserved for future use (always 0) 2: Enable In Phase Monitor 3: Remote Test Loading (0=Loaded; 1=Unloaded) 4: Commit to Transfer 5: Peak Shave Delay Bypass 6: 3-Source Eng. Start Mode (0=pref. first; 1=both @ same time) 7: 3-source Pref. Source Toggle 8: In Phase Transition Angle (0=Lagging; 1=Leading) 9-15: In Phase Transition Angle
40741	Reserved for future use	—	—	Return 0
40742	Accessory Status	RO	WORD [0:6]	0: Exercise In Progress 1: In Phase Monitor Active 2: Load Control In Progress 3: Peak Shaving In Progress 4: Loaded Test Occurring 5: Unloaded Test Occurring 6: Auto-Loaded Test Occurring
40743	DIP Switch Position	RO	WORD [0:4]	0: Maintenance Mode 1: Password Disabled 2: Spare 3 On 3: Spare 4 On
40744	Reserved for future use	—	—	Return 0
40750	Load Shed: Source N Disconnect Time#1	RW	WORD	0-3600 Sec
40751	Load Shed: Source N Disconnect Time#2	RW	WORD	0-3600 Sec
40752	Load Shed: Source N Disconnect Time#3	RW	WORD	0-3600 Sec
40753	Load Shed: Source N Disconnect Time#4	RW	WORD	0-3600 Sec
40754	Load Shed: Source N Disconnect Time#5	RW	WORD	0-3600 Sec
40755	Load Shed: Source N Disconnect Time#6	RW	WORD	0-3600 Sec
40756	Load Shed: Source N Disconnect Time#7	RW	WORD	0-3600 Sec
40757	Load Shed: Source N Disconnect Time#8	RW	WORD	0-3600 Sec

Register	Data Description	Access	Data Type	Range/Units
40758	Load Shed: Source N Disconnect Time#9	RW	WORD	0-3600 Sec
40759	Load Shed: Source E Reconnect Time #1	RW	WORD	0-3600 Sec
40760	Load Shed: Source E Reconnect Time #2	RW	WORD	0-3600 Sec
40761	Load Shed: Source E Reconnect Time #3	RW	WORD	0-3600 Sec
40762	Load Shed: Source E Reconnect Time #4	RW	WORD	0-3600 Sec
40763	Load Shed: Source E Reconnect Time #5	RW	WORD	0-3600 Sec
40764	Load Shed: Source E Reconnect Time #6	RW	WORD	0-3600 Sec
40765	Load Shed: Source E Reconnect Time #7	RW	WORD	0-3600 Sec
40766	Load Shed: Source E Reconnect Time #8	RW	WORD	0-3600 Sec
40767	Load Shed: Source E Reconnect Time #9	RW	WORD	0-3600 Sec
40768	Load Shed: Source E Disconnect Time #1	RW	WORD	0-3600 Sec
40769	Load Shed: Source E Disconnect Time #2	RW	WORD	0-3600 Sec
40770	Load Shed: Source E Disconnect Time #3	RW	WORD	0-3600 Sec
40771	Load Shed: Source E Disconnect Time #4	RW	WORD	0-3600 Sec
40772	Load Shed: Source E Disconnect Time #5	RW	WORD	0-3600 Sec
40773	Load Shed: Source E Disconnect Time #6	RW	WORD	0-3600 Sec
40774	Load Shed: Source E Disconnect Time #7	RW	WORD	0-3600 Sec
40775	Load Shed: Source E Disconnect Time #8	RW	WORD	0-3600 Sec
40776	Load Shed: Source E Disconnect Time #9	RW	WORD	0-3600 Sec
40777	Load Shed: Source N Reconnect Time #1	RW	WORD	0-3600 Sec
40778	Load Shed: Source N Reconnect Time #2	RW	WORD	0-3600 Sec
40779	Load Shed: Source N Reconnect Time #3	RW	WORD	0-3600 Sec
40780	Load Shed: Source N Reconnect Time #4	RW	WORD	0-3600 Sec
40781	Load Shed: Source N Reconnect Time #5	RW	WORD	0-3600 Sec
40782	Load Shed: Source N Reconnect Time #6	RW	WORD	0-3600 Sec
40783	Load Shed: Source N Reconnect Time #7	RW	WORD	0-3600 Sec
40784	Load Shed: Source N Reconnect Time #8	RW	WORD	0-3600 Sec
40785	Load Shed: Source N Reconnect Time #9	RW	WORD	0-3600 Sec

Register	Data Description	Access	Data Type	Range/Units
40786	Load Shed: Source N Number of Loads to Add	RW	WORD	1-9
40787	Load Shed: Source E Number of Loads to Add	RW	WORD	1-9
40788-40799	Reserved for future use	—	—	Return 0 (all registers)
40800-40864	Common Event Alarms	RW	WORD* 65 [0:15]	0-12: Msg Code of defined common alarm
				13: 0=Not audible alarm; 1 = Audible alarm
				14: 0=Not assigned to DCA #2; 1= Assigned to DCA #2
				15: 0=Not assigned to DCA #1; 1= Assigned to DCA #1
40900	Reserved for future use	—	—	Return 0
40901	Reserved for future use	—	—	Return 0
40902	Reserved for future use	—	—	Return 0
40903	Reserved for future use	—	—	Return 0
40905	Enabled / Loaded / Interval Code / Repeat Rate Next Cal. Event	RW	WORD [0:7]	0: 0 = Disabled; 1 = Enabled
				1: 0 = Unloaded; 1 = Loaded
				2-3: Interval Code (00 = DMO; 01 = day; 10 = week; 11 = month)
				4-7: Repeat Rate (1-12)
				8: 0 = Not Running; 1 = Running (read only)
40906	Start Time Next Cal. Event	RW	WORD	Minutes since midnight
40907	Start Date Next Cal. Event	RW	WORD [0:15]	0-4: Day of Month
				5-8: Month of Year
				9-15: Year + 2000 (2000-2128)
40908	Run Time Next Cal. Event	RW	WORD	1-5999 Minutes
40909	Reserved for future use	—	—	Return 0
40910	Enabled / Loaded / Interval Code / Repeat Rate Exer. Event #1	RW	WORD [0:7]	0: 0 = Disabled; 1 = Enabled
				1: 0 = Unloaded; 1 = Loaded
				2-3: Interval Code (00 = DMO; 01 = day; 10 = week; 11 = month)
				4-7: Repeat Rate (1-12)
				8: 0 = Not Running; 1 = Running (read only)
9: 0 = N source; 1 = E source (Gen-Gen Only)				
40911	Start Time Exer. Event #1	RW	WORD	Minutes since midnight
40912	Start Date Exer. Event #1	RW	WORD [0:15]	0-4: Day of Month
				5-8: Month of Year (Jan = 1, Feb = 2,... Dec = 12)
				9-15: Year + 2000 (2001-2128)
40913	Run Time Exer. Event #1	RW	WORD	1-5999 Minutes
40914-40994	Exer. Events #2-#21 (same as above)	RW	WORD * 80	Same structure as Exer. Event #1
40995-40999	Reserved for future use	—	—	Return 0 (all registers)
41010	Last Outage Time	RO	WORD	Minutes since midnight
41011	Last Outage Date	RO	WORD [0:15]	0-4: Day of Month
				5-8: Month of Year
				9-15: Year + 2000 (2000-2128)
41012-41013	Duration of Last Outage	RO	WORD * 2	Minutes
41110-41119	Designation	RW	WORD * 10	20 ASCII characters

Register	Data Description	Access	Data Type	Range/Units
41120-41129	Load Description	RW	WORD * 10	20 ASCII characters
41130-41139	Branch Description	RW	WORD * 10	20 ASCII characters
41140-41149	Location	RW	WORD * 10	20 ASCII characters
41150-41154	ATS Serial Number	RW	WORD * 5	10 ASCII characters
41155	Password for registers 41150-41154	WO	WORD	0 - 32768
41156-41160	Controller Serial Number (FACTORY ONLY)	RW	WORD * 5	10 ASCII characters
41161	Password for registers 41156-41160	WO	WORD	0 - 32768 (FACTORY ONLY)
41162-41166	Contactors Serial Number	RW	WORD * 5	10 ASCII characters
41167	Password for registers 41162-41166	WO	WORD	0 - 32768
41168-41187	Reserved for future use	—	—	Return 0 (all registers)
41200	1500 Code Revision	RO	WORD [0:15]	0-7: Minor Version
				8-15: Major Version
41201	FPGA Revision	RO	WORD	0-7: Minor Version
41202	MAC Address (least significant bits only)	RO	WORD [0:14]	Bits 0-14 only
41250	Time	RW	WORD	Minutes since midnight
41251	Date (day)	RW	WORD [0:15]	0-4: Day of Month
	Date (month)			5-8: Month of Year (Jan = 1, Feb = 2, ... Dec = 12)
	Date (year)			9-15: Year + 2000 (2001-2128)
41252	Adjust for daylight savings time	RW	WORD [0]	0: 0 = do not adjust; 1 = adjust
41253	Date to move clock forward (day of week)	RW	WORD [0:9]	0-2: Day of Month (Sun = 0, Mon = 1, ... Sat = 6)
	Date to move clock forward (month)			3-6: Month of Year (Jan = 1, Feb = 2, ... Dec = 12)
	Date to move clock forward (week of month)			7-9: Week of Month (1 - 4 only)
41254	Date to move clock backward (day of week)	RW	WORD [0:9]	0-2: Day of Month (Sun = 0, Mon = 1, ... Sat = 6)
	Date to move clock backward (month)			3-6: Month of Year (Jan = 1, Feb = 2, ... Dec = 12)
	Date to move clock backward (week of month)			7-9: Week of Month (1 - 4 only)
41255-41260	Reserved for future use	—	—	Return 0 (all registers)
41295	Close Transition Parallel Time	RO	WORD	milliseconds
41296	Transfer Time N->Open	RO	WORD	milliseconds
41297	Transfer Time N->Close	RO	WORD	milliseconds
41298	Transfer Time E->Open	RO	WORD	milliseconds
41299	Transfer Time E->Close	RO	WORD	milliseconds
41300-41301	Minutes not in Preferred Total	RO	WORD * 2	minutes (most significant word first)
41302-41303	Minutes not in Preferred since Reset	RO	WORD * 2	minutes (most significant word first)
41304-41305	Minutes in Standby Total	RO	WORD * 2	minutes (most significant word first)
41306-41307	Minutes in Standby since Reset	RO	WORD * 2	minutes (most significant word first)

Register	Data Description	Access	Data Type	Range/Units
41308-41309	Minutes of Operation Total	RO	WORD * 2	minutes (most significant word first)
41310-41311	Minutes of Operation since Reset	RO	WORD * 2	minutes (most significant word first)
41312	Switch Transfers Total	RO	WORD	
41313	Switch Transfers since Reset	RO	WORD	
41314	Failures to Transfer Total	RO	WORD	
41315	Failures to Transfer since Reset	RO	WORD	
41316	Loss of Preferred Transfers Total	RO	WORD	
41317	Loss of Preferred Transfers since Reset	RO	WORD	
41318	Transfer Time N->E	RO	WORD	milliseconds
41319	Transfer Time E->N	RO	WORD	milliseconds
41320	Last Maintenance Date	RO	WORD [0:15]	0-4: Day of Month 5-8: Month of Year (Jan = 1, Feb = 2,... Dec = 12) 9-15: Year + 2000 (2001-2128)
41321	Proprietary	—	—	
41322	Proprietary	—	—	
41323-41330	Reserved for Future Use	—	—	
41350	Maintenance/Test and Manual Operations	WO	WORD [0:9]	0: Reset Maintenance Records
				1: Start Peak Shave
				2: End Peak Shave
				3: Start Remote Loaded Test
				4: Start Remote Unloaded Test
				5: Reserved for future use (always 0)
				6: End Remote Test
				7: Force Transfer to OFF
				8: Resume Program Trans. Operation
9: End Current Time Delay				
41351	Auto-Load Run Time	WO	WORD	Minutes (sending any non-zero value starts test)
41352	Clear Event Log	WO	WORD [0]	0: 1=Clear Log
41353	Reserved for future use	—	—	Return 0
42150-42249	Events 0 - 19	RO	WORD * 100	Time, Date, Code, Param1, Param2
42250-42349	Events 20 - 39	RO	WORD * 100	Time, Date, Code, Param1, Param2
42350-42449	Events 40 - 59	RO	WORD * 100	Time, Date, Code, Param1, Param2
42450-42549	Events 60 - 79	RO	WORD * 100	Time, Date, Code, Param1, Param2
42550-42649	Events 80 - 99	RO	WORD * 100	Time, Date, Code, Param1, Param2
42650-42749	Reserved for future use	—	—	Return 0 (all registers)
42750	Event Window Start Time	RW	WORD	Minutes since midnight
42751	Event Window Start Date	RW	WORD [0:15]	0-4: Day of Month 5-8: Month of Year (Jan = 1, Feb = 2,... Dec = 12) 9-15: Year + 2000 (2000-2128)
42752	Event Window End Time	RW	WORD	Minutes since midnight

Register	Data Description	Access	Data Type	Range/Units
42753	Event Window End Date	RW	WORD [0:15]	0-4: Day of Month
				5-8: Month of Year (Jan = 1, Feb = 2,... Dec = 12)
				9-15: Year + 2000 (2000-2128)
42754	Number of Events in Window	RO	WORD	
42755-42854	Windowed Events 0 - 19	RO	WORD* 100	Time, Date, Code, Param1, Param2
42900-42949	Reserved for Future Use	—	—	Return 0 (all registers)
43400	Calibrate L1L2 Normal Source Voltage	WO	WORD	Volts * 10
43401	Password for 43400	WO	WORD	0 - 32768
43402	Calibrate L2L3 Normal Source Voltage	WO	WORD	Volts * 10
43403	Password for 43402	WO	WORD	0 - 32768
43404	Calibrate L3L1 Normal Source Voltage	WO	WORD	Volts * 10
43405	Password for 43404	WO	WORD	0 - 32768
43406	Calibrate L1L2 Emergency Source Voltage	WO	WORD	Volts * 10
43407	Password for 43406	WO	WORD	0 - 32768
43408	Calibrate L2L3 Emergency Source Voltage	WO	WORD	Volts * 10
43409	Password for 43408	WO	WORD	0 - 32768
43410	Calibrate L3L1 Emergency Source Voltage	WO	WORD	Volts * 10
43411	Password for 43410	WO	WORD	0 - 32768
43412	Calibrate L1L0 Normal Source Voltage	WO	WORD	Volts * 10
43413	Password for 43412	WO	WORD	0 - 32768
43414	Calibrate L2L0 Normal Source Voltage	WO	WORD	Volts * 10
43415	Password for 43414	WO	WORD	0 - 32768
43416	Calibrate L3L0 Normal Source Voltage	WO	WORD	Volts * 10
43417	Password for 43416	WO	WORD	0 - 32768
43418	Calibrate L1L0 Emergency Source Voltage	WO	WORD	Volts * 10
43419	Password for 43418	WO	WORD	0 - 32768
43420	Calibrate L2L0 Emergency Source Voltage	WO	WORD	Volts * 10
43421	Password for 43420	WO	WORD	0 - 32768
43422	Calibrate L3L0 Emergency Source Voltage	WO	WORD	Volts * 10
43423	Password for 43422	WO	WORD	0 - 32768
43424	Calibrate L1 Current	WO	WORD	Amps * 10
43425	Password for 43424	WO	WORD	0 - 32768
43426	Calibrate L2 Current	WO	WORD	Amps * 10
43427	Password for 43426	WO	WORD	0 - 32768
43428	Calibrate L3 Current	WO	WORD	Amps * 10
43429	Password for 43428	WO	WORD	0 - 32768
43450	Key Press Status	RO	WORD [0:3]	One bit per button
43500	User Defined Value	RW	WORD	For internal use

Register	Data Description	Access	Data Type	Range/Units
43501	User Defined Value	RW	WORD	For internal use
43502	User Defined Value	RW	WORD	For internal use
43503	User Defined Value	RW	WORD	For internal use
43504	User Defined Value	RW	WORD	For internal use
43505	User Defined Value	RW	WORD	For internal use
43506	User Defined Value	RW	WORD	For internal use
43507	User Defined Value	RW	WORD	For internal use
43508	User Defined Value	RW	WORD	For internal use
43509	User Defined Value	RW	WORD	For internal use
43552-43599	Reserved for future use			Return 0 (all registers)
43700	Controller Parameter Force Save Status	RW	WORD	0: Idle 1: Force the parameters to be saved 2: Parameters have been saved successfully
43701	Password for register 43550	WO	WORD	0 - 32768 (factory password)
43800	Reserved for future use	RW	WORD	0 = None, 1 = Time Based, 2 = Current Based
43801	Load Control Mode	RW	WORD	0 = None, 1 = Time Based, 2 = Current Based
43802	Source 1 Add Load Amperage	RW	WORD	0-4000 Amps
43803	Source 1 Remove Load Amperage	RW	WORD	0-4000 Amps
43804	Source 2 Add Load Amperage	RW	WORD	0-4000 Amps
43805	Source 2 Remove Load Amperage	RW	WORD	0-4000 Amps
43806	Source 1 Current Based Load Control Output 1 Enable	RW	WORD	0 = Disabled; 1= Enabled
43807	Source 1 Current Based Load Control Output 2 Enable	RW	WORD	0 = Disabled; 1= Enabled
43808	Source 1 Current Based Load Control Output 3 Enable	RW	WORD	0 = Disabled; 1= Enabled
43809	Source 1 Current Based Load Control Output 4 Enable	RW	WORD	0 = Disabled; 1= Enabled
43810	Source 1 Current Based Load Control Output 5 Enable	RW	WORD	0 = Disabled; 1= Enabled
43811	Source 1 Current Based Load Control Output 6 Enable	RW	WORD	0 = Disabled; 1= Enabled
43812	Source 1 Current Based Load Control Output 7 Enable	RW	WORD	0 = Disabled; 1= Enabled
43813	Source 1 Current Based Load Control Output 8 Enable	RW	WORD	0 = Disabled; 1= Enabled
43814	Source 1 Current Based Load Control Output 9 Enable	RW	WORD	0 = Disabled; 1= Enabled
43815	Source 1 Current Based Load Control Output 1 Add Priority	RW	WORD	1-9
43816	Source 1 Current Based Load Control Output 2 Add Priority	RW	WORD	1-9
43817	Source 1 Current Based Load Control Output 3 Add Priority	RW	WORD	1-9
43818	Source 1 Current Based Load Control Output 4 Add Priority	RW	WORD	1-9
43819	Source 1 Current Based Load Control Output 5 Add Priority	RW	WORD	1-9
43820	Source 1 Current Based Load Control Output 6 Add Priority	RW	WORD	1-9
43821	Source 1 Current Based Load Control Output 7 Add Priority	RW	WORD	1-9
43822	Source 1 Current Based Load Control Output 8 Add Priority	RW	WORD	1-9
43823	Source 1 Current Based Load Control Output 9 Add Priority	RW	WORD	1-9

Register	Data Description	Access	Data Type	Range/Units
43824	Source 1 Current Based Load Control Output 1 Remove Priority	RW	WORD	1-9
43825	Source 1 Current Based Load Control Output 2 Remove Priority	RW	WORD	1-9
43826	Source 1 Current Based Load Control Output 3 Remove Priority	RW	WORD	1-9
43827	Source 1 Current Based Load Control Output 4 Remove Priority	RW	WORD	1-9
43828	Source 1 Current Based Load Control Output 5 Remove Priority	RW	WORD	1-9
43829	Source 1 Current Based Load Control Output 6 Remove Priority	RW	WORD	1-9
43830	Source 1 Current Based Load Control Output 7 Remove Priority	RW	WORD	1-9
43831	Source 1 Current Based Load Control Output 8 Remove Priority	RW	WORD	1-9
43832	Source 1 Current Based Load Control Output 9 Remove Priority	RW	WORD	1-9
43833	Source 1 Current Based Load Control Output 1 Add Time	RW	WORD	0-3600
43834	Source 1 Current Based Load Control Output 2 Add Time	RW	WORD	0-3600
43835	Source 1 Current Based Load Control Output 3 Add Time	RW	WORD	0-3600
43836	Source 1 Current Based Load Control Output 4 Add Time	RW	WORD	0-3600
43837	Source 1 Current Based Load Control Output 5 Add Time	RW	WORD	0-3600
43838	Source 1 Current Based Load Control Output 6 Add Time	RW	WORD	0-3600
43839	Source 1 Current Based Load Control Output 7 Add Time	RW	WORD	0-3600
43840	Source 1 Current Based Load Control Output 8 Add Time	RW	WORD	0-3600
43841	Source 1 Current Based Load Control Output 9 Add Time	RW	WORD	0-3600
43842	Source 1 Current Based Load Control Output 1 Remove Time	RW	WORD	0-3600
43843	Source 1 Current Based Load Control Output 2 Remove Time	RW	WORD	0-3600
43844	Source 1 Current Based Load Control Output 3 Remove Time	RW	WORD	0-3600
43845	Source 1 Current Based Load Control Output 4 Remove Time	RW	WORD	0-3600
43846	Source 1 Current Based Load Control Output 5 Remove Time	RW	WORD	0-3600
43847	Source 1 Current Based Load Control Output 6 Remove Time	RW	WORD	0-3600
43848	Source 1 Current Based Load Control Output 7 Remove Time	RW	WORD	0-3600
43849	Source 1 Current Based Load Control Output 8 Remove Time	RW	WORD	0-3600
43850	Source 1 Current Based Load Control Output 9 Remove Time	RW	WORD	0-3600
43851	Source 2 Current Based Load Control Output 1 Enable	RW	WORD	0 = Disabled; 1= Enabled
43852	Source 2 Current Based Load Control Output 2 Enable	RW	WORD	0 = Disabled; 1= Enabled
43853	Source 2 Current Based Load Control Output 3 Enable	RW	WORD	0 = Disabled; 1= Enabled

Register	Data Description	Access	Data Type	Range/Units
43854	Source 2 Current Based Load Control Output 4 Enable	RW	WORD	0 = Disabled; 1= Enabled
43855	Source 2 Current Based Load Control Output 5 Enable	RW	WORD	0 = Disabled; 1= Enabled
43856	Source 2 Current Based Load Control Output 6 Enable	RW	WORD	0 = Disabled; 1= Enabled
43857	Source 2 Current Based Load Control Output 7 Enable	RW	WORD	0 = Disabled; 1= Enabled
43858	Source 2 Current Based Load Control Output 8 Enable	RW	WORD	0 = Disabled; 1= Enabled
43859	Source 2 Current Based Load Control Output 9 Enable	RW	WORD	0 = Disabled; 1= Enabled
43860	Source 2 Current Based Load Control Output 1 Add Priority	RW	WORD	1-9
43861	Source 2 Current Based Load Control Output 2 Add Priority	RW	WORD	1-9
43862	Source 2 Current Based Load Control Output 3 Add Priority	RW	WORD	1-9
43863	Source 2 Current Based Load Control Output 4 Add Priority	RW	WORD	1-9
43864	Source 2 Current Based Load Control Output 5 Add Priority	RW	WORD	1-9
43865	Source 2 Current Based Load Control Output 6 Add Priority	RW	WORD	1-9
43866	Source 2 Current Based Load Control Output 7 Add Priority	RW	WORD	1-9
43867	Source 2 Current Based Load Control Output 8 Add Priority	RW	WORD	1-9
43868	Source 2 Current Based Load Control Output 9 Add Priority	RW	WORD	1-9
43869	Source 2 Current Based Load Control Output 1 Remove Priority	RW	WORD	1-9
43870	Source 2 Current Based Load Control Output 2 Remove Priority	RW	WORD	1-9
43871	Source 2 Current Based Load Control Output 3 Remove Priority	RW	WORD	1-9
43872	Source 2 Current Based Load Control Output 4 Remove Priority	RW	WORD	1-9
43873	Source 2 Current Based Load Control Output 5 Remove Priority	RW	WORD	1-9
43874	Source 2 Current Based Load Control Output 6 Remove Priority	RW	WORD	1-9
43875	Source 2 Current Based Load Control Output 7 Remove Priority	RW	WORD	1-9
43876	Source 2 Current Based Load Control Output 8 Remove Priority	RW	WORD	1-9
43877	Source 2 Current Based Load Control Output 9 Remove Priority	RW	WORD	1-9
43878	Source 2 Current Based Load Control Output 1 Add Time	RW	WORD	0-3600
43879	Source 2 Current Based Load Control Output 2 Add Time	RW	WORD	0-3600
43880	Source 2 Current Based Load Control Output 3 Add Time	RW	WORD	0-3600
43881	Source 2 Current Based Load Control Output 4 Add Time	RW	WORD	0-3600
43882	Source 2 Current Based Load Control Output 5 Add Time	RW	WORD	0-3600
43883	Source 2 Current Based Load Control Output 6 Add Time	RW	WORD	0-3600

Register	Data Description	Access	Data Type	Range/Units
43884	Source 2 Current Based Load Control Output 7 Add Time	RW	WORD	0-3600
43885	Source 2 Current Based Load Control Output 8 Add Time	RW	WORD	0-3600
43886	Source 2 Current Based Load Control Output 9 Add Time	RW	WORD	0-3600
43887	Source 2 Current Based Load Control Output 1 Remove Time	RW	WORD	0-3600
43888	Source 2 Current Based Load Control Output 2 Remove Time	RW	WORD	0-3600
43889	Source 2 Current Based Load Control Output 3 Remove Time	RW	WORD	0-3600
43890	Source 2 Current Based Load Control Output 4 Remove Time	RW	WORD	0-3600
43891	Source 2 Current Based Load Control Output 5 Remove Time	RW	WORD	0-3600
43892	Source 2 Current Based Load Control Output 6 Remove Time	RW	WORD	0-3600
43893	Source 2 Current Based Load Control Output 7 Remove Time	RW	WORD	0-3600
43894	Source 2 Current Based Load Control Output 8 Remove Time	RW	WORD	0-3600
43895	Source 2 Current Based Load Control Output 9 Remove Time	RW	WORD	0-3600
43920	Prime Power Event Source 1 Duration	RW	WORD	(Hours * 0.1)
43921	Prime Power Event Source 2 Duration	RW	WORD	(Hours * 0.1)
43922	Prime Power Event Source 1 Count Down	RO	WORD*2	Minutes
43924	Prime Power Event Source 2 Count Down	RO	WORD*2	Minutes
43926	Prime Power Event Start/Stop	RW	WORD	0 = Stop, 1 = Start
43930	USB Data Logging Period	RW	WORD	0 = Seconds; 1 = Minutes, 2 = Hours; 3 = Days
43940	Min/Max Logging Period	RW	WORD	0 = Continuous; 1 = Calendar; 2 = Daily; 3 = Weekly
43941	Min/Max Logging Calendar Start Date (day)	RW	WORD [0:15]	0-4: Day of Month
	Min/Max Logging Calendar Start Date (month)			5-8: Month of Year (Jan = 1, Feb = 2, Dec = 12)
	Min/Max Logging Calendar Start Date (year)			9-15: Year + 2000 (2001-2128)
43942	Min/Max Logging Start Time	RW	WORD	Minutes
43943	Min/Max Logging Calendar Stop Date (day)	RW	WORD [0:15]	0-4: Day of Month
	Min/Max Logging Calendar Stop Date (month)			5-8: Month of Year (Jan = 1, Feb = 2, Dec = 12)
	Min/Max Logging Calendar Stop Date (year)			9-15: Year + 2000 (2001-2128)
43944	Min/Max Logging Stop Time	RW	WORD	Minutes
43945	Min/Max Logging Days	RW	WORD	Number of days in period
43946	Min/Max Logging Weeks	RW	WORD	Number of weeks in period
49999	Device ID	RO	WORD	MPAC™ 1500 ATS Controller = 0x17

10.4.4 Event Codes

Event codes are used in the following registers:

- Programmable inputs and outputs, registers 40108–40153
- Common event alarms, registers 40800–40864
- Event log registers 42150–42649

Code	Description
1	End Time Delay Button
2	Test Button
3	Exercise Button
4	Lamp Test Button
5	Service Required Reset
6	Maintenance DIP Switch Changed State
7	Password DIP Switch Changed State
8	Spare DIP Switch Changed State
9	Spare DIP Switch Changed State
10	Supervised Transfer Switch Changed State
11–26	Reserved
27	New I/O Module Detected
28–32	Reserved
33	No Output Function Defined
34	Preferred Source Available
35	Standby Source Available
36	Contactor in Preferred Position
37	Contactor in Standby Position
38	Contactor in Off Position
39	Contactor in Source N Position
40	Contactor in Source E Position
41	Not in Auto
42	Load Control Active
43	Low Battery on Standby Source
44	Exerciser Started
45	Test Mode Active
46	Peak Shave Active
47	Non-Emergency Transfer
48	Back-up Battery Low
49	Maintenance Mode Active
50	Load Bank Activate
51	Start Source N Generator
52	Start Source E Generator
53	In Phase Monitor Waiting for Synch
54	Common Alarm
55	Source N Under Voltage
56	Source N Over Voltage
57	Source N Voltage Unbalanced
58	Source N Loss of Phase
59	Source N Phase Rotation Error
60	Source N Over Frequency
61	Source N Under Frequency

Code	Description
62	Source E Under Voltage
63	Source E Over Voltage
64	Source E Voltage Unbalanced
65	Source E Loss of Phase
66	Source E Phase Rotation Error
67	Source E Over Frequency
68	Source E Under Frequency
69	Failure to Acquire Standby
70	Failure to Acquire Preferred
71	Failure to Transfer
72	I/O Module Comms Lost
73	Audible Alarm Status
74	Aux. Switch Fault
75	Aux. Switch Open
76	Load Control Output #0
77	Load Control Output #1
78	Load Control Output #2
79	Load Control Output #3
80	Load Control Output #4
81	Load Control Output #5
82	Load Control Output #6
83	Load Control Output #7
84	Load Control Output #8
85	Modbus Controlled RDO #1
86	Modbus Controlled RDO #2
87	Modbus Controlled RDO #3
88	Modbus Controlled RDO #4
89	3 Source System Disable Output
90	Common Alarm 2
91	Audible Alarm Has Been Silenced
92–98	Reserved for future use
99	No Input Function Defined
100	Forced Transfer to Off
101	Peak Shave Mode
102	Inhibit Transfer
103	Remote End Time Delay
104	Remote Test
105	Low Battery Voltage
106	Remote Common Alarm
107	Bypass Contactor Disable
108	3 Source System Disable Input
109	Remote Monitor Input #1
110	Remote Monitor Input #2
111	Remote Monitor Input #3
112	Remote Monitor Input #4
113–119	Reserved for future use
120	System Ready
121	Critical Service Required

Code	Description
122	Non--Critical Service Required
123	System Parameter Changed
124	Source N Available
125	Source E Available
126	Over Frequency
127	Under Frequency
128	Loss of Phase
129	Phase Rotation Error
130	Over Voltage L1--L2
131	Over Voltage L2--L3
132	Over Voltage L3--L1
133	Under Voltage L1--L2
134	Under Voltage L2--L3
135	Under Voltage L3--L1
136	Voltage Unbalanced
137	History Log Saved
138-147	Reserved
148	Inphase Synching
149-174	Reserved for future use
175	Auto Loaded Test Complete
176-200	Reserved for future use
201	Transfer Mode Changed
202	Default History Loaded
203	Reserved for future use
204	Default Settings Loaded
205	MLB Programmable Input Changed
206	MLB Programmable Output Changed
207	Exercise Loaded Changed
208	Test Loaded Changed
209	One/Two Week Exercise Changed
210	Disable Exercise Changed
211	Preferred Source Changed
212	Default Settings Loaded
213-214	Reserved for future use
215	Backup Parameter File Loaded
216	Backup History File Loaded
217-222	Reserved for future use
223	Modbus Force Transfer to Off
224	Modbus Peak Shave
225	Modbus System Test
226-247	Reserved for future use
248	Battery Backup Output Changed
249-250	Reserved for future use
251	A USB Device Has Been Connected
252	A USB Device Has Been Disconnected
256	System Ready

11.1 Introduction

The Power Monitor uses KBUS protocol for communication. The Modbus®/KBUS converter kit is required for Modbus communication with these devices. See Figure 11-2.

Installing the Modbus®/KBUS converter kit allows this controller to communicate with a personal computer running Monitor III software. For other Modbus applications, the Modbus master must be programmed to read the Modbus registers shown in this manual. A system designer trained in the application of Modbus® protocol must write and thoroughly test the program before implementation.

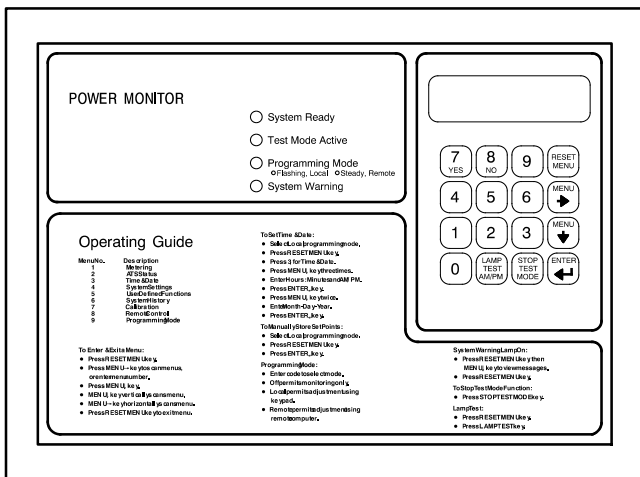

Figure 11-1 Power Monitor PM340

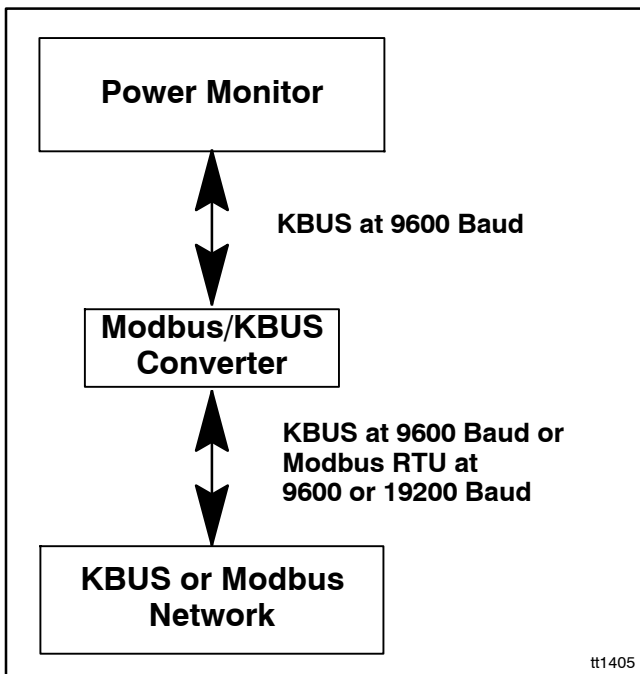
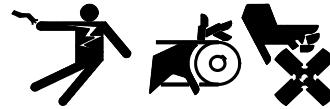

Figure 11-2 Modbus/KBUS Converter Function

11.2 Hardware and Connections

⚠ WARNING



Accidental starting.
Can cause severe injury or death.

Disconnect the battery cables before working on the generator set. Remove the negative (-) lead first when disconnecting the battery. Reconnect the negative (-) lead last when reconnecting the battery.

Disabling the generator set. Accidental starting can cause severe injury or death. Before working on the generator set or connected equipment, disable the generator set as follows: (1) Move the generator set master switch to the OFF position. (2) Disconnect the power to the battery charger. (3) Remove the battery cables, negative (-) lead first. Reconnect the negative (-) lead last when reconnecting the battery. Follow these precautions to prevent starting of the generator set by an automatic transfer switch, remote start/stop switch, or engine start command from a remote computer.

The Modbus/KBUS converter kit GM41143-KP3 replaces RS-232 and RS-485 communication modules and allows the selection of either KBUS or Modbus communication. See Figure 11-3 for the converter location inside the controller.

If your device is equipped with an RS-232/RS-485 communication module, remove the old communication module and ribbon cable before installing the new Modbus/KBUS converter and ribbon cable.

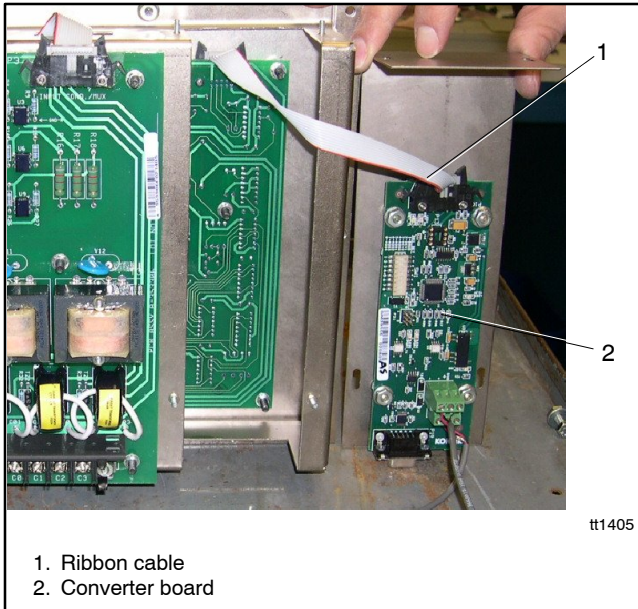

1. Ribbon cable
2. Converter board

Figure 11-3 Converter Module Location for Power Monitor

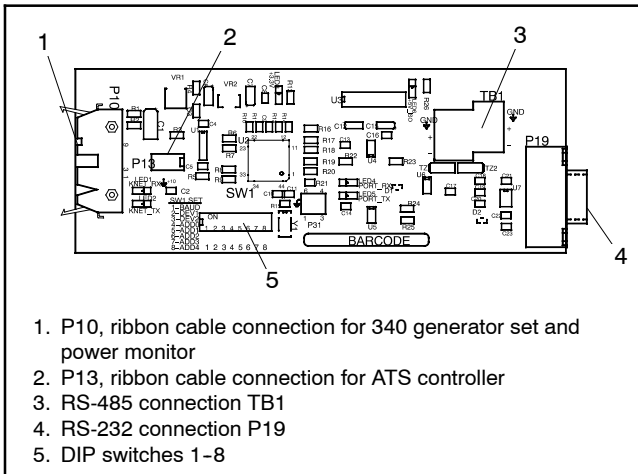

1. P10, ribbon cable connection for 340 generator set and power monitor
2. P13, ribbon cable connection for ATS controller
3. RS-485 connection TB1
4. RS-232 connection P19
5. DIP switches 1-8

Figure 11-4 Modbus/KBUS Converter Board

Device	Menu or Index	Parameter	Setting
Power monitor	Menu 8, Remote Control	On Line	YES
		Local, LAN, Remote, or Remote Area Network	Select the appropriate setting for your connection type. Use Local for Ethernet connections. See TT-1405 for more information.
		Address	Any *
		Baud rate	9600 †
<p>* The network address is set using DIP switches on the converter module and will override the network address on the controller. † This baud rate must be set at 9600 to match the KBUS side of the Modbus/KBUS converter. It may be different from the Modbus baud rates of other devices in the system.</p>			

Figure 11-5 Controller Settings for Modbus Communication

Figure 11-4 shows the Modbus/KBUS converter circuit board connections and DIP switches. Refer to Installation Instructions TT-1405, provided with the converter kit, for converter installation and connection instructions. Set the converter DIP switches for baud rate, device type, and network address as described in TT-1405.

11.3 Device Setup

Configure power monitor for remote communications by setting the parameters shown in Figure 11-5. See TT-1405 and the controller operation manual for more information.

11.4 Power Monitor Modbus Registers

Refer to Section 1.3 for definitions of terms and symbols used in the register tables.

Register	Data Description	Access	Data Type	Range/Units
40001				
40002	System Time	RO	WORD	
40003	Day of Week	RO	WORD	
40004	Month	RO	WORD	1-12
40005	Day	RO	WORD	1-31
40006	Year	RO	WORD	
40007	Week of Month	RO	WORD	
40008	Voltage L1-L2	RO	WORD	volts
40009	Voltage L2-L3	RO	WORD	volts
40010	Voltage L3-L1	RO	WORD	volts
40011	Frequency	RO	WORD	Hz * 10
40012	Voltage L1-L0	RO	WORD	volts
40013	Voltage L2-L0	RO	WORD	volts
40014	Voltage L3-L0	RO	WORD	volts
40015	Alert Code	RO	WORD	Alert Code
40016	Analog Input #1 Percentage	RO	WORD	% * 10
40017	Analog Input #2 Percentage	RO	WORD	% * 10
40019	Power Supply Voltage	RO	WORD	VDC * 10
40020	L1 Current	RO	WORD	amps
40021	L2 Current	RO	WORD	amps
40022	L3 Current	RO	WORD	amps
40023	Power Factor	RO	WORD	* 100
40024	Total Real Power	RO	WORD	kW
40025	Total Imaginary Power	RO	WORD	kVAR
40026	PF Lead/Lag	RO	WORD[0]	0: 0 = leading; 1 = lagging
40030	System Status	RO	WORD[0:7]	0-1: Switch Position (00=off; 01=Normal; 10=Emerg; 11=Undefined)
				2-3: Contactor Position (00=off; 01=Normal; 10=Emerg; 11=Undefined)
				4-5: Program Mode (00=off; 01=Remote; 10=Local; 11=Undefined)
40030, cont.	System Status	RO	WORD[0:7]	6: Test Mode Timed
				7: Test Mode Active
				8-15: Unused
40040	Aux 1 Delay Time	RO	WORD	sec.
40041	Aux 2 Delay Time	RO	WORD	sec.
40042	Aux 3 Delay Time	RO	WORD	sec.
40043	Aux 4 Delay Time	RO	WORD	sec.
40044	Aux 5 Delay Time	RO	WORD	sec.
40045	Aux 6 Delay Time	RO	WORD	sec.
40046	System Voltage	RO	WORD	volts, 105-14600
40047	System Frequency	RO	WORD	Hz, 48-62
40048	ATS Rating	RO	WORD	A, 0-3000
40049	Connection	RO	WORD[0:1]	0: 0=wye; 1=delta
				1: 0=single phase; 1=three phase
40056-40057	Time in Normal	RO	WORD*2	hours * 10
40058-40059	Time in Off	RO	WORD*2	hours * 10
40060-40061	Time in Emergency	RO	WORD*2	hours * 10
40062	Shutdown #1 Code	RO	WORD	code

Register	Data Description	Access	Data Type	Range/Units
40063	Shutdown #1 Month	RO	WORD	1-12
40064	Shutdown #1 Day	RO	WORD	1-31
40065	Shutdown #1 Year	RO	WORD	
40066	Shutdown #2 Code	RO	WORD	code
40067	Shutdown #2 Month	RO	WORD	1-12
40068	Shutdown #2 Day	RO	WORD	1-31
40069	Shutdown #2 Year	RO	WORD	
40070	Shutdown #3 Code	RO	WORD	code
40071	Shutdown #3 Month	RO	WORD	1-12
40072	Shutdown #3 Day	RO	WORD	1-31
40073	Shutdown #3 Year	RO	WORD	
40074	Shutdown #4 Code	RO	WORD	code
40075	Shutdown #4 Month	RO	WORD	1-12
40076	Shutdown #4 Day	RO	WORD	1-31
40077	Shutdown #4 Year	RO	WORD	
40095-40099	Designation	RO	WORD*5	9 chars, 1 per byte, first char = LSB, last byte ignored
40100-40109	Load Description	RO	WORD*10	20 chars, 1 per byte, first char = LSB
40110-40119	Location	RO	WORD*10	20 chars, 1 per byte, first char = LSB
40120-40132	Model No.	RO	WORD*13	26 chars, 1 per byte, first char = LSB
40133-40140	Spec. No.	RO	WORD*8	16 chars, 1 per byte, first char = LSB
40141-40143	Serial No.	RO	WORD*3	6 chars, 1 per byte, first char = LSB
40144-40146	Controller Serial No.	RO	WORD*3	6 chars, 1 per byte, first char = LSB
40147-40156	Analog Input #1 Description	RO	WORD*10	20 chars, 1 per byte, first char = LSB
40157-40166	Analog Input #2 Description	RO	WORD*10	20 chars, 1 per byte, first char = LSB
40167-40176	Auxiliary 1 Description	RO	WORD*10	20 chars, 1 per byte, first char = LSB
40177-40186	Auxiliary 2 Description	RO	WORD*10	20 chars, 1 per byte, first char = LSB
40187-40196	Auxiliary 3 Description	RO	WORD*10	20 chars, 1 per byte, first char = LSB
40197-40206	Auxiliary 4 Description	RO	WORD*10	20 chars, 1 per byte, first char = LSB
40207-40216	Auxiliary 5 Description	RO	WORD*10	20 chars, 1 per byte, first char = LSB
40217-40226	Auxiliary 6 Description	RO	WORD*10	20 chars, 1 per byte, first char = LSB
40300	Timed Run Time	RW	WORD	minutes

11.5 Alert Codes

Alert Code	Description
0	Auxiliary 1
1	Auxiliary 2
2	Auxiliary 3
3	Auxiliary 4
4	Auxiliary 5
5	Auxiliary 6
6	Test Mode Active
7	Internal Error
8	System Ready
9	Power Down Error

Appendix A Abbreviations

The following list contains abbreviations that may appear in this publication.

A, amp	ampere	cfm	cubic feet per minute	est.	estimated
ABDC	after bottom dead center	CG	center of gravity	E-Stop	emergency stop
AC	alternating current	CID	cubic inch displacement	etc.	et cetera (and so forth)
A/D	analog to digital	CL	centerline	exh.	exhaust
ADC	advanced digital control; analog to digital converter	cm	centimeter	ext.	external
adj.	adjust, adjustment	CMOS	complementary metal oxide substrate (semiconductor)	F	Fahrenheit, female
ADV	advertising dimensional drawing	cogen.	cogeneration	fglass.	fiberglass
Ah	amp-hour	com	communications (port)	FHM	flat head machine (screw)
AHWT	anticipatory high water temperature	coml	commercial	fl. oz.	fluid ounce
AISI	American Iron and Steel Institute	Coml/Rec	Commercial/Recreational	flex.	flexible
ALOP	anticipatory low oil pressure	conn.	connection	freq.	frequency
alt.	alternator	cont.	continued	FS	full scale
Al	aluminum	CPVC	chlorinated polyvinyl chloride	ft.	foot, feet
ANSI	American National Standards Institute (formerly American Standards Association, ASA)	crit.	critical	ft. lb.	foot pounds (torque)
AO	anticipatory only	CRT	cathode ray tube	ft./min.	feet per minute
APDC	Air Pollution Control District	CSA	Canadian Standards Association	ftp	file transfer protocol
API	American Petroleum Institute	CT	current transformer	g	gram
approx.	approximate, approximately	Cu	copper	ga.	gauge (meters, wire size)
AQMD	Air Quality Management District	cUL	Canadian Underwriter's Laboratories	gal.	gallon
AR	as required, as requested	CUL	Canadian Underwriter's Laboratories	gen.	generator
AS	as supplied, as stated, as suggested	cu. in.	cubic inch	genset	generator set
ASE	American Society of Engineers	cw.	clockwise	GFI	ground fault interrupter
ASME	American Society of Mechanical Engineers	CWC	city water-cooled	GND, ⊕	ground
assy.	assembly	cyl.	cylinder	gov.	governor
ASTM	American Society for Testing Materials	D/A	digital to analog	gph	gallons per hour
ATDC	after top dead center	DAC	digital to analog converter	gpm	gallons per minute
ATS	automatic transfer switch	dB	decibel	gr.	grade, gross
auto.	automatic	dB(A)	decibel (A weighted)	GRD	equipment ground
aux.	auxiliary	DC	direct current	gr. wt.	gross weight
avg.	average	DCR	direct current resistance	H x W x D	height by width by depth
AVR	automatic voltage regulator	deg., °	degree	HC	hex cap
AWG	American Wire Gauge	dept.	department	HCHT	high cylinder head temperature
AWM	appliance wiring material	DFMEA	Design Failure Mode and Effects Analysis	HD	heavy duty
bat.	battery	dia.	diameter	HET	high exhaust temp., high engine temp.
BBDC	before bottom dead center	DI/EO	dual inlet/end outlet	hex	hexagon
BC	battery charger, battery charging	DIN	Deutsches Institut fur Normung e. V. (also Deutsche Industrie Normenausschuss)	Hg	mercury (element)
BCA	battery charging alternator	DIP	dual inline package	HH	hex head
BCI	Battery Council International	DPDT	double-pole, double-throw	HHC	hex head cap
BDC	before dead center	DS	disconnect switch	HP	horsepower
BHP	brake horsepower	DVR	digital voltage regulator	hr.	hour
blk.	black (paint color), block (engine)	E, emer.	emergency (power source)	HS	heat shrink
blk. htr.	block heater	ECM	electronic control module, engine control module	hsg.	housing
BMEP	brake mean effective pressure	EDI	electronic data interchange	HVAC	heating, ventilation, and air conditioning
bps	bits per second	EFR	emergency frequency relay	HWT	high water temperature
br.	brass	e.g.	for example (<i>exempli gratia</i>)	Hz	hertz (cycles per second)
BTDC	before top dead center	EG	electronic governor	IC	integrated circuit
Btu	British thermal unit	EGSA	Electrical Generating Systems Association	ID	inside diameter, identification
Btu/min.	British thermal units per minute	EIA	Electronic Industries Association	IEC	International Electrotechnical Commission
C	Celsius, centigrade	EI/EO	end inlet/end outlet	IEEE	Institute of Electrical and Electronics Engineers
cal.	calorie	EMI	electromagnetic interference	IMS	improved motor starting
CAN	controller area network	emiss.	emission	in.	inch
CARB	California Air Resources Board	eng.	engine	in. H ₂ O	inches of water
CB	circuit breaker	EPA	Environmental Protection Agency	in. Hg	inches of mercury
cc	cubic centimeter	ES	engineering special, engineered special	in. lb.	inch pounds
CCA	cold cranking amps	ESD	electrostatic discharge	Inc.	incorporated
ccw.	counterclockwise			ind.	industrial
CEC	Canadian Electrical Code			int.	internal
cert.	certificate, certification, certified			int./ext.	internal/external
cfh	cubic feet per hour			I/O	input/output
				IP	iron pipe
				ISO	International Organization for Standardization
				J	joule
				JIS	Japanese Industry Standard

k	kilo (1000)	MTBO	mean time between overhauls	rms	root mean square
K	kelvin	mtg.	mounting	rnd.	round
kA	kiloampere	MTU	Motoren-und Turbinen-Union	ROM	read only memory
KB	kilobyte (2 ¹⁰ bytes)	MW	megawatt	rot.	rotate, rotating
KBus	Kohler communication protocol	mW	milliwatt	rpm	revolutions per minute
kg	kilogram	μF	microfarad	RS	right side
kg/cm ²	kilograms per square centimeter	N, norm.	normal (power source)	RTU	remote terminal unit
kgm	kilogram-meter	NA	not available, not applicable	RTV	room temperature vulcanization
kg/m ³	kilograms per cubic meter	nat. gas	natural gas	RW	read/write
kHz	kilohertz	NBS	National Bureau of Standards	SAE	Society of Automotive Engineers
kJ	kilojoule	NC	normally closed	scfm	standard cubic feet per minute
km	kilometer	NEC	National Electrical Code	SCR	silicon controlled rectifier
kOhm, kΩ	kilo-ohm	NEMA	National Electrical Manufacturers Association	s, sec.	second
kPa	kilopascal	NFPA	National Fire Protection Association	SI	<i>Systeme internationale d'unites</i> , International System of Units
kph	kilometers per hour	Nm	newton meter	SI/EO	side in/end out
kV	kilovolt	NO	normally open	sil.	silencer
kVA	kilovolt ampere	no., nos.	number, numbers	SN	serial number
KVAR	kilovolt ampere reactive	NPS	National Pipe, Straight	SNMP	simple network management protocol
kW	kilowatt	NPSC	National Pipe, Straight-coupling	SPDT	single-pole, double-throw
kWh	kilowatt-hour	NPT	National Standard taper pipe thread per general use	SPST	single-pole, single-throw
kWm	kilowatt mechanical	NPTF	National Pipe, Taper-Fine	spec	specification
kWth	kilowatt-thermal	NR	not required, normal relay	specs	specification(s)
L	liter	ns	nanosecond	sq.	square
LAN	local area network	OC	overcrank	sq. cm	square centimeter
L x W x H	length by width by height	OD	outside diameter	sq. in.	square inch
lb.	pound, pounds	OEM	original equipment manufacturer	SS	stainless steel
lbm/ft ³	pounds mass per cubic feet	OF	overfrequency	std.	standard
LCB	line circuit breaker	opt.	option, optional	stl.	steel
LCD	liquid crystal display	OS	oversize, overspeed	tach.	tachometer
ld. shd.	load shed	OSHA	Occupational Safety and Health Administration	TD	time delay
LED	light emitting diode	OV	overvoltage	TDC	top dead center
Lph	liters per hour	oz.	ounce	TDEC	time delay engine cooldown
Lpm	liters per minute	p., pp.	page, pages	TDEN	time delay emergency to normal
LOP	low oil pressure	PC	personal computer	TDES	time delay engine start
LP	liquefied petroleum	PCB	printed circuit board	TDNE	time delay normal to emergency
LPG	liquefied petroleum gas	pF	picofarad	TDOE	time delay off to emergency
LS	left side	PF	power factor	TDON	time delay off to normal
L _{wa}	sound power level, A weighted	ph., ∅	phase	temp.	temperature
LWL	low water level	PHC	Phillips® head Crimptite® (screw)	term.	terminal
LWT	low water temperature	PHH	Phillips® hex head (screw)	THD	total harmonic distortion
m	meter, milli (1/1000)	PHM	pan head machine (screw)	TIF	telephone influence factor
M	mega (10 ⁶ when used with SI units), male	PLC	programmable logic control	TIR	total indicator reading
m ³	cubic meter	PMG	permanent magnet generator	tol.	tolerance
m ³ /hr.	cubic meters per hour	pot	potentiometer, potential	turbo.	turbocharger
m ³ /min.	cubic meters per minute	ppm	parts per million	typ.	typical (same in multiple locations)
mA	milliampere	PROM	programmable read-only memory	UF	underfrequency
man.	manual	psi	pounds per square inch	UHF	ultrahigh frequency
max.	maximum	psig	pounds per square inch gauge	UL	Underwriter's Laboratories, Inc.
MB	megabyte (2 ²⁰ bytes)	pt.	pint	UNC	unified coarse thread (was NC)
MCCB	molded-case circuit breaker	PTC	positive temperature coefficient	UNF	unified fine thread (was NF)
MCM	one thousand circular mils	PTO	power takeoff	univ.	universal
meggar	megohmmeter	PVC	polyvinyl chloride	US	undersize, underspeed
MHz	megahertz	qt.	quart, quarts	UV	ultraviolet, undervoltage
mi.	mile	qty.	quantity	V	volt
mil	one one-thousandth of an inch	R	replacement (emergency) power source	VAC	volts alternating current
min.	minimum, minute	rad.	radiator, radius	VAR	voltampere reactive
misc.	miscellaneous	RAM	random access memory	VDC	volts direct current
MJ	megajoule	RDO	relay driver output	VFD	vacuum fluorescent display
mJ	millijoule	ref.	reference	VGA	video graphics adapter
mm	millimeter	rem.	remote	VHF	very high frequency
mOhm, mΩ	milliohm	Res/Coml	Residential/Commercial	W	watt
MOhm, MΩ	megohm	RFI	radio frequency interference	WCR	withstand and closing rating
MOV	metal oxide varistor	RH	round head	w/	with
MPa	megapascal	RHM	round head machine (screw)	w/o	without
mpg	miles per gallon	rly.	relay	wt.	weight
mph	miles per hour			xfrm	transformer
MS	military standard				
ms	millisecond				
m/sec.	meters per second				
MTBF	mean time between failure				

Appendix B Noise and Wiring Practices

Electrical noise is an unwanted electrical signal that can cause errors in measurement, loss of control, malfunctions in microprocessor-based control systems, errors in data transfer between systems over communication links, or reductions in system performance.

Good system design and wiring practices can minimize noise levels and the effects of noise.

Noise, because of its random nature, is typically characterized by frequency distribution. Many noise sources are broad-spectrum, that is, they produce many frequencies distributed over a wide range. Broad-spectrum noise is particularly troublesome because it cannot be removed easily by filtering, and because it can affect a variety of systems in unpredictable ways. One common source of broad-spectrum noise is a switch, which can produce voltage and current changes when an electrical circuit is connected and disconnected.

Coupling is the transfer of signals between separate circuits. Signals from one circuit become noise in another. The amount of coupling is cumulative and is a function of the proximity of the circuits, their orientation, exposed area, and length of run. Minimize coupling by the following:

- Isolating circuits from each other by using separate raceways or conduit
- Separating circuits from each other by locating them as far apart as possible
- Enclosing circuits with a grounded metallic shield such as an enclosure, metallic conduit, or cable shield
- Running conductors perpendicular, rather than parallel, to each other
- Running wires loosely and randomly rather than bundling them tightly together
- Twisting a circuit's wires together in pairs

In an industrial environment, there are typically five types of circuits with different noise emission and rejection capabilities. The five types of circuits are as follows:

- **High-Power Distribution.** Circuits to high-power loads such as large electric motors and heaters can emit transient high levels of broad-spectrum noise. Loads on high-power distribution circuits are nearly immune to noise.

- **General Purpose Power Distribution.** Circuits to medium-power loads such as lighting, offices, light-duty equipment, and small motors such as fans and pumps can emit transient, medium levels of broad-spectrum noise. Some electronic equipment, such as computers, emits constant levels of broad-spectrum noise in addition to transient broad-spectrum noise. Loads on general-purpose circuits, except for sensitive electronic equipment, are nearly immune to noise.
- **Control.** Control circuits include DC circuits and 120 VAC maximum AC circuits that operate at a low power level (less than 1 W). Typical circuits include circuits to switches, actuators, and dry-contact relays, including the generator engine-start circuit. Control circuits emit transient low levels of broad-spectrum noise and are fairly immune to noise.
- **Analog.** Analog circuits are low-voltage DC circuits that convey measurement information as relatively small changes in current or voltage. Typical circuits include those connected to the controller's analog inputs. Analog circuits create the lowest noise levels and are the most sensitive to noise.
- **Communication and Signaling.** Communication and signaling circuits are low-voltage circuits that convey information. Typical circuits include RS-232 and RS-485 serial communication lines, telephone lines, and computer network lines. These circuits create noise with frequencies related to the communication signaling rate. These circuits have some level of built-in noise immunity. Typical systems will detect or correct errors caused by noise below certain levels, but with a corresponding reduction in the data transfer rate.

When planning an installation, separate all of these types of circuits as much as possible to minimize the hazards of insulation failure, accidental miswiring, and noise coupling. For best results, install control circuits, analog circuits, and communication and signaling circuits separately. Combining circuit types is unavoidable in the controller's enclosure and some other areas.

Note: It is very important to isolate high- and medium-power circuits in raceways or conduit separate from the other types of circuits.

Appendix C Decison-Maker 550 Controllers, Versions Below 2.10

This section contains Modbus® registers for Decision-Maker®550 controller with application code versions numbered below 2.10 (for example, code version number 1.34). See Section 4.4 for instructions to determine the application code version number for your controller.

Guide to Register Map

Description	Registers
Monitoring	40001-40083
Electrical Output	40001-40027
Reserved	40028-40032
Engine Status	40033-40054
Reserved	40055-40060
Analog Input Status	40061-40068
Reserved	40069-40076
Digital Input status	40077-40078
Reserved	40079-40083
Maintenance	40084-40112
Time/Date	40113-40115
Time Delay Settings	40116-40124
Settings and Setpoints	40125-40146
Factory Setup	40147-40226
Digital Input Setup	40227-40499
Analog Input Setup	40500-40739
Remapped Registers *	40740-40837
Relay Driver Output Status	40838-40839
Relay Driver Output Setup	40840-40870
Event History	40871-41270
Miscellaneous Strings	41271-41295
Reserved and Write-Only Registers	41296-41308

Modbus Registers

Register	Parameter	Access	Data Type	Range/Units
40001	L1 - L2 Voltage	RO	WORD	Volts AC
40002	L2 - L3 Voltage	RO	WORD	Volts AC
40003	L3 - L1 Voltage	RO	WORD	Volts AC
40004	L1 - L0 Voltage	RO	WORD	Volts AC
40005	L2 - L0 Voltage	RO	WORD	Volts AC
40006	L3 - L0 Voltage	RO	WORD	Volts AC
40007	L1 Current	RO	WORD	Amps AC
40008	L2 Current	RO	WORD	Amps AC
40009	L3 Current	RO	WORD	Amps AC
40010	Frequency	RO	WORD	Hz x 100
40011	Total kW	RO	WORD	kW
40012	Percent Of Rated kW	RO	WORD	% Rated kW
40013	Total Power Factor	RO	SWORD	PF x 100
40014	L1 kW	RO	WORD	kW
40015	L1 Power Factor	RO	SWORD	PF x 100
40016	L2 kW	RO	WORD	kW
40017	L2 Power Factor	RO	SWORD	PF x 100
40018	L3 kW	RO	WORD	kW
40019	L3 Power Factor	RO	SWORD	PF x 100
40020	Total kVAR	RO	SWORD	kVAR
40021	L1 kVAR	RO	SWORD	kVAR
40022	L2 kVAR	RO	SWORD	kVAR
40023	L3 kVAR	RO	SWORD	kVAR
40024	Total kVA	RO	WORD	kVA
40025	L1 kVA	RO	WORD	kVA
40026	L2 kVA	RO	WORD	kVA
40027	L3 kVA	RO	WORD	kVA
40028	<i>Reserved for Future Use</i>	RO	WORD	
40029	<i>Reserved for Future Use</i>	RO	WORD	
40030	<i>Reserved for Future Use</i>	RO	WORD	
40031	<i>Reserved for Future Use</i>	RO	WORD	
40032	<i>Reserved for Future Use</i>	RO	WORD	
40033	Oil Pressure*	RO	WORD	kPa/psi
40034	Coolant Temperature*	RO	SWORD	°C/°F
40035	Engine Speed*	RO	WORD	rpm
40036	Local Battery Voltage*	RO	WORD	Volts DC x 10
40037	Fuel Pressure*	RO	WORD	kPa/psi (ECM only)
40038	Fuel Temperature*	RO	SWORD	°C/°F (ECM only)
40039	Fuel Rate*	RO	WORD	Liters/Hour x 100/Gallons/Hour x 100 (ECM only)
40040	Used Last Run*	RO	WORD	Liters/Gallons (ECM only)
40041	Coolant Pressure*	RO	WORD	kPa/psi (ECM only)
40042	Coolant Level*	RO	WORD	% x 10 (ECM only)
40043	Oil Temperature*	RO	SWORD	°C/°F (ECM only)
40044	Oil Level*	RO	WORD	% x 10 (ECM only)
40045	Crankcase Pressure*	RO	WORD	kPa/psi (ECM only)
40046	Ambient Temperature*	RO	SWORD	°C/°F (ECM only)
40047	ECM Battery Voltage*	RO	WORD	Volts DC x 10 (ECM only)
40048	ECM Status	RO	WORD	0 = ECM-Equipped, 1 = Non-ECM
40049	<i>Reserved for Future Use</i>	RO	WORD	
40050	<i>Reserved for Future Use</i>	RO	WORD	

*0x7FD6 = data unavailable. 0x7FFF = data is out of range.

Register	Parameter	Access	Data Type	Range/Units
40051	<i>Reserved for Future Use</i>	RO	WORD	
40052	<i>Reserved for Future Use</i>	RO	WORD	
40053	<i>Reserved for Future Use</i>	RO	WORD	
40054	System Event Stack	RO	7 WORDS	Word #1: System Events 0-15 Word #2: System Events 16-31 Word #3: System Events 32-47 Word #4: System Events 48-63 Word #5: System Events 64-79 Word #6: System Events 80-95 Word #7: System Events 96-99 (bits 4-15 unused) Event exists if individual bit is set. Refer to Message Codes Section in this Appendix for message codes and descriptions.
40061	Analog Input 00(Battery voltage)*	RO	WORD	Volts DC
40062	Analog Input 01*	RO	WORD	User-Defined
40063	Analog Input 02*	RO	WORD	User-Defined
40064	Analog Input 03*	RO	WORD	User-Defined
40065	Analog Input 04*	RO	WORD	User-Defined
40066	Analog Input 05*	RO	WORD	User-Defined
40067	Analog Input 06*	RO	WORD	User-Defined
40068	Analog Input 07*	RO	WORD	User-Defined
40069	<i>Reserved for Additional Input</i>	RO	WORD	
40070	<i>Reserved for Additional Input</i>	RO	WORD	
40071	<i>Reserved for Additional Input</i>	RO	WORD	
40072	<i>Reserved for Additional Input</i>	RO	WORD	
40073	<i>Reserved for Additional Input</i>	RO	WORD	
40074	<i>Reserved for Additional Input</i>	RO	WORD	
40075	<i>Reserved for Additional Input</i>	RO	WORD	
40076	<i>Reserved for Additional Input</i>	RO	WORD	
40077-40078	Digital Input Status	RO	2 WORDS	Input is high if individual bit is set. 40077 Word #1 Digital Inputs 0-15: Bit 0 Remote start contacts Bit 1 Emergency stop Bit 2 Low coolant level Bit 3 Digital Input #1 Bit 4 Digital Input #2 Bit 5 Digital Input #3 Bit 6 Digital Input #4 Bit 7 Digital Input #5 Bit 8 Digital Input #6 Bit 9 Digital Input #7 Bit 10 Digital Input #8 Bit 11 Digital Input #9 Bit 12 Digital Input #10 Bit 13 Digital Input #11 Bit 14 Digital Input #12 Bit 15 Digital Input #13

*0x7FD6 = data unavailable. 0x7FFF = data is out of range.

Register	Parameter	Access	Data Type	Range/Units
40077-40078, cont.	Digital Input Status	RO	2 WORDS	40078 Word #2 Digital Inputs 16-23 (Bits 8-15 Unused): Bit 0 Digital Input #14 Bit 1 Digital Input #15 Bit 2 Digital Input #16 Bit 3 Digital Input #17 Bit 4 Digital Input #18 Bit 5 Digital Input #19 Bit 6 Digital Input #20 Bit 7 Digital Input #21 Bit 8 Unused Bit 9 Unused Bit 10 Unused Bit 11 Unused Bit 12 Unused Bit 13 Unused Bit 14 Unused Bit 15 Unused
40079	<i>Reserved for Future Use</i>	RO	WORD	
40080	<i>Reserved for Future Use</i>	RO	WORD	
40081	<i>Reserved for Future Use</i>	RO	WORD	
40082	<i>Reserved for Future Use</i>	RO	WORD	
40083	<i>Reserved for Future Use</i>	RO	WORD	
40084	Total Number Of Starts	RO	WORD	Starts
40085	Total Run Time Hours	RO	LONG	Hrs. x 100 (LSW First)
40087	Total Run Time Loaded Hours	RO	LONG	Hrs. x 100 (LSW First)
40089	Total Run Time Unloaded Hours	RO	LONG	Hrs. x 100 (LSW First)
40091	Total Run Time kW Hours	RO	LONG	kW Hrs. (LSW First)
40093	RTSM (Run Time Since Maintenance) Total Hours	RO	LONG	Hrs. x 100 (LSW First)
40095	RTSM Loaded Hours	RO	LONG	Hrs. x 100 (LSW First)
40097	RTSM Unloaded Hours	RO	LONG	Hrs. x 100 (LSW First)
40099	RTSM kW Hours	RO	LONG	kW Hrs. (LSW First)
40101	Last Maintenance Date	RO	2 WORDS	Day Month, Year
40103	Operating Days Since Maint.	RO	WORD	Days
40104	Number Of Starts Since Maint.	RO	WORD	Starts
40105	Last Start Date	RO	2 WORDS	Day Month, Year
40107	Last Start Time	RO	WORD	Hr. Min.
40108	Last Run Length	RO	WORD	Hrs. x 100
40109	Last Run Loaded	RO	WORD	0 = Unloaded, 1 = Loaded
40110	Timed Run Time	RW	WORD	Hr. Min.
40111	Timed Run Remaining	RO	WORD	Hr. Min.
40112	Is Timed Run Active	RO	WORD	1 = True, 0 = False
40113	Current Date	RW	2 WORDS	Day Month, 2 Digit Year Day Of Week (0 = Sunday)
40115	Current Time (24 Hr. Clock)	RW	WORD	Hr. Min.
40116	Time Delay Engine Start	RW	WORD	Min. Sec.
40117	Time Delay Starting Aid	RW	WORD	Min. Sec.
40118	Time Delay Crank On	RW	WORD	Min. Sec.
40119	Time Delay Crank Pause	RW	WORD	Min. Sec.
40120	Time Delay Engine Cooldown	RW	WORD	Min. Sec.
40121	Time Delay Crank Cycles	RW	WORD	Cycles
40122	Time Delay Overvoltage	RW	WORD	Min. Sec.
40123	Time Delay Undervoltage	RW	WORD	Min. Sec.
40124	Time Delay Load Shed kW	RW	WORD	Min. Sec.
40125	Operating Mode	RW	WORD	1 = Standby, 2 = Prime Power

*0x7FD6 = data unavailable. 0x7FFF = data is out of range.

Register	Parameter	Access	Data Type	Range/Units
40126	System Voltage	RW	WORD	Volts AC
40127	System Frequency	RW	WORD	Hz
40128	System Phase	RW	WORD	1 = 3 Phase Delta, 2 = 3 Phase Wye, 3 = Single Phase
40129	kW Rating	RW	WORD	kW
40130	Load Shed Output	RW	WORD	% of kW Rating
40131	Overvoltage	RW	WORD	% of System Voltage
40132	Undervoltage	RW	WORD	% of System Voltage
40133	Overfrequency	RW	WORD	% of System Frequency
40134	Underfrequency	RW	WORD	% of System Frequency
40135	Overspeed	RW	WORD	Hz
40136	Battery Voltage	RW	WORD	Volts DC x 10
40137	Low Battery Voltage	RW	WORD	Volts DC x 10
40138	High Battery Voltage	RW	WORD	Volts DC x 10
40139	Metric Units	RW	WORD	1 = True, 0 = False
40140	NFPA 110 Defaults Enabled	RW	WORD	1 = True, 0 = False
40141	Rated Current	RO	WORD	Amps AC
40142	<i>Reserved for Future Use</i>	RO	WORD	
40143	<i>Reserved for Future Use</i>	RO	WORD	
40144	<i>Reserved for Future Use</i>	RO	WORD	
40145	<i>Reserved for Future Use</i>	RO	WORD	
40146	<i>Reserved for Future Use</i>	RO	WORD	
40147	Final Assembly Date	RO	2 WORDS	Day Month, Year
40149	Final Assembly Clock No.	RO	LONG	99999 Max (LSW First)
40151	Total Operating Days	RO	WORD	Days
40152	Model No.	RO	13 WORDS	26 Character String
40165	Spec. No.	RO	8 WORDS	16 Character String
40173	Genset Serial No.	RO	10 WORDS	20 Character String
40183	Alternator Part No.	RO	10 WORDS	20 Character String
40193	Engine Part Number	RO	10 WORDS	20 Character String
40203	Control No.	RO	LONG	(LSW First)
40205	Code Version	RO	3 WORDS	6 Character String
40208	Setup Lock	RO	WORD	1 = Locked, 0 = Unlocked
40209	Engine Model Number	RO	4 WORDS	8 Character String (ECM only)
40213	Engine Serial Number	RO	5 WORDS	10 Character String (ECM only)
40218	Unit Number	RO	5 WORDS	10 Character String (ECM only)
40223	ECM Serial Number	RO	4 WORDS	8 Character String (ECM only)
40227-40499:	Digital Inputs	RW	13 WORDS PER INPUT	For each digital input: Word #1: Enabled (1 = True, 0 = False Function Code Word #2: Inhibit Time (Min. Sec.) Word #3: Delay Time (Min. Sec.) Words #4-13: 10 words for 20-character description string. Refer to the Function Codes section in this Appendix for digital input function codes.
40227	Digital Input 01	RW	13 WORDS	
40240	Digital Input 02	RW	13 WORDS	
40253	Digital Input 03	RW	13 WORDS	
40266	Digital Input 04	RW	13 WORDS	
40279	Digital Input 05	RW	13 WORDS	
40292	Digital Input 06	RW	13 WORDS	
40305	Digital Input 07	RW	13 WORDS	
40318	Digital Input 08	RW	13 WORDS	
40331	Digital Input 09	RW	13 WORDS	
40344	Digital Input 10	RW	13 WORDS	
40357	Digital Input 11	RW	13 WORDS	
40370	Digital Input 12	RW	13 WORDS	

*0x7FD6 = data unavailable. 0x7FFF = data is out of range.

Register	Parameter	Access	Data Type	Range/Units
40383	Digital Input 13	RW	13 WORDS	For each digital input: Word #1: Enabled (1 = True, 0 = False Function Code Word #2: Inhibit Time (Min. Sec.) Word #3: Delay Time (Min. Sec.) Words #4-13: 10 words for 20-character description string. Refer to the Function Codes section in this Appendix for digital input function codes.
40396	Digital Input 14	RW	13 WORDS	
40409	Digital Input 15	RW	13 WORDS	
40422	Digital Input 16	RW	13 WORDS	
40435	Digital Input 17	RW	13 WORDS	
40448	Digital Input 18	RW	13 WORDS	
40461	Digital Input 19	RW	13 WORDS	
40474	Digital Input 20	RW	13 WORDS	
40487	Digital Input 21	RW	13 WORDS	
Note: Cannot read past end of block				
40500-40739:	Analog Inputs	RW	16 WORDS	For each analog input: Word #1: Warning/Shutdown Enable [bits 8,9] (1 = True, 0 = False) Inhibit Time (Sec.) Word #2: Warn Time (Sec) Sdwn Time (Sec.) Word #3: Lower Warn Limit Word #4: Upper Warn Limit Word #5: Lower Sdwn Limit Word #6: Upper Sdwn Limit Words #7-16: 10 words for 20-character description string
40500	Analog Input 01 (<i>ECM only</i>)	RW	16 WORDS	
40516	Analog Input 02 (<i>ECM only</i>)	RW	16 WORDS	
40532	Analog Input 03	RW	16 WORDS	
40548	Analog Input 04	RW	16 WORDS	
40564	Analog Input 05	RW	16 WORDS	
40580	Analog Input 06	RW	16 WORDS	
40596	Analog Input 07	RW	16 WORDS	
Note: Cannot read past end of block				
40612	<i>Reserved for additional analog input</i>	RO	16 WORDS	For each analog input: Word #1: Warning/Shutdown Enable [bits 8,9] (1 = True, 0 = False) Inhibit Time (Sec.) Word #2: Warn Time (Sec) Sdwn Time (Sec.) Word #3: Lower Warn Limit Word #4: Upper Warn Limit Word #5: Lower Sdwn Limit Word #6: Upper Sdwn Limit Words #7-16: 10 words for 20-character description string
40628	<i>Reserved for additional analog input</i>	RO	16 WORDS	
40644	<i>Reserved for additional analog input</i>	RO	16 WORDS	
40660	<i>Reserved for additional analog input</i>	RO	16 WORDS	
40676	<i>Reserved for additional analog input</i>	RO	16 WORDS	
40692	<i>Reserved for additional analog input</i>	RO	16 WORDS	
40708	<i>Reserved for additional analog input</i>	RO	16 WORDS	
40724	<i>Reserved for additional analog input</i>	RO	16 WORDS	
Note: Cannot read past end of block				
40740-40837:	Defined Common Faults	RW	1 WORD per DCF	For all DCFs: Selected (1 = True, 0 = False) Setpoint (Analog inputs only) Note: DCF and RDO on ECM only Note: DCF and RDO on ECM only
40740	Emergency Stop	RW	1 WORD	
40741	Overspeed	RW	1 WORD	
40742	Overcrank	RW	1 WORD	
40743	High Coolant Temperature Shutdown	RW	1 WORD	
40744	Oil Pressure Shutdown	RW	1 WORD	
40745	Low Coolant Temperature	RW	1 WORD	
40746	Low Fuel	RW	1 WORD	
40747	High Coolant Temperature Warning	RW	1 WORD	
40748	Oil Pressure Warning	RW	1 WORD	
40749	Master Not In Auto	RW	1 WORD	
40750	NFPA 110 Fault	RW	1 WORD	
40751	Low Battery Voltage	RW	1 WORD	
40752	High Battery Voltage	RW	1 WORD	
40753	Battery Charger Fault	RW	1 WORD	
40754	System Ready	RW	1 WORD	
40755	Loss of ECM Comm	RW	1 WORD	
*0x7FD6 = data unavailable. 0x7FFF = data is out of range.				

Register	Parameter	Access	Data Type	Range/Units
40756	No Oil Pressure Signal	RW	1 WORD	
40757	High Oil Temperature Shutdown	RW	1 WORD	
40758	No Coolant Temperature Signal	RW	1 WORD	
40759	Low Coolant Level	RW	1 WORD	
40760	Speed Sensor Fault	RW	1 WORD	
40761	Locked Rotor	RW	1 WORD	
40762	Master Switch Error	RW	1 WORD	
40763	Master Switch Open	RW	1 WORD	
40764	Master Switch Off	RW	1 WORD	
40765	AC Sensing Loss	RW	1 WORD	
40766	Overvoltage	RW	1 WORD	
40767	Undervoltage	RW	1 WORD	
40768	Weak Battery	RW	1 WORD	
40769	Overfrequency	RW	1 WORD	
40770	Underfrequency	RW	1 WORD	
40771	Load Shed kW Overload	RW	1 WORD	
40772	Load Shed kW Underfrequency	RW	1 WORD	
40773	Over Current	RW	1 WORD	
40774	EPS Supplying Load	RW	1 WORD	
40775	Internal Fault	RW	1 WORD	
40776	Engine Cooldown Delay	RW	1 WORD	
40777	Engine Start Delay	RW	1 WORD	
40778	Starting Aid	RW	1 WORD	
40779	Generator Running	RW	1 WORD	
40780	Air Damper Control	RW	1 WORD	
40781	Ground Fault	RW	1 WORD	
40782	EEPROM Write Failure	RW	1 WORD	
40783	Critical Overvoltage	RW	1 WORD	
40784	Alternator Protect Shutdown	RW	1 WORD	
40785	Air Damper Indicator	RW	1 WORD	
40786	Digital Input 01	RW	1 WORD	
40787	Digital Input 02	RW	1 WORD	
40788	Digital Input 03	RW	1 WORD	
40789	Digital Input 04	RW	1 WORD	
40790	Digital Input 05	RW	1 WORD	
40791	Digital Input 06	RW	1 WORD	
40792	Digital Input 07	RW	1 WORD	
40793	Digital Input 08	RW	1 WORD	
40794	Digital Input 09	RW	1 WORD	
40795	Digital Input 10	RW	1 WORD	
40796	Digital Input 11	RW	1 WORD	
40797	Digital Input 12	RW	1 WORD	
40798	Digital Input 13	RW	1 WORD	
40799	Digital Input 14	RW	1 WORD	
40800	Digital Input 15	RW	1 WORD	
40801	Digital Input 16	RW	1 WORD	
40802	Digital Input 17	RW	1 WORD	
40803	Digital Input 18	RW	1 WORD	
40804	Digital Input 19	RW	1 WORD	
40805	Digital Input 20	RW	1 WORD	
40806	Digital Input 21	RW	1 WORD	

*0x7FD6 = data unavailable. 0x7FFF = data is out of range.

Register	Parameter	Access	Data Type	Range/Units
40807	Analog Input 01	RW	1 WORD	Note: Non-zero setpoint values apply only to Analog Inputs 1-7.
40808	Analog Input 02	RW	1 WORD	
40809	Analog Input 03	RW	1 WORD	
40810	Analog Input 04	RW	1 WORD	
40811	Analog Input 05	RW	1 WORD	
40812	Analog Input 06	RW	1 WORD	
40813	Analog Input 07	RW	1 WORD	
40814	<i>Reserved for Additional Input</i>	RO	1 WORD	
40815	<i>Reserved for Additional Input</i>	RO	1 WORD	
40816	<i>Reserved for Additional Input</i>	RO	1 WORD	
40817	<i>Reserved for Additional Input</i>	RO	1 WORD	
40818	<i>Reserved for Additional Input</i>	RO	1 WORD	
40819	<i>Reserved for Additional Input</i>	RO	1 WORD	
40820	<i>Reserved for Additional Input</i>	RO	1 WORD	
40821	<i>Reserved for Additional Input</i>	RO	1 WORD	
40822 through 40837	<i>Reserved for Future Use</i>	RO		
Note: Cannot read past end of block				
40838	RDO Status - RDO1 -> RDO16	RO*	1 WORD	Output is high if individual bit is set. Bit 0 = RDO 1 <i>Software-controlled RDOs are RW.</i>
40839	RDO Status - RDO17 -> RDO31	RO*	1 WORD	Output is high if individual bit is set. Bit 0 = RDO 17 <i>Software-controlled RDOs are RW.</i>
Note: Cannot read past end of block				
40840	Relay Driver Output 01	RW	1 WORD	For RDOs: Message Code Setpoint Note: Non-zero setpoint values apply only to RDOs assigned to analog inputs. See the Message Codes section in this Appendix for message codes.
40841	Relay Driver Output 02	RW	1 WORD	
40842	Relay Driver Output 03	RW	1 WORD	
40843	Relay Driver Output 04	RW	1 WORD	
40844	Relay Driver Output 05	RW	1 WORD	
40845	Relay Driver Output 06	RW	1 WORD	
40846	Relay Driver Output 07	RW	1 WORD	
40847	Relay Driver Output 08	RW	1 WORD	
40848	Relay Driver Output 09	RW	1 WORD	
40849	Relay Driver Output 10	RW	1 WORD	
40850	Relay Driver Output 11	RW	1 WORD	
40851	Relay Driver Output 12	RW	1 WORD	
40852	Relay Driver Output 13	RW	1 WORD	
40853	Relay Driver Output 14	RW	1 WORD	
40854	Relay Driver Output 15	RW	1 WORD	
40855	Relay Driver Output 16	RW	1 WORD	
40856	Relay Driver Output 17	RW	1 WORD	
40857	Relay Driver Output 18	RW	1 WORD	
40858	Relay Driver Output 19	RW	1 WORD	
40859	Relay Driver Output 20	RW	1 WORD	
40860	Relay Driver Output 21	RW	1 WORD	
40861	Relay Driver Output 22	RW	1 WORD	
40862	Relay Driver Output 23	RW	1 WORD	
40863	Relay Driver Output 24	RW	1 WORD	
40864	Relay Driver Output 25	RW	1 WORD	
40865	Relay Driver Output 26	RW	1 WORD	
*0x7FD6 = data unavailable. 0x7FFF = data is out of range.				

Register	Parameter	Access	Data Type	Range/Units
40866	Relay Driver Output 27	RW	1 WORD	For RDOs: Message Code Setpoint Note: Non-zero setpoint values apply only to RDOs assigned to analog inputs. See the Message Codes section in this Appendix for message codes.
40867	Relay Driver Output 28	RW	1 WORD	
40868	Relay Driver Output 29	RW	1 WORD	
40869	Relay Driver Output 30	RW	1 WORD	
40870	Relay Driver Output 31	RW	1 WORD	
Note: Cannot read past end of block				
40871	Event History, Page 1 (1-10)	RO	40 WORDS	For event history: Message code Setpoint* Hr. Min. Day Month, Year * Analog Inputs only See the Message Codes section in this Appendix for message codes Note: Message code = 0xFF at end of history.
40911	Event History, Page 2 (11-20)	RO	40 WORDS	
40951	Event History, Page 3 (21-30)	RO	40 WORDS	
40991	Event History, Page 4 (31-40)	RO	40 WORDS	
41031	Event History, Page 5 (41-50)	RO	40 WORDS	
41071	Event History, Page 6 (51-60)	RO	40 WORDS	
41111	Event History, Page 7 (61-70)	RO	40 WORDS	
41151	Event History, Page 8 (71-80)	RO	40 WORDS	
41191	Event History, Page 9 (81-90)	RO	40 WORDS	
41231	Event History, Page 10 (91-100)	RO	40 WORDS	
Note: Cannot read past end of block				
41271	Designation	RW	5 WORDS	9-Character String
41276	Load	RW	10 WORDS	20-Character String
41286	Location	RW	10 WORDS	20-Character String
Note: Cannot read past end of block				
41296-41305	Reserved for Future Use	RO	WORD	
Note: Cannot read past end of block				
41306	Start Timed Run	WO	WORD	1 = Start, 0 = No Start
41307	Stop Timed Run	WO	WORD	1 = Stop, 0 = No Stop
41308	Reset Maintenance Records	WO	WORD	1 = Reset, 0 = No Reset
*0x7FD6 = data unavailable. 0x7FFF = data is out of range.				

Message Codes: Event History, Common Fault, and RDO Byte Summary

Code	Display Message
0	Emergency Stop
1	Overspeed
2	Overcrank
3	High Coolant Temperature Shutdown
4	Oil Pressure Shutdown
5	Low Coolant Temperature Note: DCF and RDO on ECM only
6	Low Fuel
7	High Coolant Temperature Warning
8	Oil Pressure Warning
9	Master Not In Auto
10	NFPA 110 Fault
11	Low Battery Voltage
12	High Battery Voltage
13	Battery Charger Fault
14	System Ready
15	Loss of ECM Comm Note: DCF and RDO on ECM only
16	No Oil Pressure Signal
17	High Oil Temperature Shutdown
18	No Coolant Temperature Signal
19	Low Coolant Level
20	Speed Sensor Fault
21	Locked Rotor
22	Master Switch Error
23	Master Switch Open
24	Master Switch Off
25	AC Sensing Loss
26	Overvoltage
27	Undervoltage
28	Weak Battery
29	Overfrequency
30	Underfrequency
31	Load Shed kW Overload
32	Load Shed kW Underfrequency
33	Over Current
34	Emergency power supply (EPS) Supplying Load
35	Internal Fault
36	Engine Cooldown Delay
37	Engine Start Delay
38	Starting Aid
39	Generator Running
40	Air Damper Control
41	Ground Fault
42	EEPROM Write Failure
43	Critical Overvoltage
44	Alternator Protect Shutdown
45	Air Damper Indicator
46	Digital Input 01
47	Digital Input 02

Code	Display Message
48	Digital Input 03
49	Digital Input 04
50	Digital Input 05
51	Digital Input 06
52	Digital Input 07
53	Digital Input 08
54	Digital Input 09
55	Digital Input 10
56	Digital Input 11
57	Digital Input 12
58	Digital Input 13
59	Digital Input 14
60	Digital Input 15
61	Digital Input 16
62	Digital Input 17
63	Digital Input 18
64	Digital Input 19
65	Digital Input 20
66	Digital Input 21
67	Analog Input 01
68	Analog Input 02
69	Analog Input 03
70	Analog Input 04
71	Analog Input 05
72	Analog Input 06
73	Analog Input 07
74-81	<i>Reserved for Future Use</i>

The following system message codes cannot be defined as common faults but can be assigned to RDOs and are referenced in the event stack and history.

Message Code	Description
82	Defined Common Fault
83	Software-Controlled RDO #1
84	Software-Controlled RDO #2
85	Software-Controlled RDO #3
86	Software-Controlled RDO #4
87-98	<i>Reserved</i>

The following system message codes cannot be defined as common faults or assigned to RDOs but can be referenced in the event stack and history.

Message Code	Description
99	Genset Parameter Warning
100	Genset S/N Mismatch Warning
101	Genset S/N Mismatch Shutdown

Function Codes: Digital Auxiliary Input

Code	Name	Notes
1	Warning	
2	Shutdown Type A	
3	Shutdown Type B	
4	Voltage Raise	
5	Voltage Lower	
6	VARPf Mode	
7	Remote Shutdown	
8	Remote Reset	
9	Air Damper	
10	Low Fuel	
11	Field Over Voltage	
12	Idle Mode	<i>ECM only</i>
13	Battle Switch	
14	Ground Fault	
15	Bat Chgr Fault	
16	High Oil Temperature	
17	Low Coolant Lvl	
18	Low Coolant Temperature	<i>ECM only. Not user-assignable.</i>

TP-6113 9/14h

© 2001, 2002, 2004, 2006, 2007, 2010, 2011, 2014 by Kohler Co. All rights reserved.

KOHLER[®] Power Systems

KOHLER CO. Kohler, Wisconsin 53044
Phone 920-457-4441, Fax 920-459-1646
For the nearest sales/service outlet in the
US and Canada, phone 1-800-544-2444
KOHLERPower.com

Kohler Power Systems
Asia Pacific Headquarters
7 Jurong Pier Road
Singapore 619159
Phone (65) 6264-6422, Fax (65) 6264-6455